

# 4" PPF-P Pilot-Operated Pressure Powered Pump™

Operating Pressure Range 25 to 150 psi (1.7 to 10.3 bar)

The 4" PPF-P incorporates a spring-loaded, float-operated mechanism to activate a piloted double valve arrangement. This will alternatively pressurize and vent the pump body with motive gas, usually steam, to achieve pumping. The internal mechanism serves only to operate the pilot valve. The pilot sends and relieves a motive gas signal to the main valve assembly to achieve the desired pumping sequence as outlined below.

### How the 4" PPF-P Pump Operates (Fig.1)

1. In the normal position before startup, the float (1) is at its lowest position with pilot signal relieved, motive pressure inlet valve (2) is closed, and the exhaust valve (3) is open.
2. When liquid flows by gravity through the inlet check valve (4) into the pump body, the float (1) rises, increasing tension in the springs (6) until the upper tripping position is reached. The stored spring energy is instantaneously released, causing the push rod (5) and actuator disc (7) to snap upward against the pilot valve (8), thus opening the pilot valve.

3. Fig. 1A - The pilot valve signal pressurizes the intermediate case diaphragms (9), the diaphragms are deflected simultaneously, causing the inlet valve to open and the exhaust valve to close. Motive gas is admitted to the pump body by way of the connecting hose (10) causing it to pressurize and discharge the liquid through the outlet check valve (11).
4. Fig. 1 - As the liquid level in the pump body decreases, the float falls, increasing tension on the springs (6) until the lower trip position is reached. The stored spring energy is again released, causing the push rod to snap in the downward position, allowing the pilot valve (8) stem to fall closed.
5. Fig. 1B - With the pilot valve in the "closed position", the motive supply signal is shut off to the intermediate case (9), relieving pressure in the intermediate case to the exhaust side piping. The diaphragms simultaneously assume the relaxed position, causing the inlet valve (2) to close and the exhaust valve (3) to open. The pump body then vents excess pressure.
6. Liquid will again flow through the inlet check valve (4) to fill the pump body, repeating the same cycle.

Fig. 1

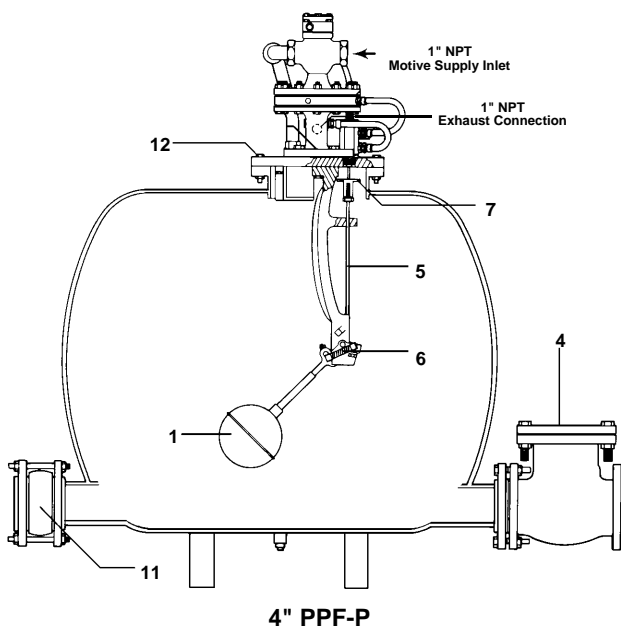

Fig. 1A

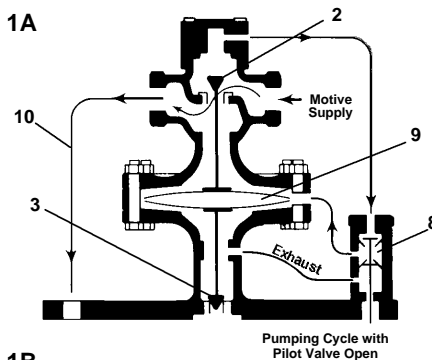
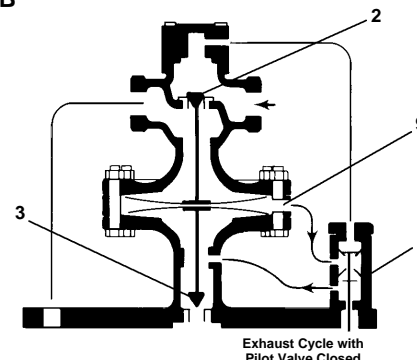

Fig. 1B



# Installation — Vented Systems (Fig. 2)

**Caution:**

Before installation or any maintenance is performed, ensure that all steam, air or gas lines are closed to prevent personnel injury.

1. Install the pump physically below the receiver to be drained. Pump should be installed with the recommended filling head (the vertical distance between the top of the pump body and the bottom of the receiver) as shown in Fig. 2.

**Recommended Filling Head is 24" for rated capacity.** For other filling head variations, see Capacity Table on TIS 5.202.

2. To collect condensate from multiple sources and prevent equipment flooding during the pump discharge stroke, a vented receiver should be installed in a horizontal plane ahead of the pump as shown in Fig. 2. For proper vented receiver sizing, refer to "Vented Receiver" tables shown below. All inlet line fittings between pump and receiver must be fully ported.

**Vented Receivers**

Sufficient reservoir volume is needed above the filling head level to accept the condensate reaching the receiver during the pump discharge stroke. More importantly, the receiver must be sized to allow sufficient area for complete flash steam separation from the condensate. By sizing the receiver based on the amount of flash steam present, as shown below, there will be sufficient volume for condensate storage and sufficient area for flash steam separation. The receiver can be a length of large diameter pipe or a tank.

Flash Steam Up to	Receiver Diameter	Receiver Length	Vent Line Diameter
1,000 lb/h	16"	60"	6"
2,000 lb/h	20"	60"	8"
3,000 lb/h	24"	60"	10"
4,000 lb/h	26"	60"	10"
5,000 lb/h	28"	60"	12"
6,000 lb/h	30"	72"	14"
7,000 lb/h	32"	72"	16"
8,000 lb/h	36"	72"	16"

If desired, receiver overflow piping can be installed as shown in Fig. 2 and piped to a suitable drain. The piping must form a loop type water seal at least 12" deep immediately after the receiver.

3. Connect the vented receiver to the inlet check valve on the pump. Connect the discharge to the return main or other installation point. For best performance, horizontal piping runs immediately ahead of the inlet check valve and after the discharge check valve should be kept to a minimum.

**Note:**

To achieve rated capacity, pump must be installed with check valves as supplied by Spirax Sarco, Inc.

4. Connect the operating medium (steam, air or gas) supply to the pump motive supply inlet connection in the inlet valve. Supply piping should have a strainer and steam trap (steam service) or drain trap (air or gas service) installed upstream of the supply inlet. The steam trap discharge should be piped into the receiver ahead of the pump. The drain trap discharge should be piped to drain, due to likelihood of oil presence.

**Note:**

When available motive pressure exceeds 150 psi, a Spirax Sarco pressure reducing valve is required to reduce pressure to the pump. The PRV outlet piping should be oversized and the valve located as far from the pump as possible. For best operation, motive pressure should be reduced to the minimum required to overcome pump back pressure and achieve the desired capacity. A safety relief valve should be installed in the motive supply piping.

5. Pump exhaust line should be piped, unrestricted, from the exhaust valve connection to atmosphere. Piping should be vertical, whenever possible. Any horizontal piping necessary must be pitched so that it is self-draining to the pump or the receiver.

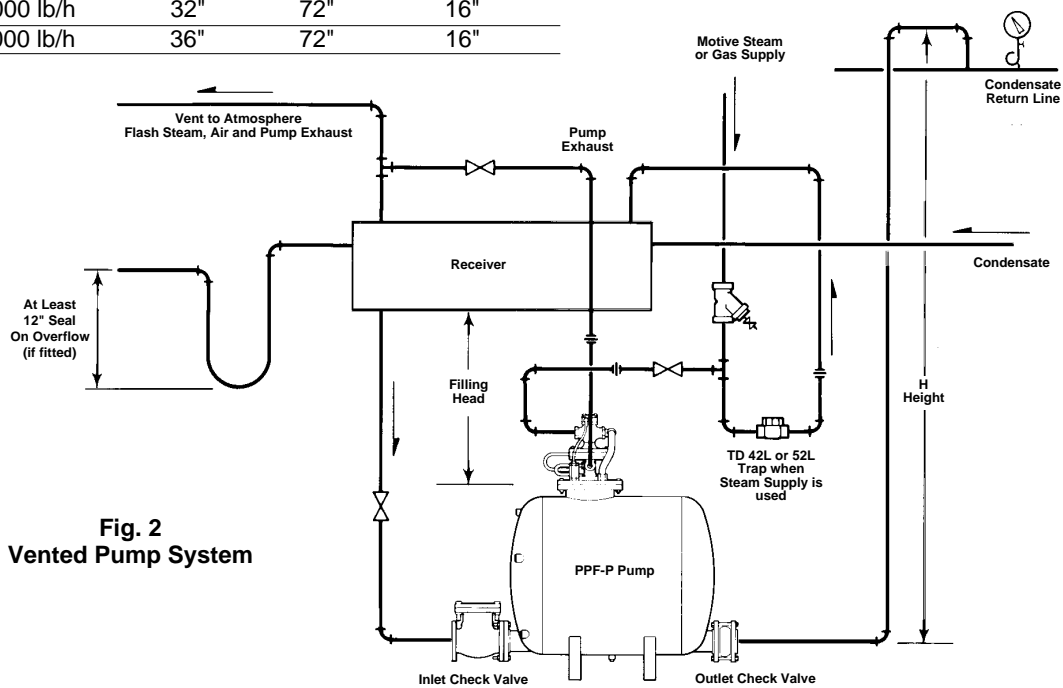

**Fig. 2**  
**Vented Pump System**

## Installation — Closed Loop Systems (Figs. 3 or 4)

In closed loop systems, the pump is used to drain equipment with steam supply modulated by a control valve. Here the pump and equipment pressures are equalized for filling by piping the pump exhaust line back to the steam space being drained.

### Caution:

Before installation or any maintenance is performed, ensure that all steam lines are closed to prevent personnel injury.

1. Install the pump and reservoir physically below the equipment to be drained. Pump should be installed with the recommended filling head (the vertical distance between the top of the pump body and the bottom of the reservoir) as shown in Fig. 3.

### Recommended Filling Head is 24" for rated capacity.

For other filling head variations, see Capacity Table on TIS 5.202.

2. To prevent equipment flooding during the pump discharge stroke, a reservoir should be installed in a horizontal plane ahead of the pump as shown in Fig. 3. For minimum reservoir sizing, refer to "Inlet Reservoir Piping" table shown below. All inlet pipe fittings between pump and reservoir must be fully ported.

### Inlet Reservoir Piping

Sufficient reservoir volume is needed above the filling head level to accept condensate reaching the pump during discharge stroke. The reservoir can be a length of large diameter pipe or a tank.

Liquid Load lbs/h.	Pipe Size			
	12"	16"	20"	24"
10,000	5'	3'	2'	—
20,000	10'	7'	4'	—
30,000	—	9'	6'	4'
40,000	—	12'	7.5'	6'
50,000	—	—	9'	6'

3. Connect the reservoir to the inlet check valve on the pump. Connect the discharge check valve to the return main or other installation point. For best performance,

horizontal piping runs immediately ahead of the inlet check valve and after the discharge check valve should be kept to a minimum.

### Note:

To achieve rated capacity, pump must be installed with check valves as supplied by Spirax Sarco, Inc.

4. Connect the operating medium (steam only) supply to the pump motive supply inlet connection in the inlet valve. Supply piping should have a strainer and steam trap installed upstream of the supply inlet. The steam trap discharge should be piped into the reservoir ahead of the pump.

### Note:

When available motive pressure exceeds 150 psi, a Spirax Sarco pressure reducing valve is required to reduce pressure to the pump. The PRV outlet piping should be oversized and the valve located as far from the pump as possible. For best operation, motive pressure should be reduced to the minimum required to overcome pump back pressure and achieve the desired capacity. A safety relief valve should be installed in the motive steam piping.

5. Exhaust line must be piped, unrestricted, to the steam space being drained. The exhaust line can be connected to the inlet pipe between the control valve and equipment, directly into the equipment, or into the top of the reservoir pipe depending on the pressure drop sensed across the heat exchange equipment. The pump exhaust must be equalized to the lowest possible pressure location to ensure gravity drainage to the pump. A thermostatic air vent should be installed at the highest point of the exhaust line to vent all non-condensibles during startup. Any horizontal runs in exhaust line should be pitched so that the line is self-draining.
6. If, at any time, the equipment supply pressure can exceed the back pressure on the pump, a properly sized float and thermostatic trap must be installed between the pump and discharge check valve as shown in Fig. 4 to prevent steam "blow-through."

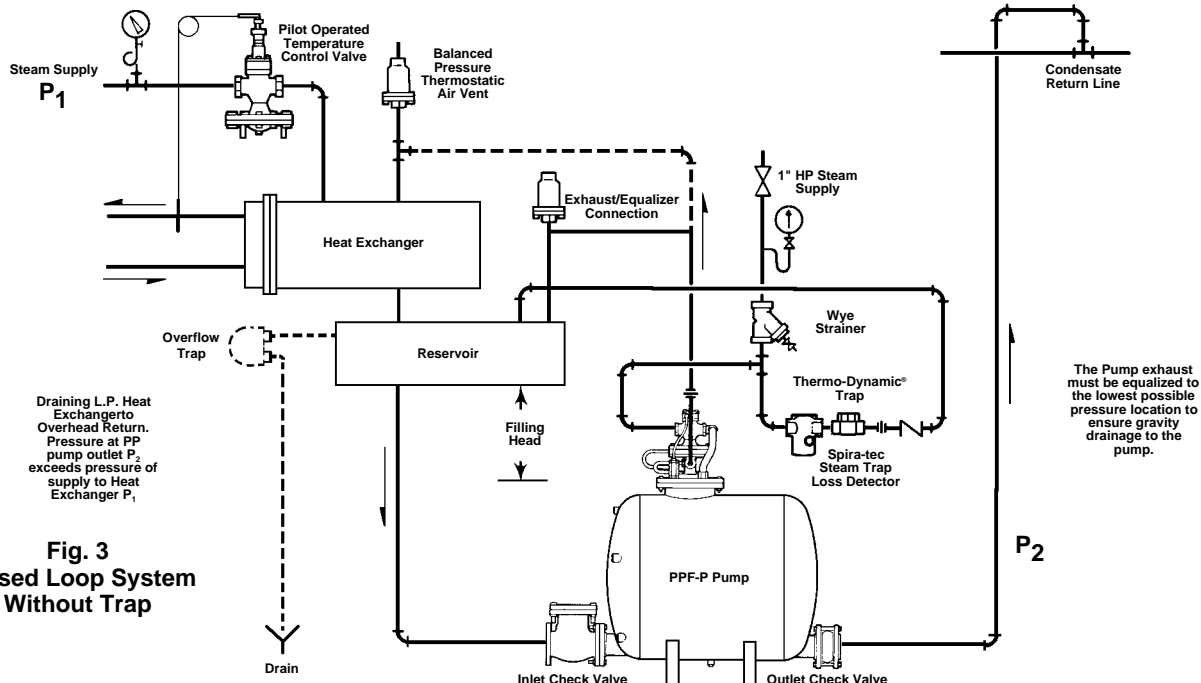
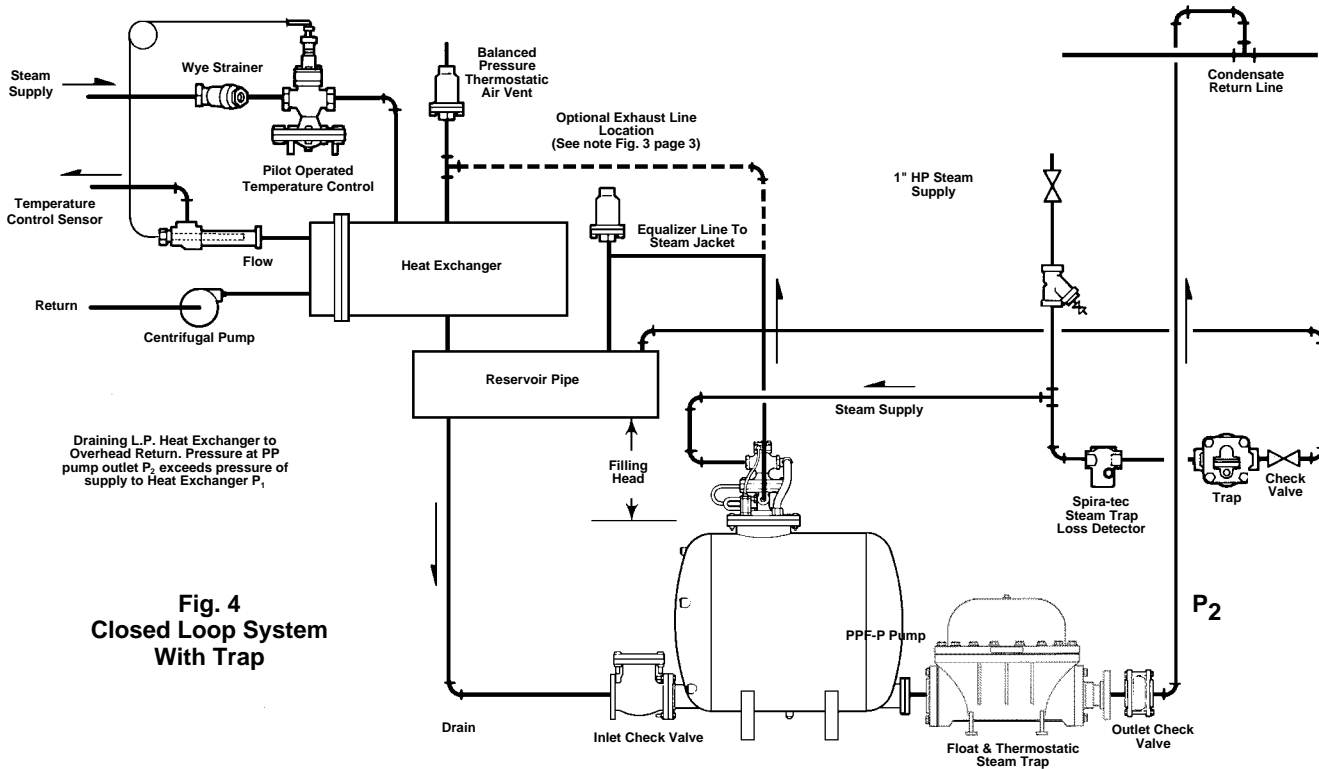

Fig. 3  
Closed Loop System  
Without Trap



**Fig. 4**  
**Closed Loop System**  
**With Trap**

## Installation—Multiple Pressure-Powered Pumps™

When multiple Pressure-Powered Pumps™ are connected to a single condensate source, momentary pressure increase in an existing return line can be prevented by piping them so that the occurrence of simultaneous discharge is minimized. Follow the hookup which applies to your multiple pump applications, either ...

- Figs. 5 & 6 High loads require use of multiple pumps for capacity and “out of phase” discharge is desired. or ...
- Fig. 7 A second pump is provided primarily for “standby or peak load” operation.

### Hookups for Staging Pump Operation

Preferred hookup where enough filling head is available is shown in Fig. 5 The primary (P1) sits at grade level and all additional pumps (P2, P3, etc.) are elevated to change the “trip level” at which each will discharge. The change in elevation between successive pumps should be approximately 6" to 12". To obtain rated pump capacity, the filling head above the highest pump must equal or exceed the height specified on TIS 5.202.

Fig. 6 is an alternate hookup for use when filling head is restricted, preventing changes in pump elevation. Here the primary pump (P1) is connected closest to the supply from reservoir with higher and longer piping to each additional pump (P2, P3, etc.) Locate the higher takeoff piping above the center of the primary pump (P1) but below the receiver/reservoir. In operation, the filling head on each pump is the same but the fill rate changes enough that the pump discharge times are staggered.

### “Standby” Duplex Pump Hookup

Locating the takeoff piping to the inlet of a second pump above the filling head required by the primary pump as shown in Fig. 7 makes it fill and discharge primarily when the main pump cannot handle the load. The takeoff may be from the reservoir (but below the maximum water level that can be tolerated), or lower on the supply pipe where it will operate a little more often. With its inlet piping fitted in this area, the second pump will operate primarily on peak loads or as a “standby” in the event of primary pump failure.

### Startup Procedure (All Hookups)

1. Slowly open supply (steam, air or gas) to provide pressure at the pump inlet valve. Motive supply MUST be open PRIOR TO opening condensate inlet valve. Check that trap/drain on motive line is operational.
2. Open gate valve in the pump condensate inlet and discharge lines and any valves on exhaust line.
3. Open valve(s) ahead of unit allowing condensate to enter the receiver/reservoir and fill the pump body. Pump will discharge when full.
4. Observe operation for any abnormalities. Pump(s) should cycle periodically with an audible exhaust at the end of the pumping cycle. If any irregularities are observed, recheck installation instructions for proper hookup and refer to “Troubleshooting Checklist”. Consult factory if necessary.
5. If overflow piping has been provided, check that a water seal has been established to prevent any steam from being vented during normal operation. Prime overflow piping if necessary.

**Fig. 5**  
**Staging Discharge Time**  
**by Elevating Pump Body**

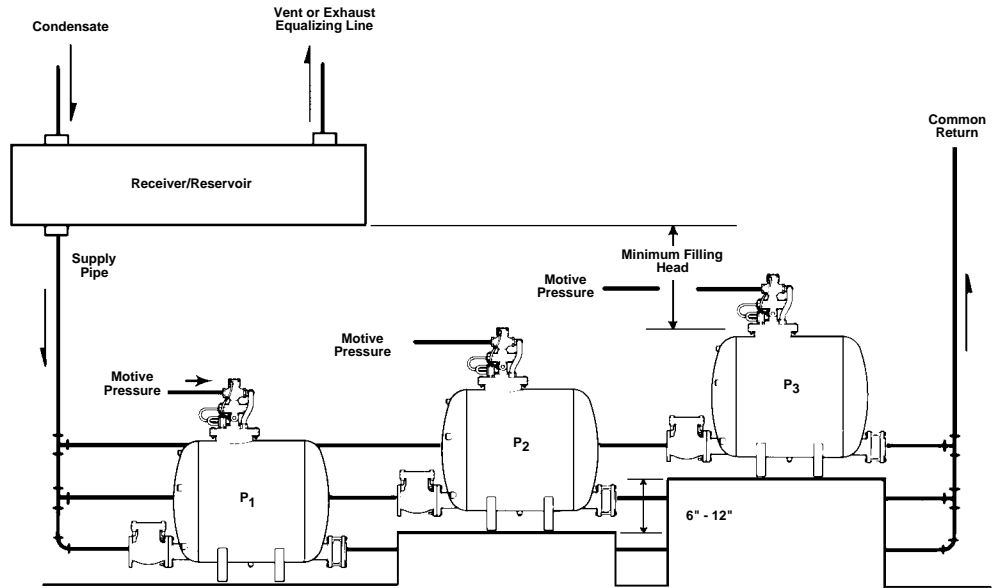

**Fig. 6**  
**Alternate Hookup to Stage**  
**Pump Discharge Time**

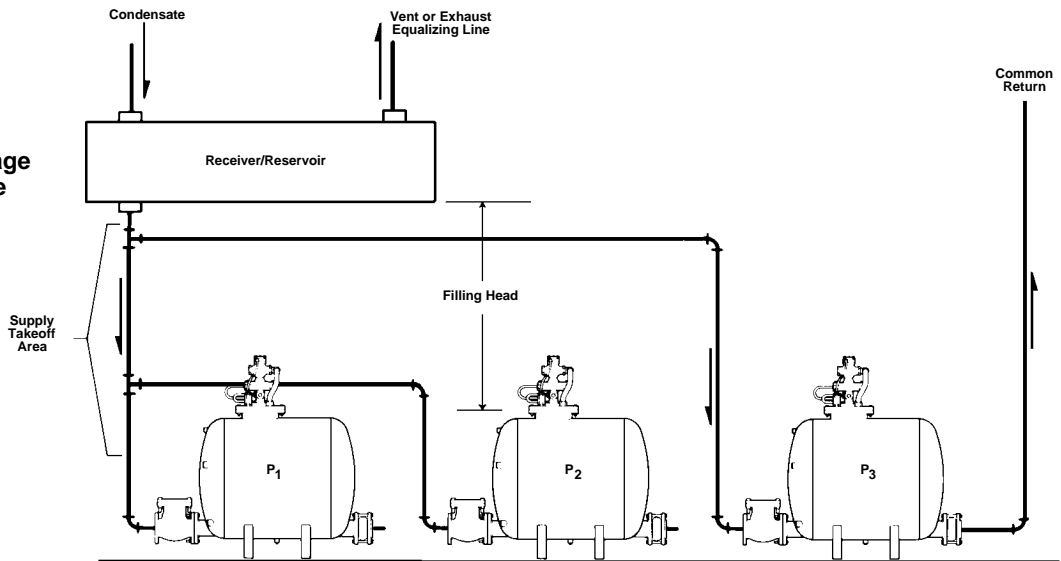

**Fig. 7**  
**Duplex Pump for Standby**  
**or Peak Load Operation**

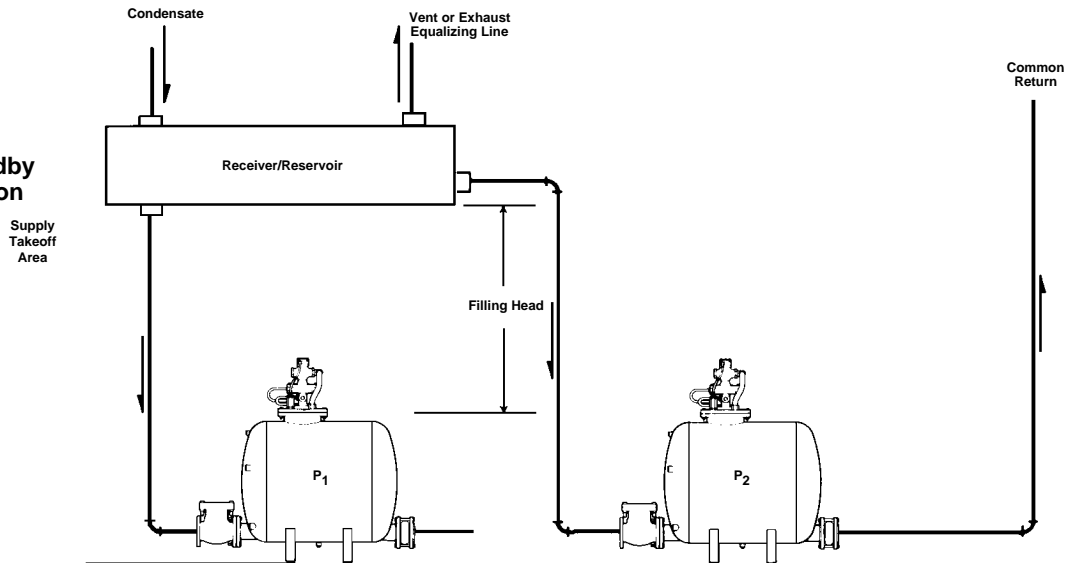

# Maintenance: Inspection & Repairs

## General Arrangement

The 4" PPF-P consists of three sub-assemblies. These include the main valve, the pilot valve and the float mechanism assembly. The main valve contains both the inlet and exhaust valves and is attached to the top of the cover by means of four (4) bolts. Likewise, the pilot valve is threaded into the top of the cover and secured by a Tru-Seal® fitting. The float mechanism assembly, located within the pump body, is fastened to the cover by three (3) bolts. Inspection and repair instructions for each assembly are presented below.

## CAUTION:

*Before removing or disconnecting any assembly for inspection or repair, be sure that the pump is completely isolated and all components are relieved of any internal pressure. Motive supply, exhaust/equalizer, condensate inlet, and discharge lines should all be closed prior to performing any work on the pump. Maintenance and repair should only be performed by qualified personnel familiar with proper safety procedures for working with steam systems.*

## Main Valve Assembly (Figs. 8 & 9)

After assuring that the motive supply line has been isolated and internal pressure relieved, remove the main assembly as follows (See Fig. 8):

1. Break motive supply connection.
2. Disconnect the 1-1/2" dia. body supply hose (1) by detaching the compression swivel at the pilot 90° adapter.
3. Disconnect the three pilot signal hoses (2a, 2b, 2c) by detaching the swivel connectors at the pilot.
4. Remove four flange bolts (3).

### I. INLET VALVE HEAD AND SEAT INSPECTION & REPLACEMENT (SEE FIG.9)

1. Remove cover (1) including cap, screen (2) and spring (3).
2. Lift out valve head (4) and visually inspect seating surface of head and seat. Replace if either are worn or wire drawn.

**Note:** Head and seat should always be replaced as a set. New head and seat set should be lapped with fine grinding compound to assure tightest possible seal.

### II. EXHAUST VALVE HEAD, SEAT & STEM REPLACEMENT

Notes:a)Prior to disassembly mark the upper diaphragm case (5), the intermediate case (6), and the lower diaphragm case (14) so that proper hose orientation can be achieved upon reassembly.

b) Exhaust head (12) is fixed to the stem by a pin. Consequently, the diaphragm plate (8) must first be removed in order to remove the head and stem sub-assembly.

1. Remove bolts (13), upper diaphragm case (5), intermediate case (6) and exhaust valve diaphragm (7) to expose the exhaust valve diaphragm plate (8).
2. Remove diaphragm plate adjustment cover (16) to expose adjustment cavity (9) and jam nut. Loosen and remove jam nut. Exhaust stem end is slotted to accept screwdriver to hold stem while removing nut. Remove threaded diaphragm plate (8) and exhaust valve return spring (10) so that exhaust head is free to be withdrawn in the opposite direction.
3. Remove exhaust valve seat (11) and withdraw stem and head (12) assembly through seat threads.

4. Install new exhaust head and stem assembly (12). Then install new exhaust seat and seat gasket (11).
5. Re-install exhaust valve return spring (10) and, while pushing spring down, thread diaphragm plate (8) onto stem.
6. Adjust diaphragm plate so that with exhaust head on seat, a minimal clearance (approx. 1/32") exists between plate and lower diaphragm case (14). This is accomplished by turning down the Diaphragm Plate (8) until it touches the lower Diaphragm case (14) and then backing it out 1/2 turn. Install and lock jam nut on stem to maintain this setting. Re-install adjustment cavity cover. See note (Check & Cure 6b) trouble shooting check list for reinstallation of cover (16). Be sure that any sharp edges are removed to prevent diaphragm damage.
7. Install exhaust valve 2-ply diaphragms (7). Align lower diaphragm case (14) with intermediate case (6) and upper diaphragm case (5) as marked in note a) to original orientation and tighten flange bolts (13).

### III. DIAPHRAGM REPLACEMENT

Notes:a)Prior to disassembly mark the upper diaphragm case (5), the intermediate case (6) and the lower diaphragm case (14) so that proper hose orientation can be achieved upon reassembly.

b) Each diaphragm set is 2-ply. A total of four diaphragms are used.

1. Remove bolts (13) upper diaphragm case (5) and intermediate case (6), to expose exhaust and inlet valve diaphragms (2-ply) sets (7) and (15).
2. While disassembled, press down on both diaphragm plates to be certain they move freely.
3. Inspect and/or replace exhaust valve diaphragm set (7) and re-install intermediate case (6) in proper orientation.
4. Inspect and/or replace inlet valve diaphragm set (15) and re-install inlet valve in proper orientation.
5. Replace all flange bolts (13) and re-torque in an alternating pattern.

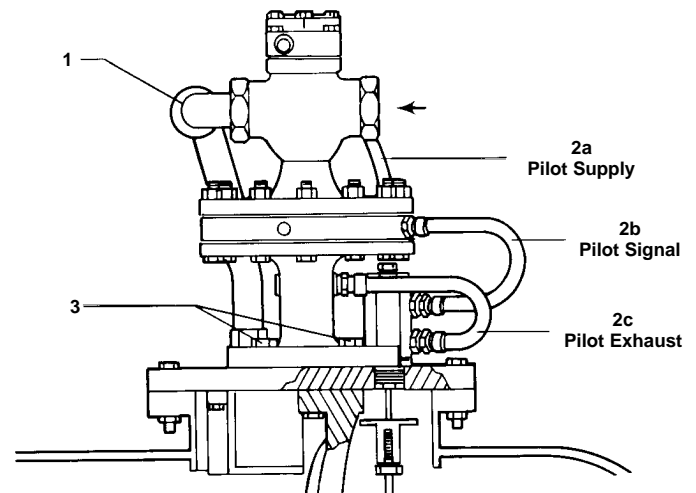

**Fig. 8**  
**4" PPF-P Main Valve Assembly and Connections**

Fig. 9  
4" PPF-P Main Valve  
Internal Components

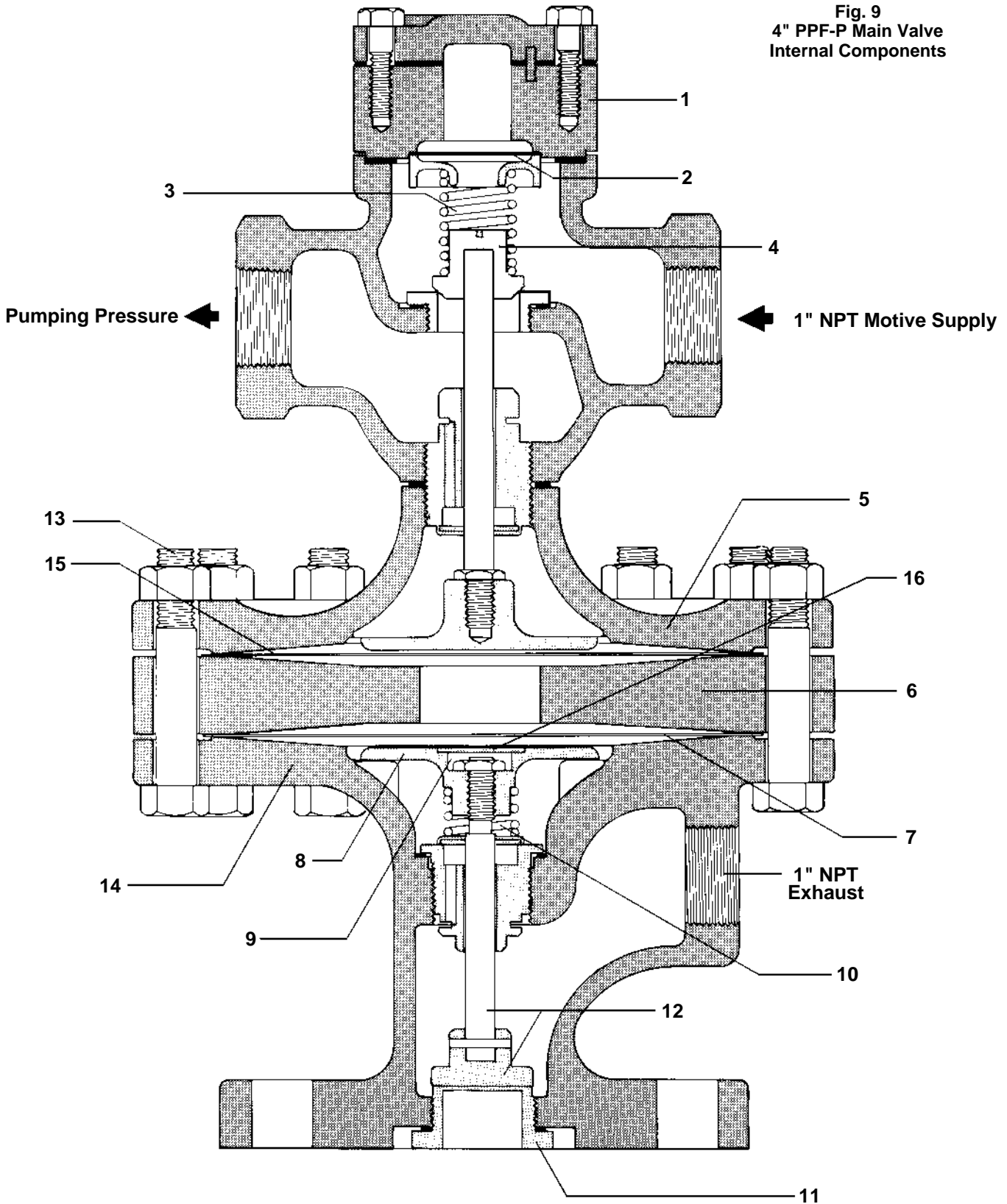

## Pilot Valve Assembly (See Fig. 10)

Note: Operation of the pump is affected by the position of the pilot stem. Consequently, when removing pilot body from the cover, a reference dimension must be taken to assure that the same depth of engagement is maintained upon reassembly or installation of a new pilot. This dimension can be measured from the top of the pilot to the cover surface or can be noted by counting turns of the pilot body upon removal.

### I. DISASSEMBLY AND INSPECTION

1. Take and record reference dimension of pilot body engagement into the cover as noted above.
2. After isolating steam supply and relieving internal pressure, remove all hoses noting proper connection locations.
3. Loosen Tru-Seal® fitting (1) and remove pilot assembly from cover.
4. Remove pilot cap (2), exposing pilot valve cartridge (3 & 4).
5. Loosen packing gland jam nut (13) and gland stud (11). Next, remove integral head and seat cartridge (3 & 4) by lightly tapping on the end of the exposed stem (5).
6. Inspect and clean head and seat seating surfaces. If either are worn or wire drawn, replacement is necessary. Stem must be clean and smooth.

### II. INSTALLATION OF PILOT VALVE CARTRIDGE

1. Replace cartridge gaskets (6 & 7).
2. Align stem into packing gland (10) and insert cartridge tight against the gaskets.
3. Install new cap gasket (8) and re-install cap (2). Cap (2) should be torqued to *100 ft/lbs. minimum* to properly seat all gaskets.
4. **IMPORTANT:** Packing nut adjustment.  
Gland stud (11) need only be finger tight once stem packing (9) has been set. Stem must move freely and have minimal resistance to motion. **DO NOT OVERTIGHTEN!!!** When new packing is installed, use two complete turns of 3/32" dia. Chesteron PTFE. Tighten gland stud (11) to finger tight plus 1/2 turn. Then back stud off 1/4 turn and lock jam nut (13). Manually move stem (5) back and forth repeatedly to assure smooth motion with minimal resistance before re-installing pilot valve assembly on cover.

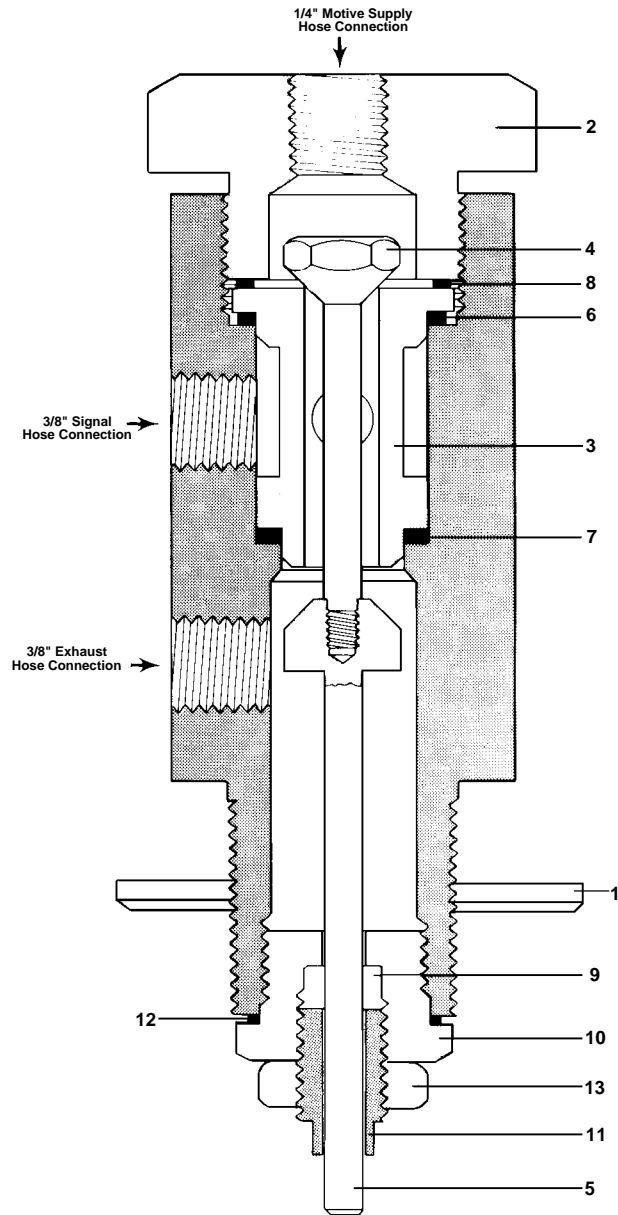

Fig. 10  
Pilot Valve Assembly

## Float Mechanism Assembly (See Fig. 1)

Note: Other than adjustments outlined below, mechanism calibrations are factory set and tested and should not be altered without consulting the factory.

1. After assuring that the pump has been isolated and all internal pressure relieved, break the motive supply and exhaust/equalizer piping connections. Remove cover bolts (12) and lift the cover and mechanism assembly from the body, noting the cover orientation.
2. Visually inspect the mechanism to verify that it is free of excessive dirt and scale and moves freely.
3. Visually check springs (6). If defective, remove retaining clips and slide springs from pins. Replace with new springs (if necessary) and install retaining clips.

4. With springs in place, raise float (1) until just prior to tripping point (springs at maximum extension). Measure the centerline to centerline distance between spring pins. A distance of 3-1/32" or less indicates excessive mechanism wear which may limit performance and lead to binding or spring breakage. If excessive mechanism wear is noted, the mechanism should be rebuilt and recalibrated. (Rebuild Kit, Stk # 66951)
5. Before re-assembly, check actuator disc (7) to pilot stem clearance setting. With float in the down position, a gap of .120" ± 0.005" should exist. Readjust actuator disc (7) as necessary to reach this setting and lock with jam nut and lockwasher. Be careful not to damage float mechanism when inserting into pump body. Align the cover correctly before tightening cover bolts (12).



## 4" PPF-P Pump Troubleshooting Checklist

If a correctly sized pump does not operate properly an incorrect hookup is suspect in new installations. For existing installations when the pump operates occasionally or not at all, the cause is often a change in system supply or back pressure conditions beyond the original design parameters. With the system conditions and problem symptoms determined, check the following and correct as necessary.

### Caution:

*Installation and troubleshooting should be performed by qualified service personnel. Before breaking any connections of the pump or piping system, every effort should be made to assure that internal pressure has been relieved and that the motive supply line is shut off to prevent inadvertent discharge of the pump. When breaking any connection, piping/bolts should be removed slowly so that if the line is under pressure, this fact will be apparent before completely removing the pump or component. Always relieve pressure before breaking any joint.*

## 4" PPF-P Pressure Powered Pump™ Troubleshooting Checklist

Symptom	Cause	Check and Cure
1. Pump fails to operate on startup.	1. a) Motive supply closed or blocked.	1. a) Slowly open valve(s) to supply motive pressure to pump. Discharge of pump contents will take considerable time if pump body is completely flooded. Initial pump discharge time can be shortened by manually draining pump prior to opening steam supply.
	b) Condensate inlet line closed.	b) Open all valves to allow condensate to reach pump.
	c) Condensate discharge line closed.	c) Open all valves to allow free discharge from pump to destination.
	d) Motive pressure insufficient to overcome backpressure.	d) Check motive pressure and static backpressure. Adjust motive pressure to 15-20 psi higher than static backpressure at discharge check valve.
	e) Pump air-locked.	e) On vented system, assure that vent line is unrestricted to atmosphere and self-draining to the pump or receiver. On a closed system, isolate the pump from the pressurized space being drained. (Exhaust/Equalizer line closed.) Break exhaust connection at pump cover. Keep personnel clear of exhaust connection. If pump begins to cycle, air locking has occurred. Recheck that exhaust/equalizer is in accordance with installation instructions. Install a thermostatic air vent at a high point in the exhaust line. Assure that the equalizer line is self-draining.
2. Supply line/equipment flooded, but pump appears to cycle normally (periodic audible exhaust observed).	2. a) Pump undersized	2. a) Verify rated capacity per TIS 5.202 capacity table. Install additional pump as required.
	b) Insufficient filling head.	b) Verify required filling head per TIS 5.202. Lower pump to achieve required filling head.

Symptom	Cause	Check and Cure
2. <i>continued from previous page</i>	<p>c) Insufficient motive pressure to achieve rated capacity.</p> <p>d) Restriction in condensate inlet line.</p> <p>e) Inlet check valve stuck open.</p> <p>f) Restriction in exhaust/equalization line.</p>	<p>c) Check motive pressure setting and maximum backpressure during operation. Compare to capacity table of TIS 5.202. Increase motive pressure as required to meet load conditions.</p> <p>d) Verify that fully ported fittings are used. Blowdown the strainer, if fitted. Check that all valves are fully open.</p> <p>e) Isolate inlet check valve and relieve line pressure. Remove cap and visually inspect head, seat and stem. Clean seating surfaces and reinstall or replace, if necessary.</p> <p>f) Assure that exhaust/equalizer line is unrestricted and self draining with no water sealed portions. (See 1e)</p>
3. Supply line/equipment flooded and pump has stopped cycling.	<p>3. a) Exhaust/Equalizer restricted causing vapor lock. (Vented or closed loop)</p> <p>b) Inlet check valve stuck closed.</p> <p>c) Discharge line closed or blocked.</p> <p>d) Discharge check valve stuck closed.</p> <p>e) Insufficient motive pressure.</p> <p>f) Float mechanism faults.  i) Broken springs  ii) Ruptured float  iii) Mechanism binding</p>	<p>3. a) Assure that exhaust/equalizer line is unrestricted and self-draining. On closed loop systems, be sure that air vent is operational. (See 1e)</p> <p>b) Isolate pump and check valve. Remove cap and visually inspect head and seat. Clean seating surfaces, check movement, and reinstall or replace, if necessary.</p> <p>c) Check motive pressure and static backpressure (at pump discharge). If equal, a closed or blocked discharge line is suspected. Check all valves downstream of pump to assure an unobstructed discharge.</p> <p>d) After checking per 3c) above, isolate discharge check valve and relieve line pressure. Disassemble and visually inspect head and seat area. Clean seating surfaces, check movement and reinstall or replace, if necessary.</p> <p>e) If motive pressure is below static backpressure, increase motive pressure setting to 15-20 psig above static backpressure. Do not exceed rated pressure limits of the pump.</p> <p>f) With motive supply and exhaust/equalizer line (closed loop only) closed, fit pressure gauge to 3/8" NPT plugged connection in intermediate case. CAUTION: HOT CONDENSATE MAY BE PRESENT WHEN REMOVING 3/8" PIPE PLUG. Slowly open motive steam supply and observe if intermediate case is pressurized. If a pressure signal in excess of 15 psig is noted, a main valve failure is indicated. See 3h) below. If no pressure signal is observed, a mechanism or pilot valve fault is indicated. Completely isolate pump and remove cover/mechanism assembly from pump body. Examine springs and float for obvious defects. Stroke mechanism and check for any source of binding or increased friction. Repair and/or replace all defects noted.</p>

Symptom	Cause	Check and Cure
3. <i>continued from previous page</i>	<p>g) Pilot valve fault.</p> <p>h) Main valve fault.</p>	<p>g) After determining possible pilot valve failure as outlined in 3f) above, manually move pilot valve stem back and forth and check for binding. If no stem binding is noted, remove pilot valve assembly from cover. Disassemble and visually inspect seating surfaces for wear or foreign matter. Clean or replace parts in accordance with instructions in "Maintenance: Inspection &amp; Repairs" section of this manual.</p> <p>h) After determining possible main valve failure as outlined in 3f) above, remove main valve assembly from cover. Disassemble and inspect per instructions in "Maintenance: Inspection &amp; Repairs" section of this manual. Check that inlet valve and exhaust valve stems move freely, diaphragms are free of defects, inlet valve and exhaust valve seating surfaces are clean and free of foreign matter. Clean and repair/replace as necessary.</p>
4. Chattering or banging in return main after pump discharges.	<p>4. a) Vacuum created at pump outlet after discharge because of acceleration/ deceleration of large water slug in return main (usually results from long horizontal run with multiple rises and drops.)</p> <p>b) Steam "blow through" into condensate return line.</p>	<p>4. a) Install a vacuum breaker at the top of the lift (at high point in return line). For pressurized return systems, an air eliminator may be required downstream of the vacuum breaker.</p> <p>b) Check condensate inlet pressure and static backpressure at the pump discharge. If inlet pressure equals or exceeds static backpressure, a "blow through" problem is suspected. On vented systems, check for leaking traps discharging into condensate inlet line which would increase inlet line pressure. Replace any faulty traps. On closed loop systems, if condensate inlet pressure can exceed static backpressure under normal operation (i.e. either through high equipment operation pressure via a modulating control valve or significant decrease in static return main pressure), a pump/trap combination is required. The steam trap will prevent passage of steam into the return main and allow the pump to discharge normally when condensate is present. (See Fig. 4)</p>
5. Vent line discharging excessive flash steam during fill cycle (vented installations only).	<p>5. a) Faulty steam traps discharging live steam into condensate inlet line. (See also 4b, "Steam Blow-through.")</p> <p>b) Excessive flash steam being vented through pump.</p> <p>c) Main valve assembly stuck or worn.</p>	<p>5. a) Check for leaking traps discharging into condensate return. Repair or replace faulty traps. (See also 4b, "Steam Blow-through.")</p> <p>b) Vent receiver ahead of pump.</p> <p>c) See 3h) above.</p>

Symptom	Cause	Check and Cure
<p>6. Vent line discharging steam during pumping/discharge cycle.</p>	<p>a) Pilot valve assembly not properly seating in discharge position.</p> <p>b) Exhaust valve diaphragm cracked or torn.</p>	<p>a) Check mechanism calibration setting of actuator disc to pilot stem end. With the float in the down position, clearance should be <math>0.120" \pm 0.005"</math>. Readjust as necessary by loosening actuator disc jam nut and repositioning disc. Lock in place with jam nut.</p> <p>b) Follow maintenance procedure for "Main Valve Assembly, III. Diaphragm Replacement" on page 6, for valve disassembly. Visually inspect diaphragms for cracks, tears, or yielding. Inspect diaphragm plate adjustment cover disc (item #16, page 7) to assure that it is firmly staked in position. On models built on or before October 1992, discs were not staked to the diaphragm plate. For these units, remove disc and file a small flat on the edge approximately 1/16" in depth. Reinstall, and using a centerpunch, stake to diaphragm plate in four places. File and sand staked areas as necessary to remove sharp edges which may damage diaphragm. Install new diaphragm set in accordance with instructions on page 6.</p>

Spirax Sarco Applications Engineering Department

Toll Free at:  
1-800-833-3246



SPIRAX SARCO, INC. • 1150 NORTHPOINT BLVD. • BLYTHEWOOD, SC 29016  
PHONE 803-714-2000 • FAX 803-714-2200