



## INSTALLATION & MAINTENANCE INSTRUCTIONS

IM-2-323-US

April 2015

# Mod.2000 Self Drainage Unit for Float & Thermostatic Trap

### Description

The drainage device is to be used on the bottom drain connection on F&T steam traps or drain traps in outdoor installations where freezing may occur. When the pressure drops below 3 psig the device opens to completely drain the trap body. The unit will close at pressures above 3 psig.

### Installation

Thread the Mod. 2000 into the drain connection on the bottom of the F&T trap. Most, but not all, have 3/8" connections. Bush down to 3/8" NPT if connection on the trap is larger. This device will automatically open and drain when the steam trap pressure drops below 3 psig; so, it should not drain in an area where it could dump hot condensate onto personnel. If the trap is where drainage may cause a danger, an open funnel drain with a 1" air gap should be placed under the Mod.2000 to drain condensate to a safe place.

### Maintenance

This is a sealed unit and cannot be dismantled. It is possible that dirt could prevent tight closure. Turn steam off to trap and tap, which may dislodge the debris. Connecting the Mod.2000 to a water hose may allow it to be flushed out. If either tapping or flushing doesn't reseal the Mod.2000, it needs to be replaced.

Model	Mod.2000
PMO	464 psig (32 barg)
Size	3/8"
Connections	NPT
Construction	Tamperproof stainless steel

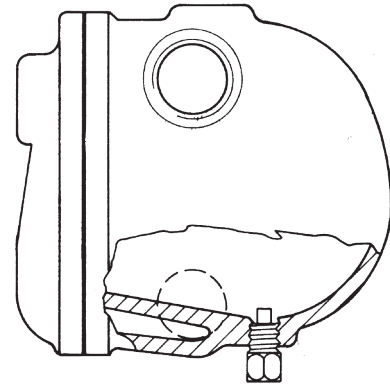

Float & Thermostatic style steam trap with Mod. 2000 drainage device

Spirax Sarco Applications Engineering Department  
Toll Free at: 1-800-575-0394



SPIRAX SARCO, INC. • 1150 NORTHPOINT BLVD. • BLYTHEWOOD, SC 29016  
PHONE 803-714-2000 • FAX 803-714-2222 • [www.spiraxsarco.com/usa](http://www.spiraxsarco.com/usa)