

APT14
Spares 1

Installation and Maintenance Instructions

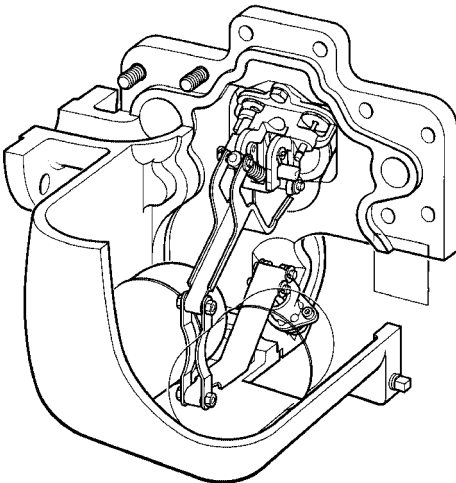

1. *Important safety note*
2. *Replacement of cover gasket*
3. *Replacement of inlet swing check valve*
4. *Replacement of spring and actuator arm*
5. *Replacement of floats*

1. Important - safety note

Before any installation or maintenance procedure, ensure that all steam or condensate lines are isolated.

Ensure any residual internal pressure in the product or connecting lines is carefully relieved. Also ensure any hot parts have cooled to prevent risk of injury from burns.

Always wear appropriate safety clothing before carrying out any installation or maintenance work.

A lifting point is cast into the top of the body. On no account should this be used to lift anything more than the total weight of the product (45 kg / 100 lbs). Always use suitable lifting gear and ensure the product is safely secured.

When dismantling this product, care should be taken to prevent injury from the snap action mechanism.

Always handle with care.

2. Replacement of cover gasket

Please ensure the safety recommendations are observed before commencing with any maintenance of this product.

Tools required

19 mm A/F socket, Flat blade screw driver, Torque wrench

To fit the new cover gasket

1. Disconnect all connections to the cover. Remove the cover bolts using a 19 mm A/F socket, then carefully slide the cover assembly away from the body (250 mm minimum withdrawal distance will be needed). Lift the cover assembly to a bench or other convenient working surface and clamp securely, avoiding contact with the gasket face (See Fig. 1).
2. Gently remove used gasket material from the body and cover, being careful not to damage the gasket sealing faces.
3. Carefully fit a new gasket (item 2) into the existing body (See Fig. 2).
4. **Refit the cover assembly to the body**, ensuring the gasket faces are carefully aligned and no parts of the gasket are trapped or pinched outside the sealing areas. To ensure accurate alignment of the cover and body, it is recommended the lower part of the cover's gasket seal is located into the body first. The top part of the seal can then be easily aligned.
5. Refit the cover bolts ensuring they are sequentially tightened in opposing pairs, gradually increasing torque to 63 ± 5 N m.

Bolt size	Socket size	Tightening torque
M12 x 45	19 mm A/F	63 ± 5 N m

6. Carefully reconnect the motive steam supply and the exhaust lines to the connections marked (IN) and (OUT). The APT14 is now ready to recommission.

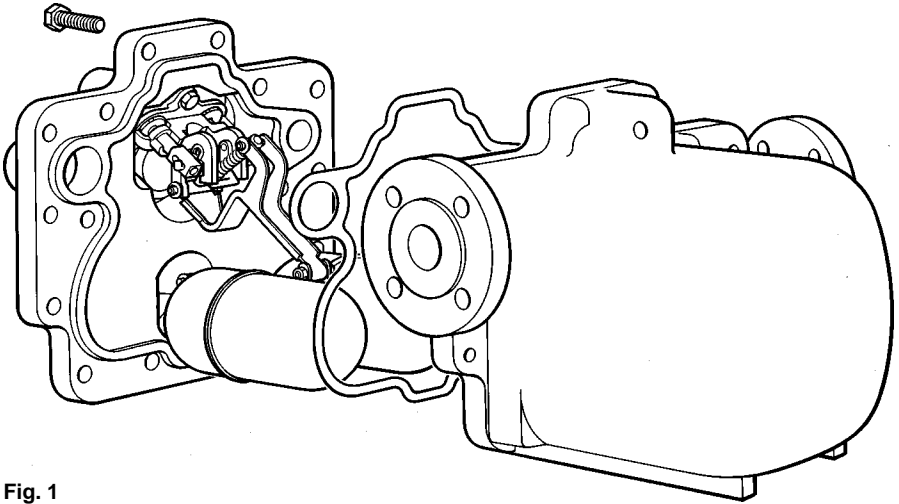

Fig. 1

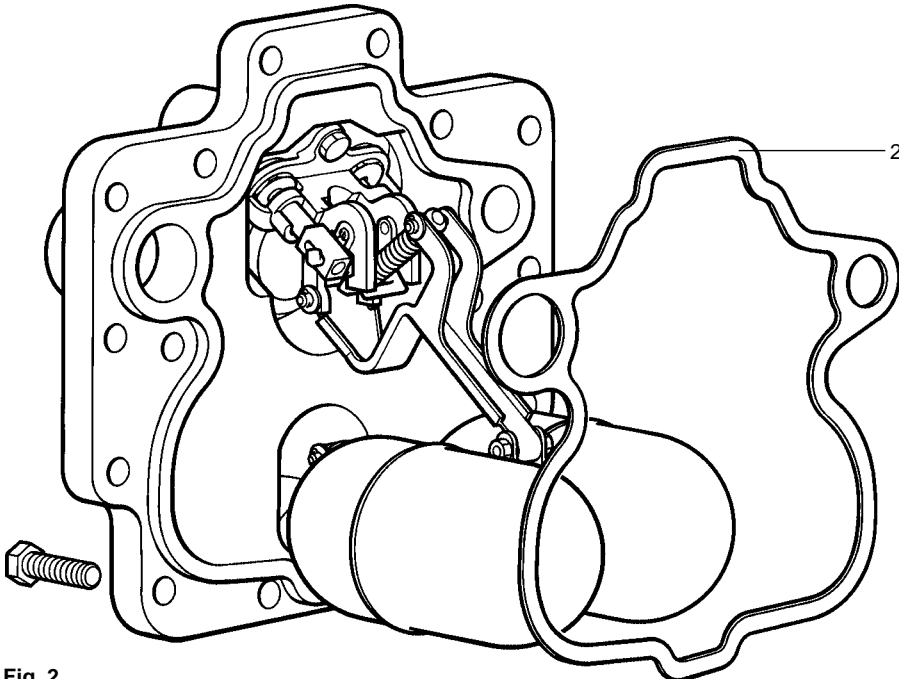

Fig. 2

3. Replacement of inlet swing check valve

Please ensure the safety recommendations are observed before commencing with any maintenance of this product.

Tools required

19 mm A/F socket, 13 mm A/F socket, Flat blade screw driver, Torque wrench, Long nose pliers

To replace the inlet swing check valve

1. Remove the cover and old gasket (see cover gasket replacement procedure, section 2).
2. Lift the cover assembly to a bench or other convenient working surface and clamp securely, avoiding contact with the gasket face.
3. Carefully remove the circlip, washer and the inlet valve spring (item 27) from the end of the steam inlet valve (item 17).
4. Remove the three M8 bolts that secure the pump mechanism bracket using the 13 mm A/F socket.
5. Lift away the pump bracket assembly (See Fig. 3). This will allow access to the inlet swing check valve (item 12).
6. The swing check valve flap can now easily be withdrawn.
7. Fit a new flap, ensuring the face of the check valve flap and seat are clean and free from damage.
8. **Reassembly is the opposite to removal.**
9. Tighten the three M8 bolts using the 13 mm A/F socket to 18 ± 2 N m.
10. It is important to ensure a new circlip is refitted to the steam inlet valve.
11. With the mechanism fully assembled, refit the cover assembly to the body, ensuring the gasket faces are carefully aligned and no parts of the gasket are trapped or pinched outside the sealing areas. To ensure accurate alignment of the cover and body, it is recommended the lower part of the cover's gasket seal is located into the body first. The top part of the seal can then be easily aligned.
12. Refit the cover bolts ensuring they are sequentially tightened in opposing pairs, gradually increasing torque to 63 ± 5 N m.
13. Carefully reconnect the motive steam supply and the exhaust lines to the connections marked (IN) and (OUT). The APT14 is now ready to recommission.

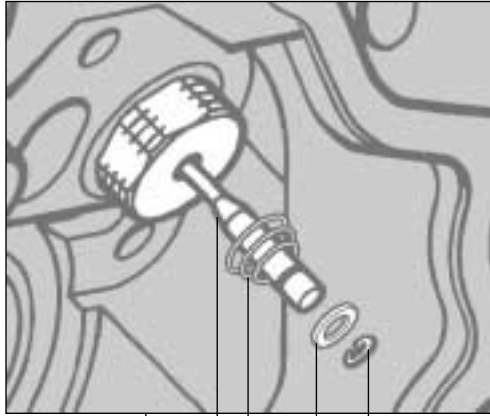

17 27 Washer Circlip

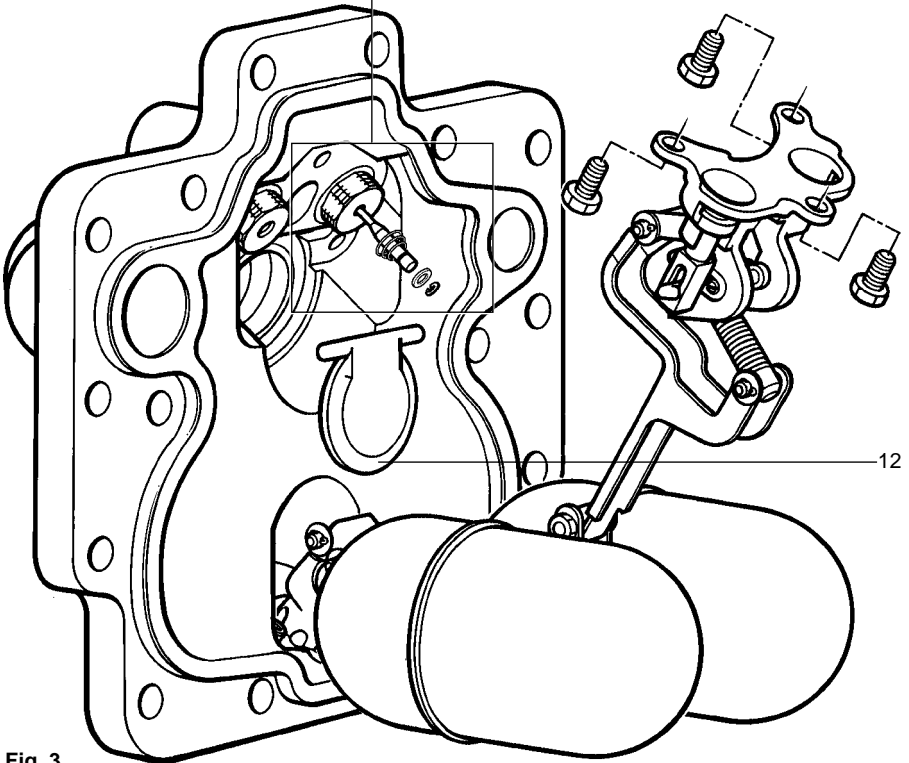

Fig. 3

4. Replacement of spring and actuator arm

Please ensure the safety recommendations are observed before commencing with any maintenance of this product.

Tools required

19 mm A/F socket, Flat blade screw driver, Torque wrench, Long nose pliers

To replace the spring and actuator arm

1. Remove the cover and old gasket (see cover gasket replacement procedure, section 2).
2. Lift the cover assembly to a bench or other convenient working surface and clamp securely, avoiding contact with the gasket face.
3. Ensure the floats are at the bottom of their travel.
4. Remove split pins, washers, and shafts (X and Y) from the top spring pivot and pump pivot points (See Fig. 4).
5. Allow the spring to drop free.
6. Draw the actuator arm downwards within its slots until the whole spring and actuator arm assembly with the exhaust valve comes free. It may be necessary to slide the exhaust valve (item 18) backwards against its internal spring to free it from the pump bracket guide (item 13).
7. Align the slot in the exhaust valve with the tang of the actuator arm.
8. Gently rotate the exhaust valve away from the tanged spigot of the actuator arm (item 24, shown in Fig. 4) being careful not to damage or lose the small exhaust valve compression spring.
9. The spring and actuator arm can both be replaced.
Note: There is no need to remove the spring from the actuator arm, as both these items are supplied fully assembled in the spares kit (See Fig. 5).
10. **Fitting the new spring and actuator arm is the opposite to removal.** Remember to compress the small spring within the exhaust valve (item 18) before refitting to the tanged spigot of the new actuator arm.
11. Ensure the actuator is correctly aligned and located within the slots of the pump bracket (item 13).
12. Once this is correctly located, ensure the exhaust valve can slide easily within its guides.
13. Always use new split pins and washers when refitting the spring retaining shaft (Y) and pump pivot shaft (X).
14. With the mechanism fully assembled, reposition the cover assembly with the body, ensuring the gasket faces are carefully aligned and no parts of the gasket are trapped or pinched outside the sealing areas. To ensure accurate alignment of the cover and body, it is recommended the lower part of the cover's gasket seal is located into the body first. The top part of the seal can then be easily aligned.
15. Refit the cover bolts ensuring they are sequentially tightened in opposing pairs, gradually increasing torque to 63 ± 5 N m.
16. Carefully reconnect the motive steam supply and the exhaust lines to the connections marked (IN) and (OUT). The APT14 is now ready to recommission.

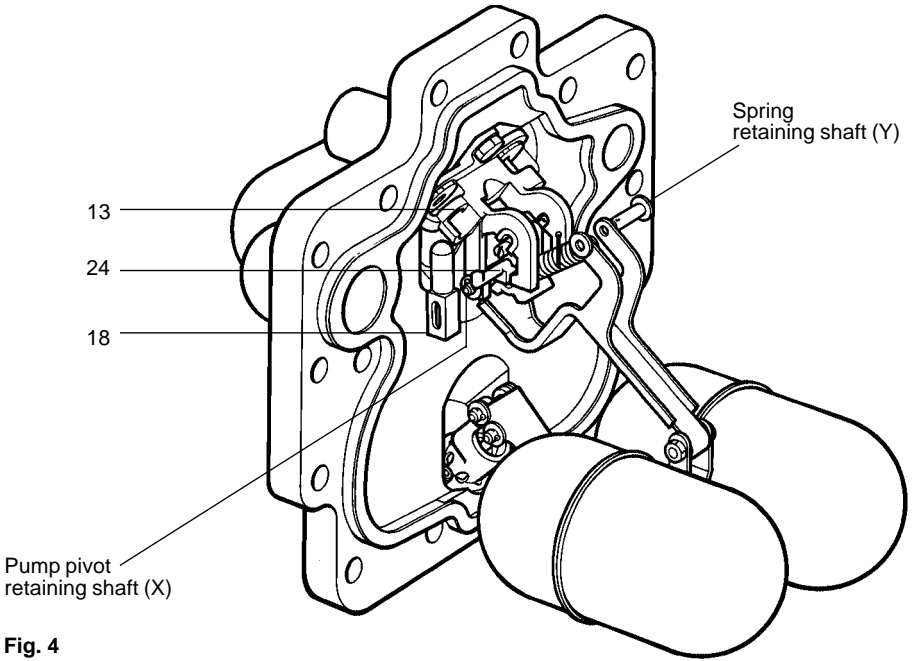

Fig. 4

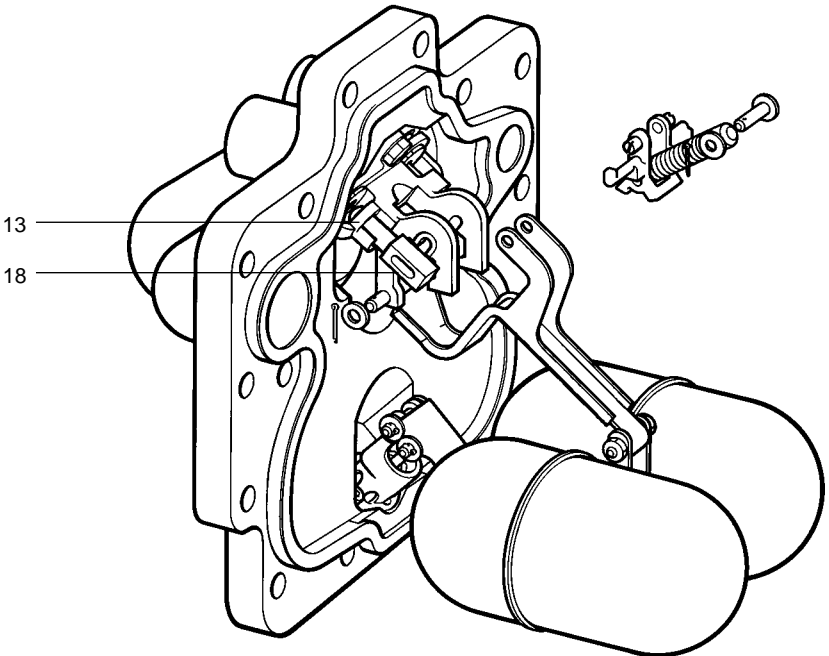

Fig. 5

5. Replacement of floats

Please ensure the safety recommendations are observed before commencing with any maintenance of this product.

Tools required

19 mm A/F socket, Flat blade screw driver, Torque wrench, Long nose pliers

To replace the float and upper / lower levers

1. Remove the cover and old gasket (see cover gasket replacement procedure, section 2).
2. Lift the cover assembly to a bench or other convenient working surface and clamp securely, avoiding contact with the gasket face.
3. Remove a split pin and washer from one side of the spring retaining shaft (Y) (See Fig. 6).
4. Remove a split pin and washer from one side of pump pivot retaining shaft (X).
5. Carefully slide the shafts out from their respective positions observing the orientation of the spring and actuator arm (item 14, 24) within the pump bracket (item 13) as these will need to be refitted later.
6. Remove a split pin and washer from one side of the trap 1st stage valve retaining shaft (W).
7. Remove a split pin and washer from one side of the trap pivot retaining shaft (V).
8. The floats and lever assembly can now be removed and discarded as the replacement floats and levers are supplied fully assembled in the spares kit.
9. **Assembly is the opposite to removal.** Always fit new split pins and washers.
10. It is easier to fit the replacement shafts in the following sequence:- (See Fig. 7).

V. Trap pivot	(shaft length 38 mm)
W. Trap 1st stage valve	(shaft length 38 mm)
X. Pump pivot	(shaft length 52 mm)
Y. Spring retainer	(shaft length 30 mm)

leaving the spring retaining shaft until after the spring and actuator arm have been correctly aligned and located within the slot of the pump bracket (item 13).
Ensure the tanged spigot of the actuator arm is correctly engaged with the exhaust valve.
11. When all the shafts have been secured using new split pins and washers, move the floats to their upper and lower limits to ensure the mechanism operates smoothly and the spring and actuator arm snaps over to operate the motive steam inlet and exhaust valves (items 17, 18).
Note: The mechanism has been designed to be adjustment-free, simplifying the fitting of new parts. If after assembly the mechanism does not operate correctly, check all the parts are assembled and aligned as per the diagram.
12. With the mechanism fully assembled, refit the cover assembly to the body, ensuring the gasket faces are carefully aligned and no parts of the gasket are trapped or pinched outside the sealing areas. To ensure accurate alignment of the cover and body, it is recommended the lower part of the cover's gasket seal is located into the body first. The top part of the seal can then be easily aligned.
13. Refit the cover bolts ensuring they are sequentially tightened in opposing pairs, gradually increasing torque to 63 ± 5 N m.
14. Carefully reconnect the motive steam supply and the exhaust lines to the connections marked (IN) and (OUT). The APT14 is now ready to recommission.

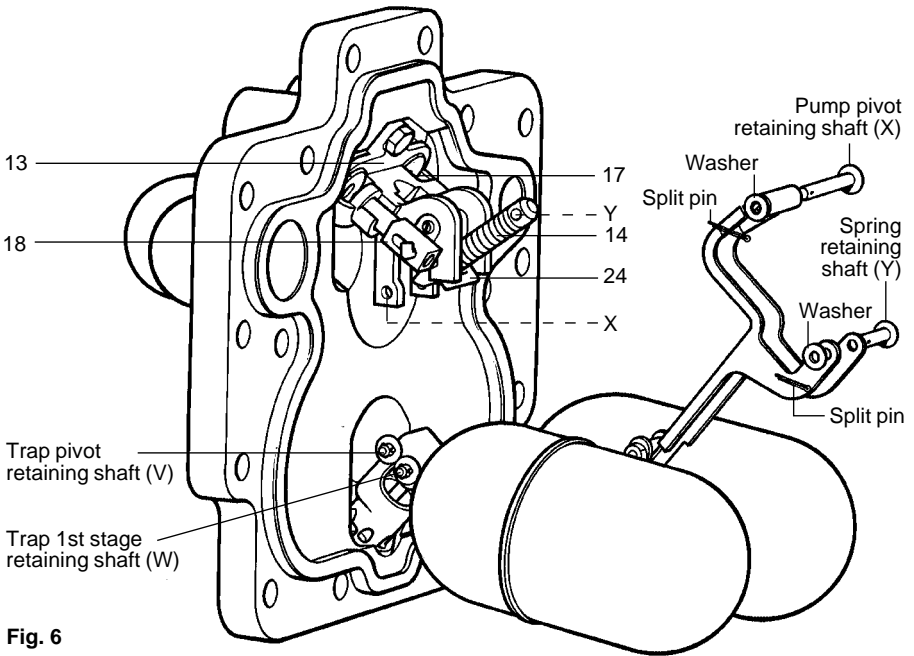

Fig. 6

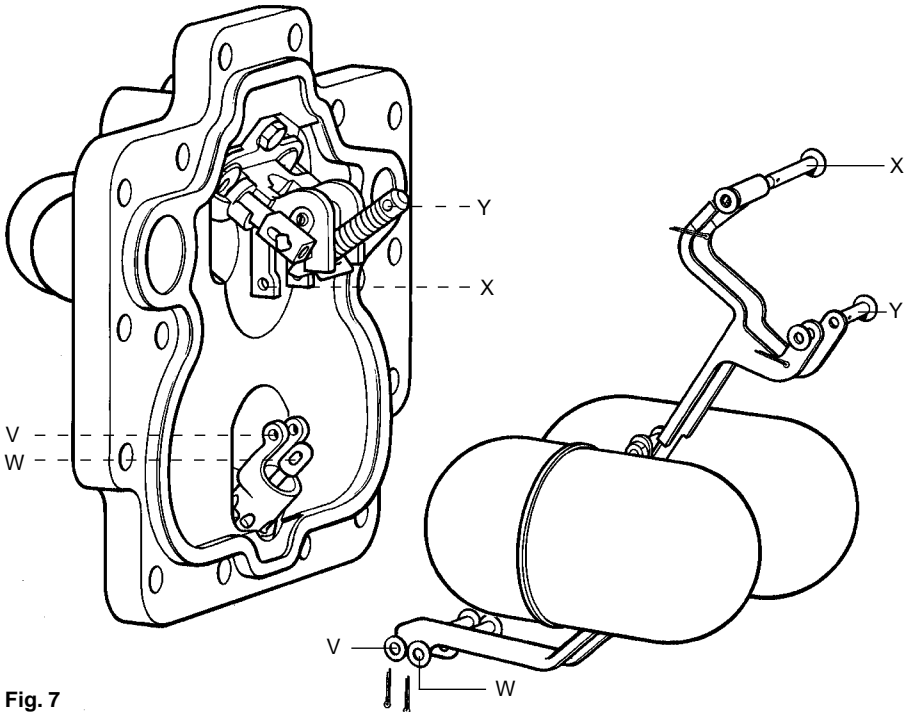

Fig. 7



