

APT10
Spares 2

Installation and Maintenance Instructions

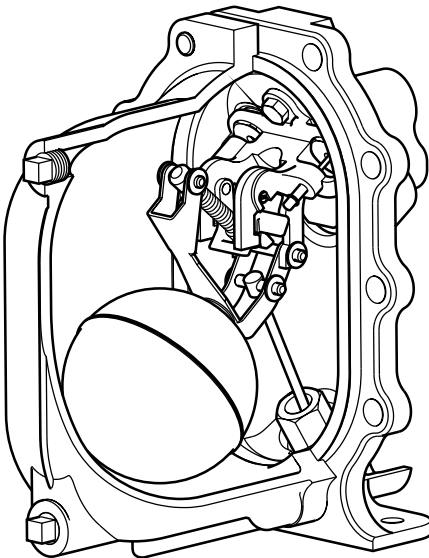

- 1. Important safety note*
- 2. Replacement of trap and outlet check valve mechanism*
- 3. Replacement of Steam inlet / exhaust valves and seats*

1. Safety note

Before any installation or maintenance procedure, ensure that all steam or condensate lines are isolated.

Ensure any residual internal pressure in the product or connecting lines is carefully relieved. Also ensure any hot parts have cooled to prevent risk of injury from burns.

Always wear appropriate safety clothing before carrying out any installation or maintenance work.

Always use suitable lifting gear and ensure the product is safely secured.

When dismantling this product, care should be taken to prevent injury from the snap action mechanism.

Always handle with care.

Disposal

There are no hazardous materials used in the construction of this product.

Any unwanted material should be recycled or disposed of in an environmentally friendly manner.

2. Replacement of trap and outlet check valve mechanism

Please ensure the safety recommendations are observed before commencing with any maintenance of this product.

Tools required

19 mm A/F socket, 24 mm A/F socket, Flat blade screw driver, Torque wrench, Long nose pliers.

To fit the new trap and outlet check valve mechanism

1. Disconnect all connections to the cover. Remove the cover bolts using a 19 mm A/F socket, then carefully slide the cover assembly away from the body (225 mm minimum withdrawal distance will be needed). Lift the cover assembly to a bench or other convenient working surface and clamp securely, avoiding contact with the gasket face.
2. Gently remove used gasket material from the body and cover being careful not to damage the gasket sealing faces.
3. Carefully fit a new gasket (item 2) into the existing body.
4. Remove split pin, washer and shaft from the trap pivot (Z) (See Fig. 1).
5. Remove trap valve stem (item 22) from the mechanism.
6. The float and lever (items 5, 6) can now be swung up out of the way leaving access to the trap and check valve assembly.
7. Using the 24 mm A/F socket unscrew the trap and check valve housing (item 9).
8. The whole trap and check valve assembly can now be carefully withdrawn from the cover.
9. There are no serviceable parts within this assembly; the replacement spares kit contains all new parts.
10. Before fitting a new mechanism, clean the trap housing bore within the cover ensuring any sludge or scale is carefully removed. Remember to fit a new gasket (item 23).

11. Assembly is the opposite to removal.

12. Tighten the 24 mm A/F trap housing to 125 ± 7 N m.

13. Refit the trap valve stem and trap pivot shaft (Z) (length 40 mm) remembering to use new split pins and washers - to the trap lever (item 5).

14. Move the float to its upper and lower limits to ensure the trap mechanism operates smoothly and the valve stem (item 22) slides smoothly within its guide.

15. With the mechanism fully assembled, refit the cover assembly to the body, ensuring the gasket faces are carefully aligned and no parts of the gasket are trapped or pinched outside the sealing areas.

16. Refit the cover bolts ensuring they are sequentially tightened in opposing pairs, gradually increasing torque to 63 ± 5 N m.

Bolt size	Socket size	Tightening torque
M12 x 45	19 mm A/F	63 ± 5 N m

17. Carefully reconnect the motive steam supply and the exhaust lines to the connections marked (S) and (E), and the condensate inlet and outlet to the connections marked (IN) and (OUT). The APT10 is now ready to recommission.

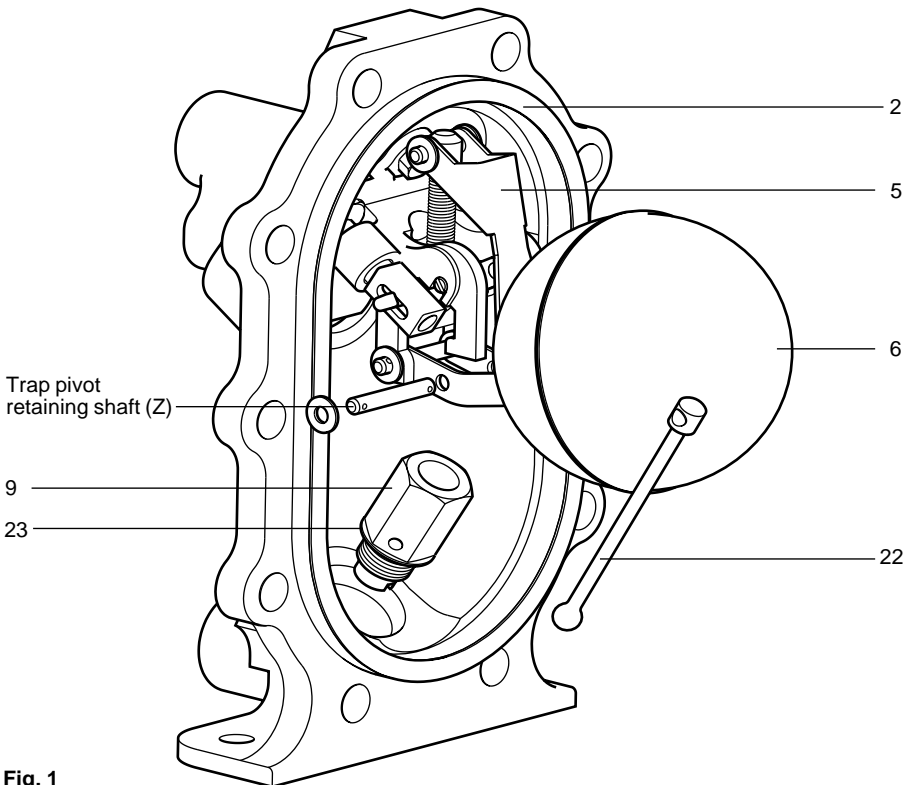

Fig. 1

3. Replacement of steam inlet / exhaust valves and seats

Please ensure the safety recommendations are observed before commencing with any maintenance of this product.

Tools required

13, 19 and 24 mm A/F sockets, Flat blade screw driver, Torque wrench, Long nose pliers

To replace the steam inlet and exhaust valve and seats

1. Remove the cover and old gasket (see cover gasket replacement procedure in Section 2).
2. Lift the cover assembly to a bench or other convenient working surface and clamp securely, avoiding contact with the gasket face.
3. Carefully remove the circlip from the end of the steam inlet valve (item 17).
4. Remove the three M8 bolts (items 20) using the 13 mm A/F socket.
5. Lift away the whole pump bracket assembly as this will allow access to the valve seats.
Note: Do not allow the spring in the pump mechanism to bend back on itself as this may damage the coils and shorten the life of the spring.
6. Using the 24 mm socket unscrew both the steam inlet and exhaust seats.
7. The seats, metal gaskets and steam inlet valve can now be removed.
8. Carefully clean the threads and gasket faces within the cover assembly ensuring all residues are removed.
9. Both seats (items 16) are identical. Insert the replacement steam valve (item 17) according to Fig. 2, with it's sphere located in the threaded end of the new seat.
10. Place a new metal gasket (item 19) onto the threads of the seat before tightening into the cover.
11. Tighten the seat using the 24 mm socket to 125 ± 7 N m.
12. The exhaust seat can be replaced in a similar way.
13. Refit the whole pumpbracket to the cover and tighten the three M8 bolts using the 13 mm A/F socket to 18 ± 2 N m.
14. It is important to ensure a new circlip is fitted to the steam inlet valve after the bracket has been bolted in place.
15. To remove the exhaust valve (item 18), remove split pins, washers, and shaft (Y) from the top spring pivot point. (See Fig. 3).
16. Allow the spring and actuator to drop free.
17. Draw the actuator arm downwards within its slots until the whole spring and actuator arm assembly with the exhaust valve comes free. It may be necessary to slide the exhaust valve backwards against its internal spring to free it from the pump bracket guide (item 13).
18. Align the slot in the exhaust valve (item 18) with the tang of the actuator arm (item 24) (See Fig. 3).
19. Gently rotate the exhaust valve away from the tanged spigot of the actuator arm.
20. **Fitting the replacement exhaust valve is the opposite to removal**, remembering to compress the small spring within the new valve before refitting to the tanged spigot of the actuator arm.

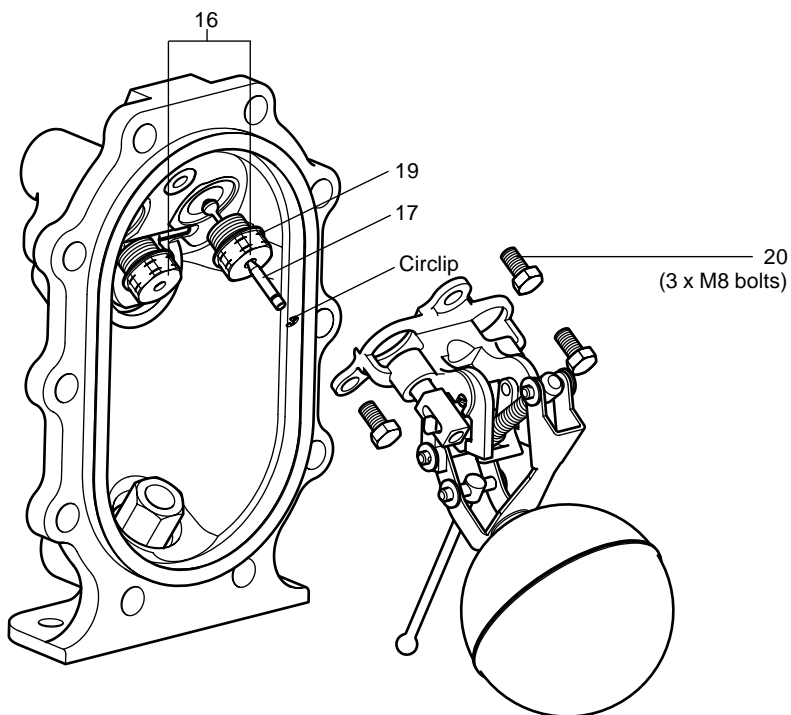

Fig. 2

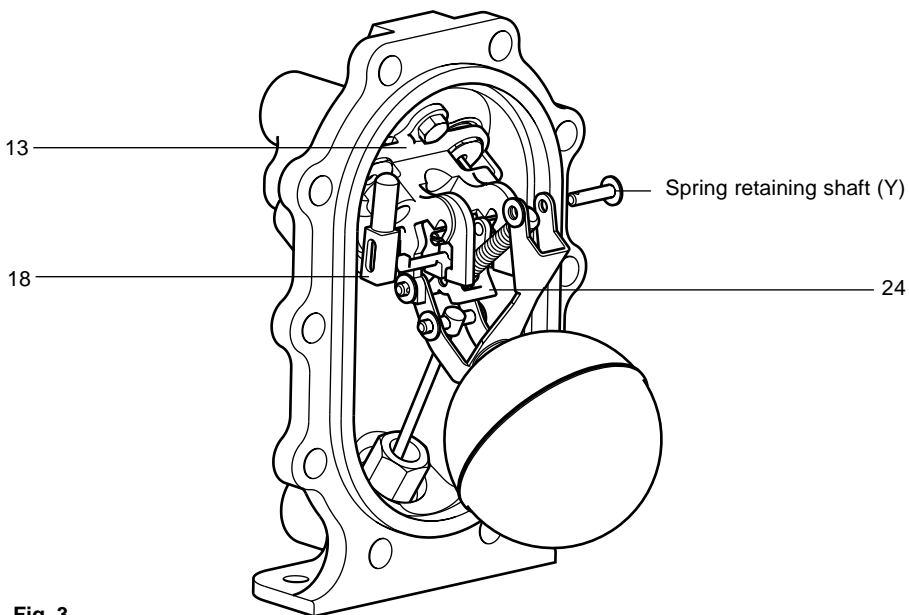

Fig. 3

-
19. Ensure the actuator is correctly aligned and located within the slots of the pump bracket (item 13).
 20. Once this is correctly located, ensure the exhaust valve can slide easily within its guides.
 21. Always use new split pins and washers when refitting the spring retaining shaft (Y) (30 mm long).
 22. Check that the mechanism snaps over and opens and closes the valves by moving the float to its upper and lower limit of travel.
Note: The valve gear has been designed to be adjustment-free, simplifying the fitting of new parts. If after assembly the mechanism does not operate correctly, check all the parts are assembled and aligned as per Fig. 4.
 23. With the mechanism fully assembled, refit the cover assembly to the body, ensuring the gasket faces are carefully aligned and no parts of the gasket are trapped or pinched outside the sealing areas.
 24. Refit the cover bolts ensuring they are sequentially tightened in opposing pairs, gradually increasing torque to 63 ± 5 N m.
 25. Carefully reconnect the motive steam supply and the exhaust lines to the connections marked (S) and (E) and the condensate inlet and outlet to the connections marked (IN) and (OUT). The APT10 is now ready to recommission.

13

Spring retaining shaft (Y)

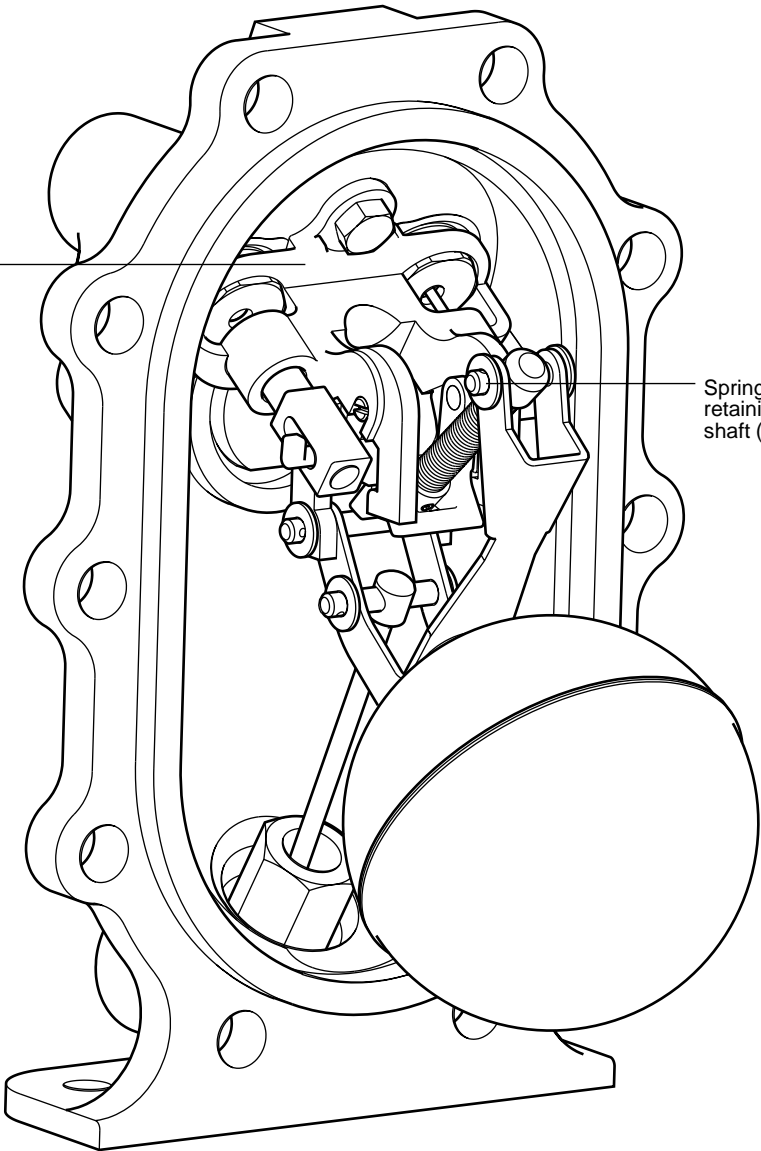

Fig. 4

