



# M21Fi ISO

## Reduced Bore Firesafe API607 Ball Valve

### DN15 to DN150 Flanged PN40

#### Description

The M21Fi is a reduced bore ball valve, with a single piece body, having ISO mounting as standard. It is designed to be an isolating valve, which can be used with the majority of industrial fluids, not a control valve.

#### Firesafe design

In normal working conditions, the ball rests against two PDR 0.8 seats ensuring total closure. When the valve is submitted to temperature above the limits the seats can withstand, the seat becomes deformed and renders to extrusion. When the seats have been totally destroyed, the ball will come to rest firmly against the metal seat in the cap, producing a metal-to-metal closing. This secondary seat in the valve cap ensures the valve will operate to international API 607 standard.

#### Available types

**M21Fi2 ISO** Zinc plated carbon steel body, PDR 0.8 seats.

**M21Fi3 ISO** Stainless steel body, PDR 0.8 seats.

#### Standards

This product fully complies with the requirements of the Pressure Equipment Directive (PED) and carries the **CE** mark when so required.

#### Certification

This product is available with certification to EN 10204 3.1.  
**Note:** All certification/inspection requirements must be stated at the time of order placement.

#### Pressure/temperature limits

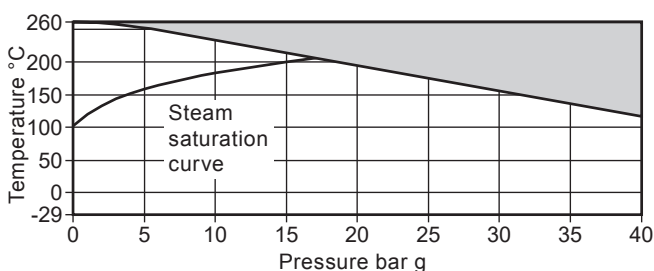

The product **must not** be used in this region.

Body design conditions	PN40
PMA Maximum allowable pressure	40 bar g @ 120 °C
TMA Maximum allowable temperature	260 °C @ 0 bar g
Minimum allowable temperature	-29 °C
PMO Maximum operating pressure for saturated steam service	17.5 bar g
TMO Maximum operating temperature	260 °C @ 0 bar g
Minimum operating temperature	-29 °C
<b>Note:</b> For lower operating temperatures consult Spirax Sarco	
ΔPMX Maximum differential pressure is limited to the PMO	
Designed for a maximum cold hydraulic test pressure of 60 bar g	

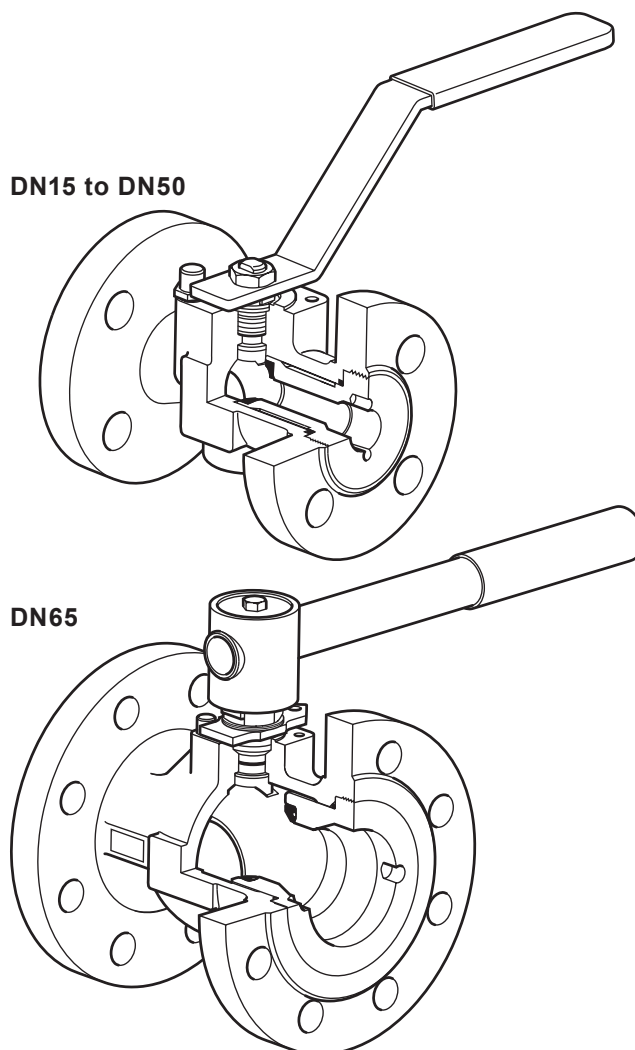

#### Sizes and pipe connections

DN15, DN20, DN25, DN32, DN40, DN50, DN65, DN80, DN100 and DN150

**Standard flange:** EN 1092 PN40

**Face-to-face dimensions:**

- DN15 to DN100 according to DIN 3202 F4.
- DN25 to DN150 according to BS 2080.

#### Technical data

Flow characteristic	Modified linear
Port	Reduced bore
Leakage test procedure to ISO 5208 (Rate A)/EN 12266-1 (Rate A)	
Antistatic device	Complies with ISO 7121 and BS 5351

## DN15 to DN50

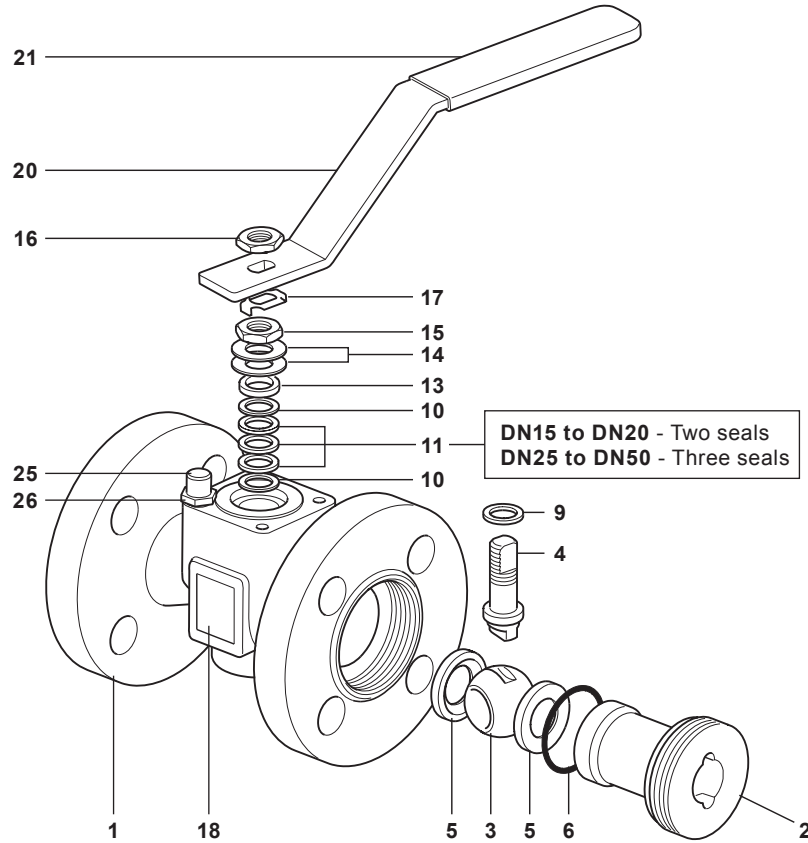

### Materials

No.	Part		Material	
1	Body	M21Fi2 ISO	Zinc plated carbon steel	ASTM A216 WCB
		M21Fi3 ISO	Stainless steel	ASTM A351 CF8M
2	Insert	M21Fi2 ISO	Zinc plated carbon steel	SAE 1040
		M21Fi3 ISO	Stainless steel	AISI 316
3	Ball		Stainless steel	AISI 316
4	Stem		Stainless steel	AISI 316
5	Seat		Carbon and graphite reinforced PTFE	PDR 0.8
6	Insert gasket		Graphite	
9	Stem seal		Antistatic R-PTFE	
10	Stem seal		Stainless steel	AISI 304
11	Stem seal		Graphite	
13	Separator		Zinc plated carbon steel	SAE 1010
14	Belleville washer		Stainless steel	AISI 301
15	Gland nut		Zinc plated carbon steel	SAE 1010/SAE 12L14
16	Upper stem nut		Zinc plated carbon steel	SAE 1010/SAE 12L14
17	Locking plate		Stainless steel	AISI 304
18	Nameplate		Stainless steel	AISI 430
20	Lever		Zinc plated carbon steel	SAE 1010
21	Grip		Vinyl	Red
25	Stop screw		Zinc plated carbon steel	SAE 12L14
26	Split lock washer		Stainless steel	AISI 304

## DN65

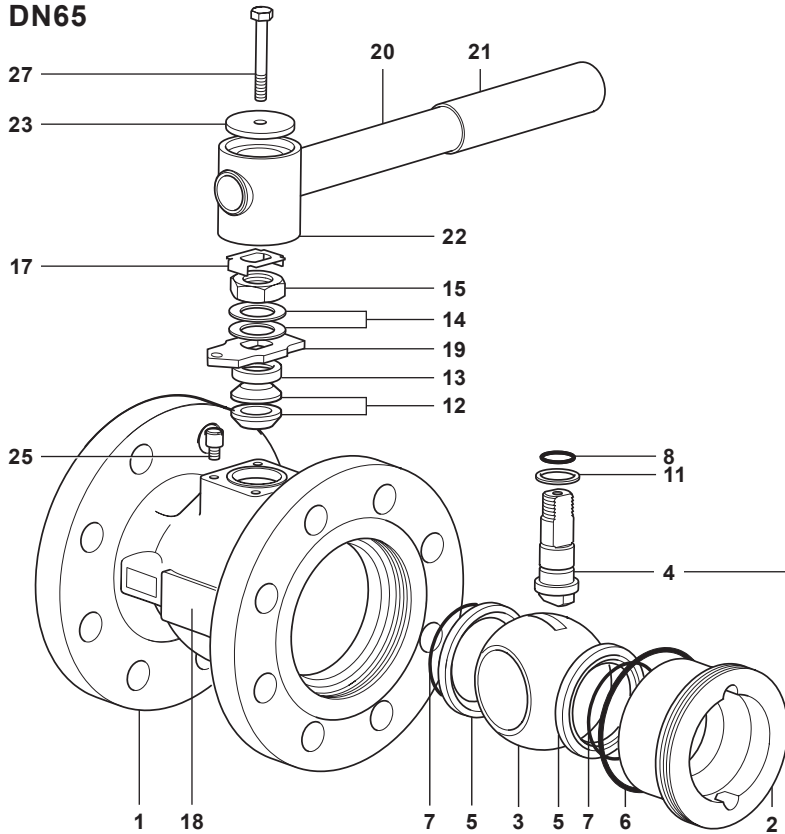

## DN80 to DN150

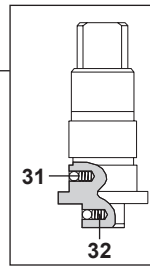
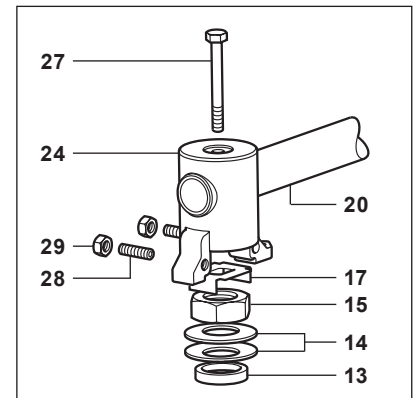

## Materials

No.	Part		Material	
1	Body	M21Fi2 ISO	Zinc plated carbon steel	ASTM A216 WCB
		M21Fi3 ISO	Stainless steel	ASTM A351 CF8M
2	Insert	M21Fi2 ISO	Zinc plated carbon steel	SAE 1040
		M21Fi3 ISO	Stainless steel	AISI 316
3	Ball		Stainless steel	AISI 316
4	Stem		Stainless steel	AISI 316/AISI 420
5	Seat		Carbon and graphite reinforced PTFE	PDR 0.8
6	Insert gasket		Graphite	
7	Seat 'O' ring		EPDM	Geothermal
8	Stem 'O' ring		EPDM	Geothermal
11	Lower stem seal		Antistatic R-PTFE	
12	Upper stem packing		Graphite	
13	Separator		Zinc plated carbon steel	SAE 1010
14	Belleville washer		Carbon steel/Stainless steel	
15	Gland nut		Zinc plated carbon steel	SAE 1010/SAE 12L14
17	Locking plate		Stainless steel	AISI 304
18	Nameplate		Stainless steel	AISI 430
19	Stop plate with indicator	DN65 only	Zinc plated carbon steel	SAE 1010
20	Lever		Zinc plated carbon steel	SAE 1010
21	Grip		Vinyl	Red
22	Adaptor	DN65 only	Zinc plated SG iron	
23	Adaptor plate	DN65 only	Zinc plated carbon steel	SAE 1010
24	Adaptor with indicator	DN80 to DN150	Zinc plated SG iron	
25	Stop screw		Zinc plated carbon steel	SAE 12L14
27	Adaptor screw		Zinc plated carbon steel	Grade 5
28	Stop screw	DN80 to DN150	Carbon steel	
29	Adaptor hex. nut	DN80 to DN150	Zinc plated carbon steel	
31	Antistatic device ball		Stainless steel	AISI 302
32	Antistatic device spring		Stainless steel	AISI 301

**Dimensions/weights (approximate) in mm and kg  
PN40 DIN 3202 F4 flanges**

Size	A	B	C	D	E	F	Weight
DN15	115	57	162	95	95	13	2.5
DN20	120	60	162	105	95	13	3.2
DN25	125	62	162	115	101	19	4.0
DN32	130	65	182	140	106	25	5.5
DN40	140	70	186	150	118	30	6.9
DN50	150	75	186	165	123	37	9.3
DN65	170	79	278	185	144	50	13.4
DN80	180	91	417	200	157	57	17.7
DN100	190	98	517	235	172	75	25.0
DN150	-	-	-	-	-	-	-

**PN40 BS 2080 flanges**

Size	A	B	C	D	E	F	Weight
DN15	-	-	-	-	-	-	-
DN20	-	-	-	-	-	-	-
DN25	165	62	162	115	101	19	4.2
DN32	178	65	182	140	106	25	5.9
DN40	190	70	186	150	118	30	7.4
DN50	216	75	186	165	123	37	10.2
DN65	241	79	278	185	144	50	14.9
DN80	283	91	417	200	157	57	20.2
DN100	305	98	517	235	172	75	29.4
DN150	403	130	700	300	205	100	56.9

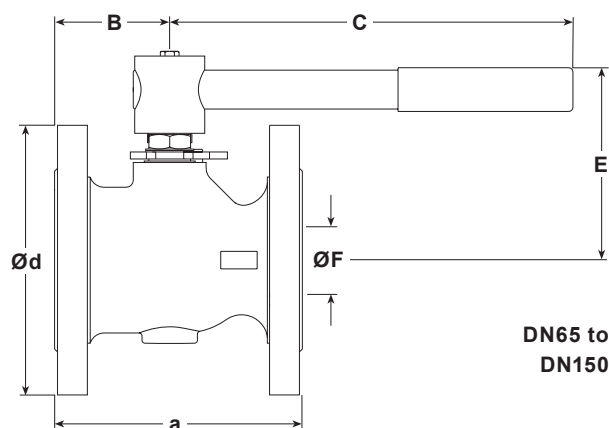
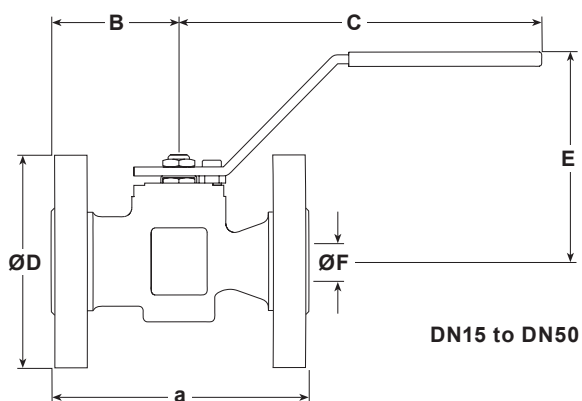

**K<sub>v</sub> values**

DN	15	20	25	32	40	50	65	80	100	150
K <sub>v</sub>	10	10	30	40	81	103	197	248	581	735

For conversion

$$C_V (\text{UK}) = K_V \times 0.963$$

$$C_V (\text{US}) = K_V \times 1.156$$

**Operating torque (N m)**

DN	15	20	25	32	40	50	65	80	100	150
N m	8	8	10	15	20	25	80	70	100	155

**Note:** The torque figures shown are for a valve that is frequently operated at the maximum operating pressure. Valves that are subject to long static periods, may require a greater break-out torque.

**Safety information, installation and maintenance**

For full details see the Installation and Maintenance Instructions supplied with the product.

**Welding**

Only the models that have connections designed for welding (SW, BW, Imperial Tube connections) should be welded. Valves with flanged connections must not be welded to avoid damages to the valve and/or injury to personnel.

**How to order**

Specify	Model	Seat material	F = Carbon and graphite reinforced PTFE - PDR 0.8
	Material	Body material	2 = Zinc plated carbon steel
			3 = Stainless steel

**Example:** 1 off Spirax Sarco DN50 M21Fi2 ISO ball valve having flanged EN 1092 PN40 connections. Face-to-face according to BS 2080.

**Optional extras:**

- Self-venting ball.
- Extended stems to allow full insulation: 50 mm (2") for DN15 to DN50 sizes and 100 mm (4") for DN65 to DN150 sizes.
- Lockable handle.
- 100 mm extended stem with lockable handle.

## DN15 to DN50 - Spare parts (see page 6 for sizes DN65 - DN150)

The spare parts available are shown in solid outline. Parts drawn in a grey line are not supplied as spares.

### Available spares

Seats, insert gasket and stem seals

5, 6, 9, 10, 11

### How to order spares

Always order spares by using the description given in the column headed 'Available spares' and state the size and type of ball valve.

**Example:** 1 set of seats, insert gasket and stem seals for a Spirax Sarco DN50 flanged PN40 M21Fi2 ball valve.

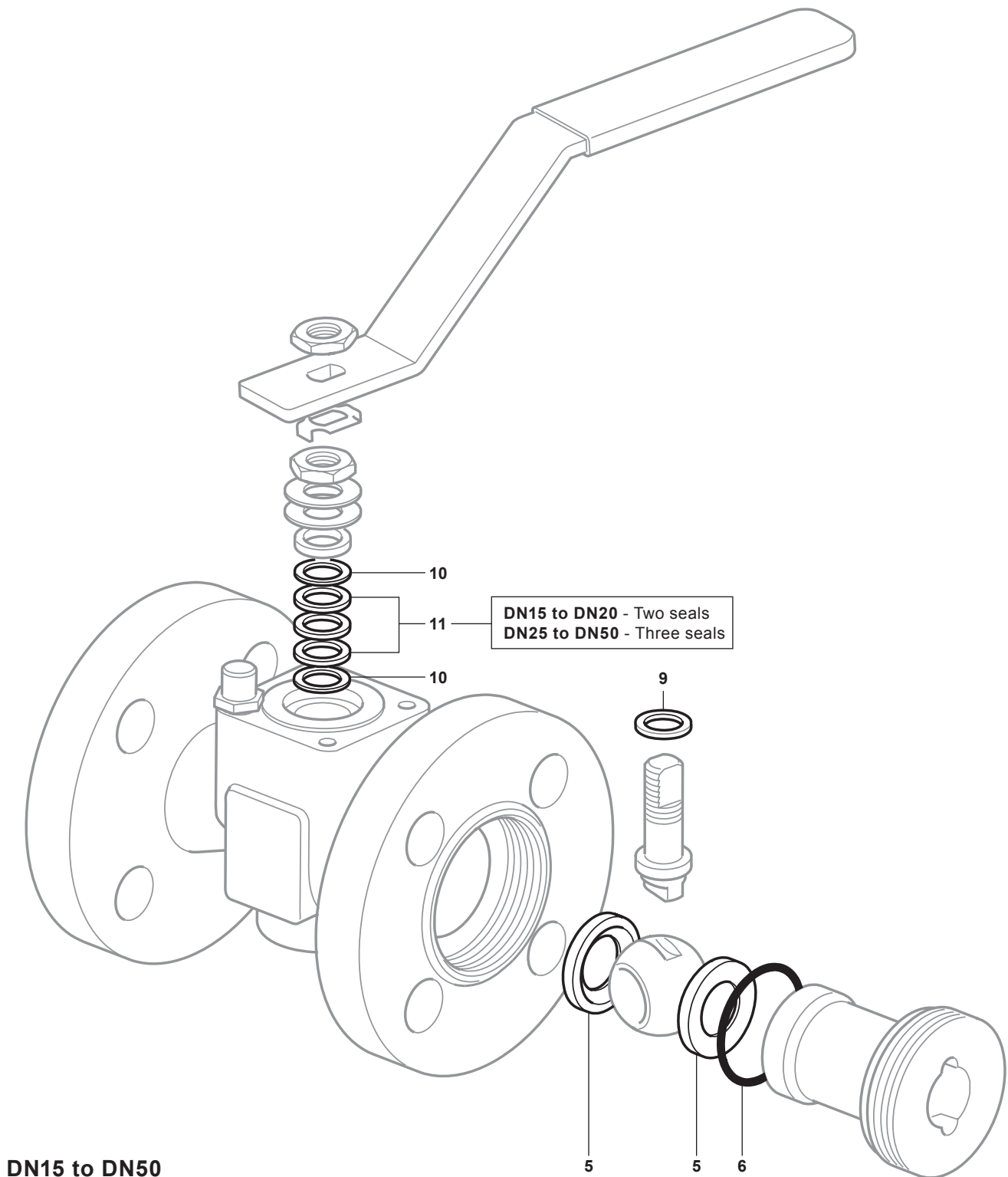

## DN65 to DN150 - Spare parts (see page 5 for sizes DN15 - DN50)

The spare parts available are shown in solid outline. Parts drawn in a grey line are not supplied as spares.

### Available spares

Seats, insert gasket, seat 'O' ring, stem 'O' ring, lower stem seal and upper stem packing

5, 6, 7, 8, 11, 12

### How to order spares

Always order spares by using the description given in the column headed 'Available spares' and state the size and type of ball valve.

**Example:** 1 set of seats, insert gasket, seat 'O' ring, stem 'O' ring, lower stem seal and upper stem packing for a Spirax Sarco DN50 flanged PN40 M21Fi2 ball valve.

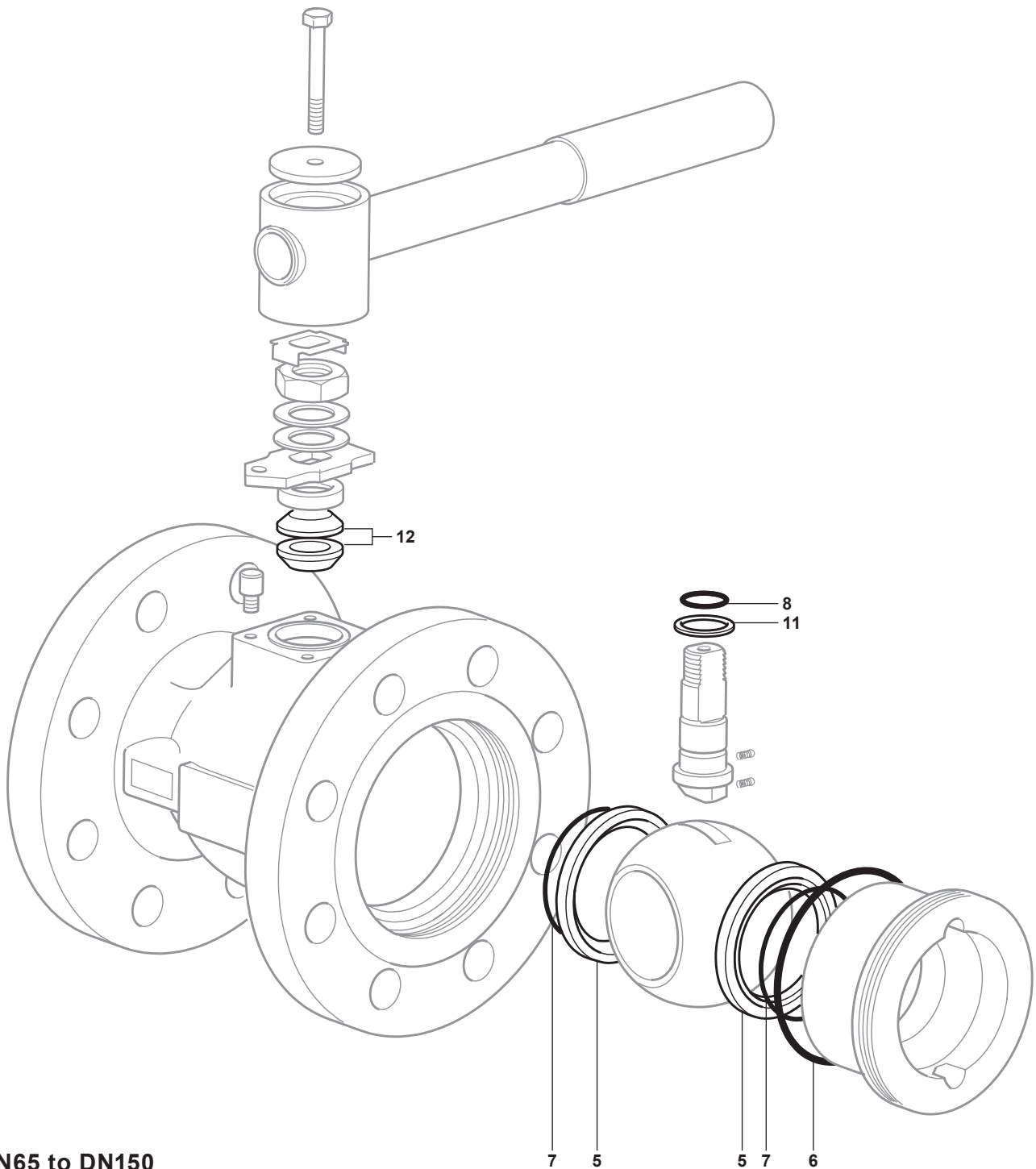

DN65 to DN150