



LCR2652 BHD50 Level Controller, Operating and Display Unit

Description

The functional unit consisting of the operating and display unit BHD50 and the LCR2652 level controller in conjunction with level transmitter LP20/LP21/PA420 is used as water level controller and as a limit switch, for instance in steam boilers, (pressurized) hot-water installations as well as condensate and feedwater tanks. One BHD50 can be used with a LCR2652 and a BCR3250 controller to provide a combined level and TDS control system.

A level limit switch (LCS3050 and/or LCS3051) can be connected to the LCR2652 to signal and log level alarms on the BHD50.

The LCR2652 level controller processes the level-dependent current signal from the LP20/LP21/PA420 level transmitter. This input signal is recognised by the controller as 0 and 100 % of the boiler measuring range.

The operating and display unit BHD50 and the level controller LCR2652 form a functional unit featuring the following properties:

- 3-position stepping controller with proportional-plus-integral control action (PI controller) and control of an electrically actuated control valve (VMD - Valve Motor Drive)
- Continuous controller as PI controller for the control of an electro-pneumatically operated control valve and a relay for pump ON/OFF control
- Indication of MIN/MAX water level limit
- Fill or discharge control
- Level damping filter
- Current inputs for steam and feedwater flowrate (2 or 3-element control)
- Actual value output 4-20 mA
- Level limit switch alarm input (24Vdc), to display the status of any LCS3050 or LCS3051 level limit switch
- Indication of actual value (indicated in percent and as bar graph)
- Standardized measuring range when the level transmitter LP20/LP21/PA420 is connected
- Indication/adjustment of control parameters
- Adjustment and evaluation of current inputs for steam and feedwater flowrate (2 or 3-element control)
- Trend record
- Indication and listing of errors, alarms and warnings
- Test of MIN/MAX output relays
- Manual/automatic operation
- Modbus RTU (RS232, RS422 or RS485) and Modbus TCP (Ethernet 10/100Mb) communication
- Password protection

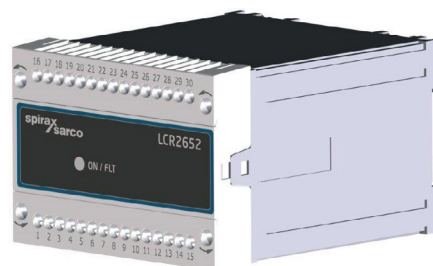

BHD50



Typical applications

- Steam Boilers
- Hot-Water Installations
- Condensate and Feedwater Tanks

Technical data LCR2652

Supply voltage	24 Vdc +/- 20%
Fuse	external 0.5 A (semi-delay)
Power consumption	5 W
Connection of level transmitter	1 analogue input 4-20 mA, e. g. for level transmitter LP20/LP21/PA420, with 2 poles and screen
Supply voltage of level transmitter	12 Vdc
Inputs	1 analogue input 4-20 mA (steam flowrate) 1 analogue input 4-20 mA (feedwater flowrate) 1 volt-free digital input (level limit alarm switch), 24 Vdc +/- 20%, 10mA
Outputs	1 or 2 volt-free change-over contacts, 8 A 250 Vac/30 Vdc $\cos \phi = 1$ (pump/VMD control) 2 volt-free change-over contacts, 8 A 250 Vac/30 Vdc $\cos \phi = 1$ De-energizing delay: 3 seconds (MIN/MAX alarm) 1 analogue output 4-20 mA, max. load 500 ohm (manipulated variable Y) 1 analogue output 4-20 mA, max. load 500 ohm (actual value indication) Provide inductive loads with RC combinations according to manufacturer's specification to ensure interference suppression
Data line	1 interface for data exchange with operating and display unit BHD50
Indicators and adjustors	1 tri-colour LED indicator (start-up = amber, power ON = green, malfunction = red) 1 code switch with four poles for configuration
Housing	Housing material: base: polycarbonate, black; front: polycarbonate, grey Conductor size: 1 x 4,0 mm ² solid per wire or 1 x 2.5 mm ² per stranded wire with sleeve to DIN 46228 or 2 x 1.5 mm ² per stranded wire with sleeve to DIN 46228 (min. Ø 0.1 mm) terminal strips can be detached separately Fixing of housing: Mounting clip on supporting rail TH 35, EN 60715
Electrical safety	Pollution degree 2 for installation in control cabinet with protection IP 54, completely insulated
Protection	Housing: IP 40 to EN 60529 Terminal strip: IP 20 to EN 60529
Weight	approx. 0.5 kg
Ambient temperature	when system is switched on: 0° ... 55 °C, during operation: -10 ... 55 °C
Transport temperature	-20 ... +80 °C (<100 hours), defrosting time of the de-energized equipment before it can be put into operation: 24 hours
Storage temperature	-20 ... +70 °C, defrosting time of the de-energized equipment before it can be put into operation: 24 hours
Relative humidity	max. 95%, no moisture condensation

Wiring diagrams

Wiring diagram (LCR2652) - Valve Motor Drive Controller (VMD)

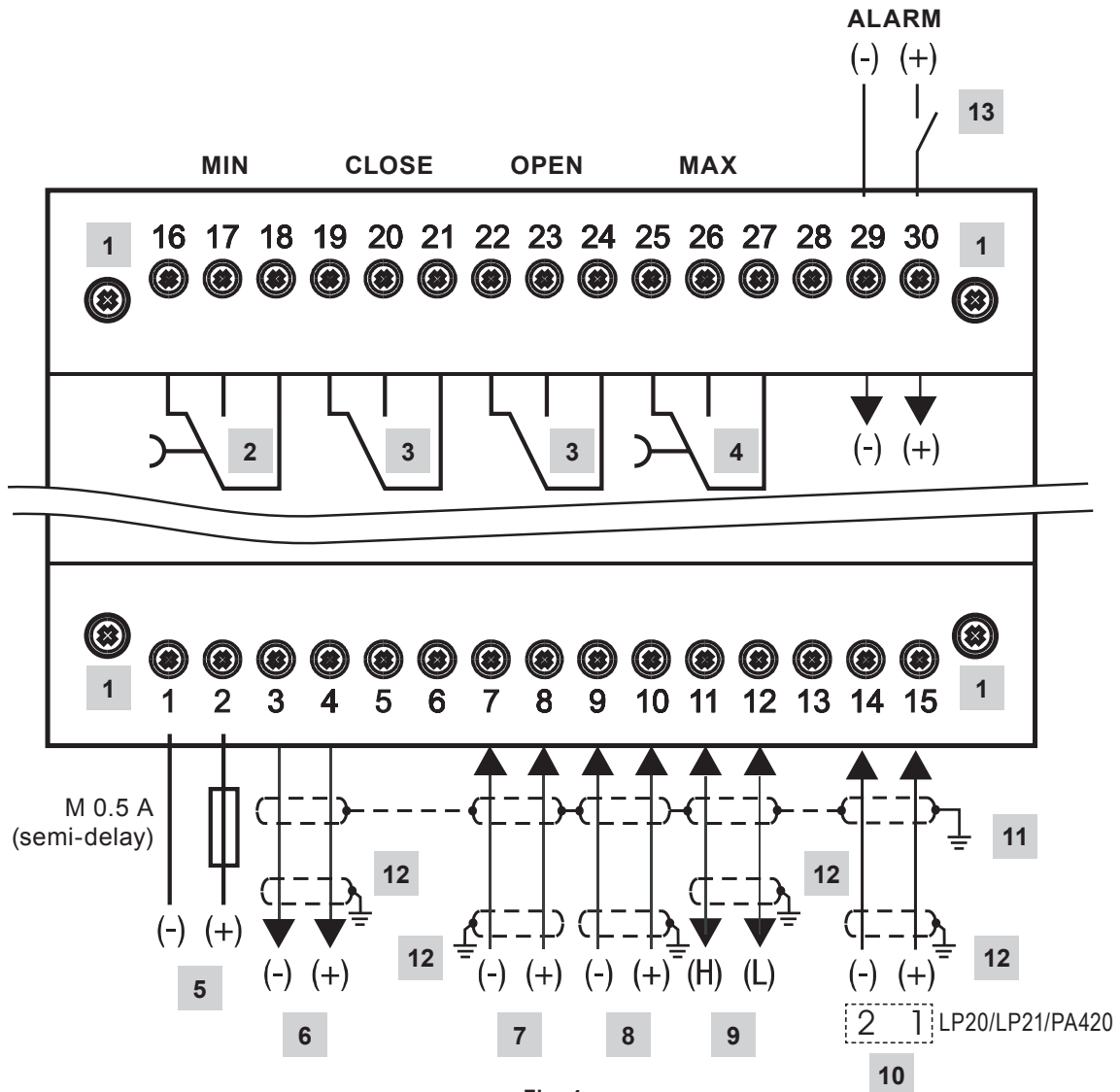

Fig. 4

Item	
1	Fixing screws for terminal strip
2	MIN output contact, de-energizing delay: 3 sec.
3	Output contacts for activating the control valve. External link wire necessary for function
4	MAX output contact, de-energizing delay: 3 sec.
5	Connection of supply voltage 24 Vdc with fuse 0.5 A (semi-delay) provided on site
6	Actual value output 4-20 mA
7	Feedwater flowrate input, 4-20 mA
8	Steam flowrate input, 4-20 mA
9	Data line for operating and display unit BHD50
10	Level transmitter LP20/LP21/PA420, 4-20 mA
11	Central earthing point (CEP) in control cabinet
12	Earthing point at the auxiliary equipment (e.g. PA420/LP20/LP21)
13	Input for level limit switch (24Vdc), ON = alarm, OFF = normal water level

Wiring diagram (LCR2652)

For continuous controller (4 - 20 mA) or Pump ON/OFF controller

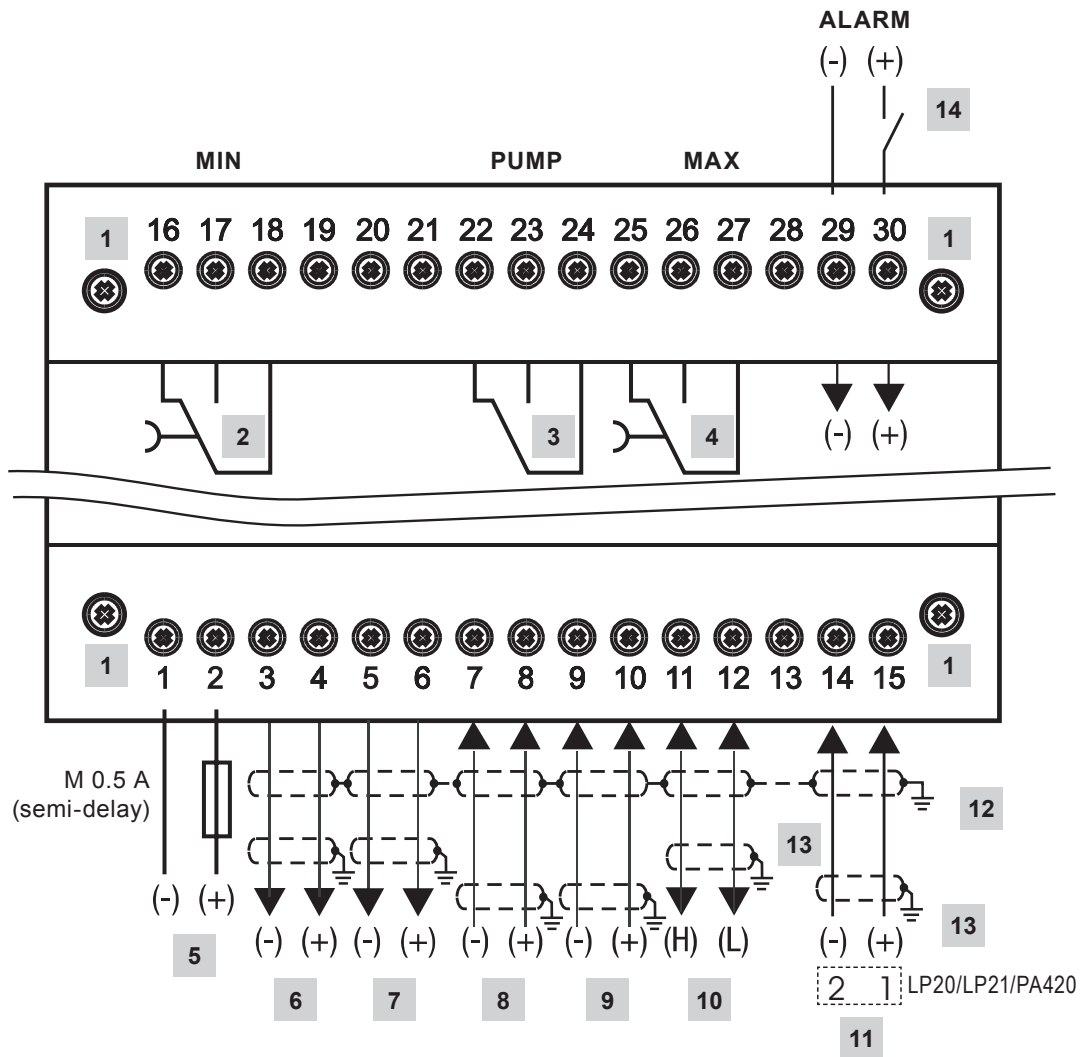

Fig. 5

Item	
1	Fixing screws for terminal strip
2	MIN output contact, de-energizing delay: 3 sec.
3	Pump output contact
4	MAX output contact, de-energizing delay: 3 sec.
5	Connection of supply voltage 24 Vdc with fuse 0.5 A (semi-delay) provided on site
6	Actual value output 4-20 mA
7	Output 4-20 mA manipulated variable Y
8	Feedwater flowrate input, 4-20 mA
9	Steam flowrate input, 4-20 mA
10	Data line for operating and display unit BHD50
11	Level transmitter LP20/LP21/PA420, 4-20 mA.
12	Central earthing point (CEP) in control cabinet
13	Earthing point at the auxiliary equipment (e.g. PA420/LP20/LP21)
14	Input for level limit switch (24Vdc), ON = alarm, OFF = normal water level

Technical data BHD50

Supply voltage	24 Vdc +/- 20%
Fuse	internal automatic
Power consumption	14.4 W
User interface	5" colour display with analogue capacitive touch screen, resolution 800 x 480 pixels, illuminated
Communication interface	RS232, RS422, RS485 and Ethernet 10/100Mb (USB for maintenance only)
Data line	For connection to a LCR2652 and BCR3250 (in parallel)
Dimensions	Front panel: 147x107 mm Panel cut-out: 136x96 mm Depth: 52 + 8 mm
Weight	approx. 1.3 kg
Protection	Front: IP 66 to EN 60529 Rear: IP 20 to EN 60529
Electrical connection	1 power connector with 3 poles 1 D-SUB connector with 9 poles 2 Ethernet (10/100Mb) RJ45 connector 1 USB Port V2.0, max. 500 mA - for maintenance only 1 Serial connector with 8 poles

Directives and standards

VdTÜV Bulletin "Wasserstand 100" (Water Level 100)

The functional unit consisting of the operating and display unit BHD50/level controller LCR2652 in conjunction with level transmitter LP20/LP21/PA420 is type approved to the VdTÜV Bulletin "Water Level 100".

The VdTÜV Bulletin "Wasserstand (Water Level) 100" specifies the requirements made on water level control and limiting equipment for boilers.

Type approval no. TÜV · WR · XX-XXX (see name plate).

LV (Low Voltage) Directive and EMC (Electromagnetic Compatibility)

The equipment meets the requirements of the Low Voltage Directive 2014/35/EU and the EMC Directive 2014/30/EU.

ATEX (Atmosphère Explosible)

According to the European Directive 2014/34/EU the equipment must not be used in explosion risk areas.

Dimensions (LCR2652) (approximate) in mm

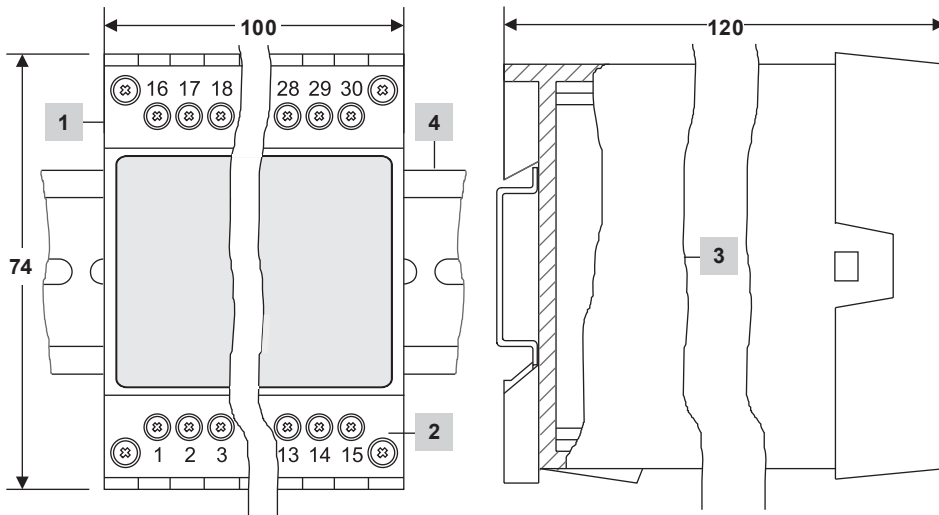

Item	
1	Upper terminal strip
2	Lower terminal strip
3	Housing
4	Support rail TH 35, EN 60715

The blowdown controller LCR2652 is clipped onto the support rail type TH 35, EN 60715 in the control cabinet. Item 4.

Dimensions (BHD50) (approximate) in mm

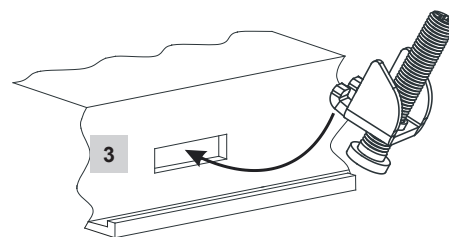
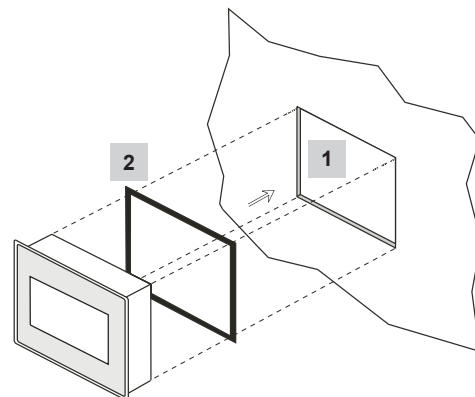
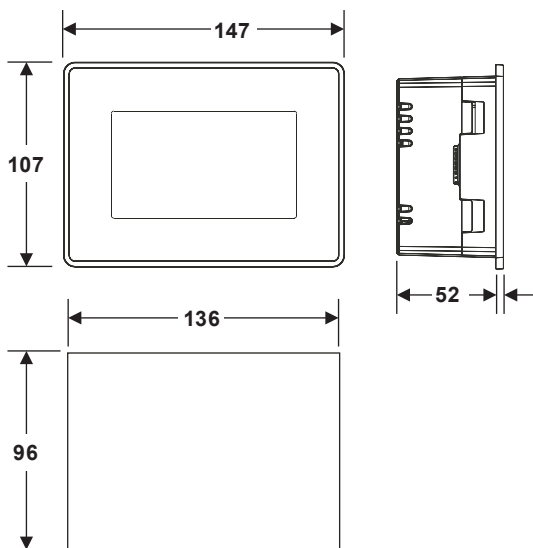

Fixing element detail.

Item	
1	Cut-out in control cabinet 136 x 96 mm
2	Gasket
3	Fixing elements

How to specify

Level Controller with Operating and Display Unit, 4 volt-free change-over contacts for MIN/MAX alarm & control valve supply voltage 24V DC 4W.

How to order

Example: 1 off Spirax Sarco LCR2652 Level Controller, 1 off Spirax Sarco BHD50 Operating and Display Unit.