



TI-P504-19
 CH Issue 2



IR1M and IRN1M Monnier

International Compressed Air Regulators

Description

The IR1M and IRN1M Monnier international compressed air regulators provide accurate pressure control for general purpose pneumatic systems.

Principal features:

- Good flow characteristics.
- Good regulation characteristics.
- Fast response.
- Dead tight shut-off on no-flow.
- For line, bracket or panel mounting.
- Internal and external high quality black anodised finish.

Available types:

IR1M	Self-relieving
IRN1M	Non-relieving

Optional extras

For further technical information regarding the following options see page 2:

- Tamper-proof cap.
- Type 21 mounting bracket.
- Mounting ring - Aluminium.
- Pressure gauges.

Sizes and pipe connections

1/4", 3/8" and 1/2" screwed BSP (BS 21-Rp).

Dimensions / weight (approximate) in mm and kg

A	B	C	D	E	F	Weight
90	117	64	46	18	30	0.45

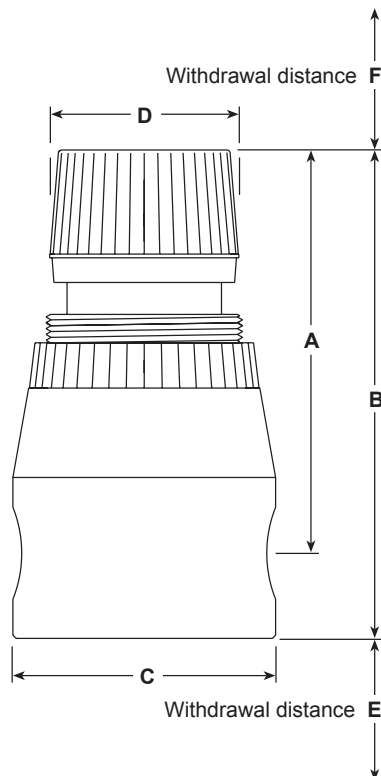

Spring range (operating pressure range)

All regulators can be adjusted to zero pressure, or above the figures shown. The operating range is marked on the unit.

Standard spring	0.5 - 10 bar g
Optional spring	0.2 - 3.5 bar g

Note: The IR range will be supplied with the standard spring unless an alternative option has been specified when placing an order.

Operating spring limits

Maximum working pressure	20 bar g
Maximum working temperature	70°C

Materials

No.	Part	Material
1	Body	Machined aluminium, anodised
2	Valve	Brass and nitrile 'O' ring
3	Diaphragm	Reinforced nitrile rubber

Optional extras

Tamper-proof cap

An aluminium tamper-proof cap can be fitted to prevent unauthorised pressure adjustment

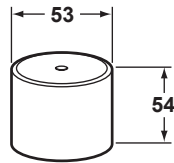

Dimensions (approximate) in mm

Type 21 mounting bracket

A zinc plated mild steel bracket can be attached to the regulator, using the plastic mounting ring supplied with the regulator. **Please note:** An aluminium mounting ring can be supplied, at extra cost, and must be specified at the time of order placement.

Dimensions (approximate) in millimetres

A	B	C	D	E
44	19	32	12	6

If the regulator is to be panel mounted a hole is required in the panel 48 mm diameter, and the panel thickness must not exceed 8 mm.

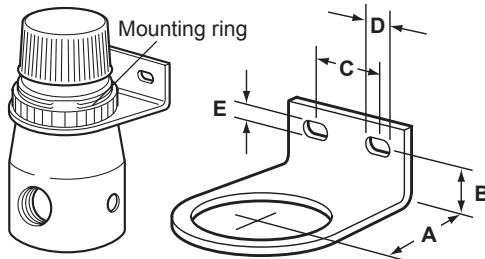

Pressure gauges

Available in two sizes, with 4 pressure ranges. The face is marked in both bar and psi. Please state, size and pressure range when placing an order.

Pressure ranges

0 to 2 bar	0 to 30 psi
0 to 7 bar	0 to 100 psi
0 to 11 bar	0 to 160 psi
0 to 21 bar	0 to 300 psi (50 mm size only)

Dimensions (approximate) in millimetres

Size	A	B	C	Size	A	B	C
40 mm	40	47	R ¹ / ₈ "	50 mm	49	45	R ¹ / ₈ "

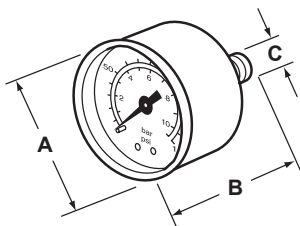

Pressure gauges for panel mounting

With chromium plated bezel available in two ranges, the face being marked in bar and psi as follows:-

Pressure ranges

0 to 2 bar	0 to 30 psi
0 to 7 bar	0 to 100 psi

Dimensions (approximate) in millimetres

A	B	C	D
53	56	48	R ¹ / ₈ "

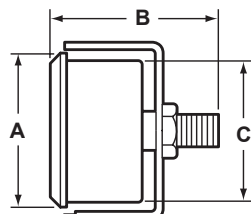
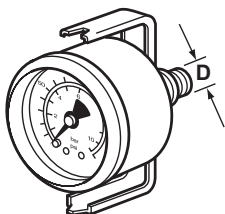

Principle of operation

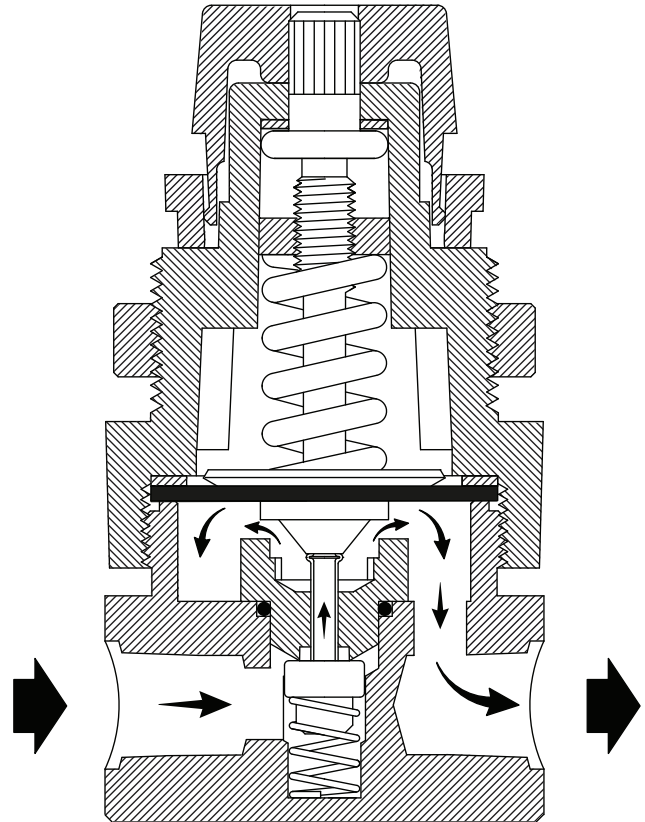

With system pressure on, the regulator poppet valve assembly is in the closed position when the adjusting knob is turned fully counter clockwise (no spring load). By turning the adjusting knob clockwise, the diaphragm / piston moves downward allowing flow to come in through the orifice created between the poppet assembly and seat. The control diaphragm / piston offsetting the load spring senses pressure downstream. Increasing downstream pressure causes the poppet assembly to move upward until the load of the spring and diaphragm / piston are balanced. The outlet pressure has now been reduced. If a valve is opened downstream, the increased demand for pressure creates a reduced pressure under the control diaphragm / piston. The poppet assembly moves downward due to the load of the control spring opening the seat area and air is allowed to meet the downstream pressure demand. Thus, the area of the opening meters the downstream flow.

Capacities

The full lift capacities for safety valve sizing purposes is 0.21 K_{VS}.

Performance selection (with primary pressure 10 bar)

For any specified primary filtration pressure, there is a maximum recommended air flowrate. Keeping within this, will ensure that the element performance maintains the stated high efficiency levels.

1/4"

- 1.6 bar g (23 psi g)
- 2.5 bar g (36 psi g)
- 4.0 bar g (58 psi g)
- 6.3 bar g (91 psi g)
- 8.0 bar g (116 psi g)

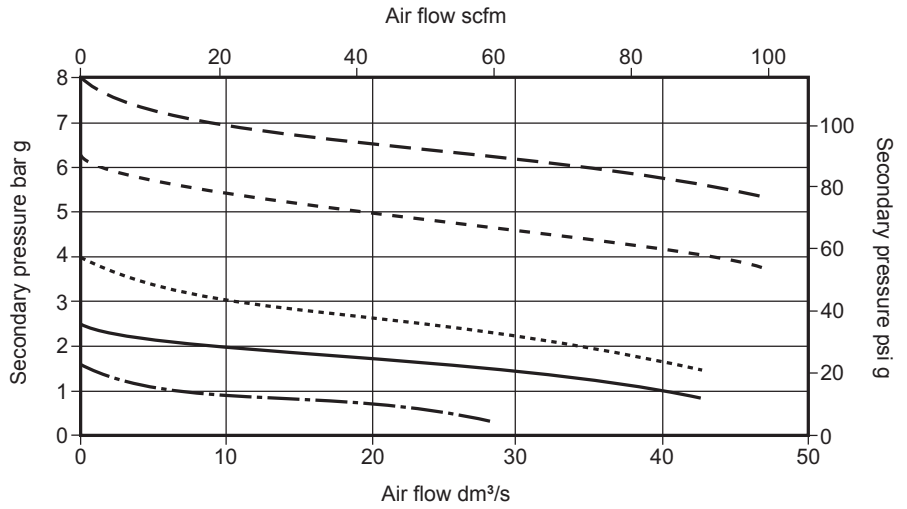

3/8"

- 1.6 bar g (23 psi g)
- 2.5 bar g (36 psi g)
- 4.0 bar g (58 psi g)
- 6.3 bar g (91 psi g)
- 8.0 bar g (116 psi g)

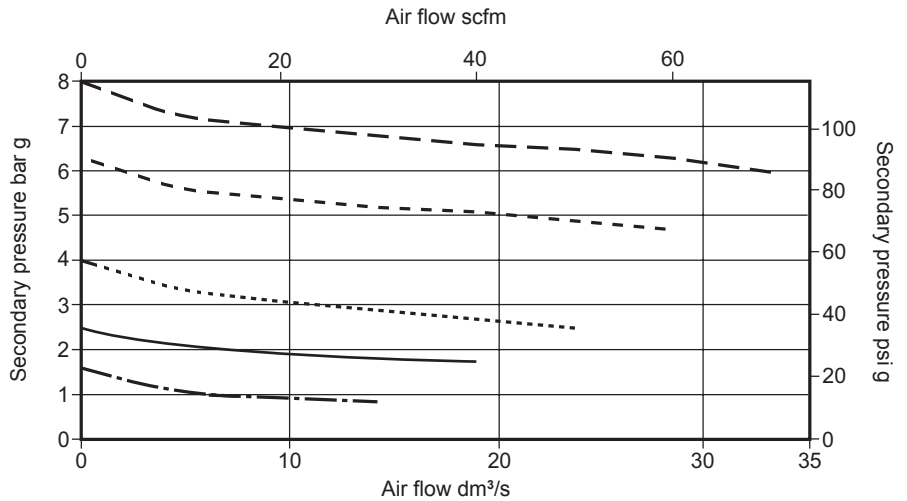

1/2"

- 1.6 bar g (23 psi g)
- 2.5 bar g (36 psi g)
- 4.0 bar g (58 psi g)
- 6.3 bar g (91 psi g)
- 8.0 bar g (116 psi g)

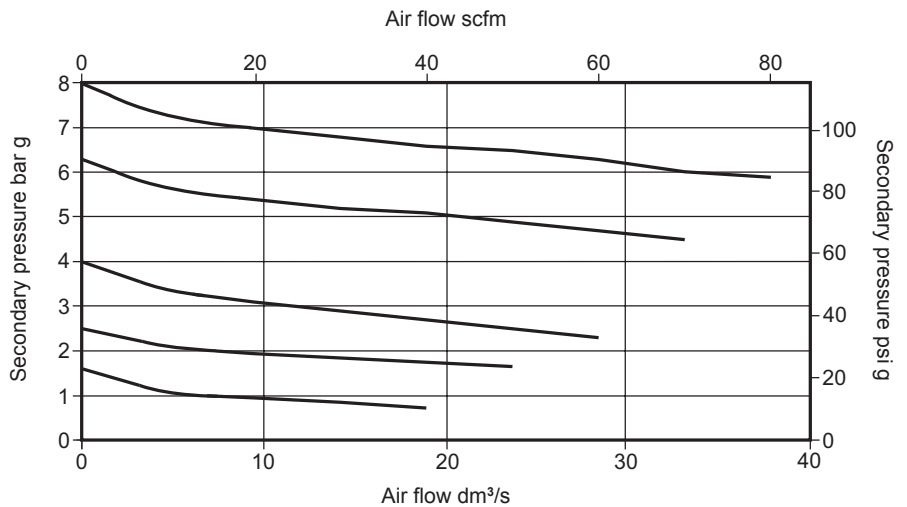

The graph utilises some typical values for secondary flow/pressure to demonstrate droop

$$\text{Droop} = \frac{\text{Pressure droop}}{\text{Set point}} @ \text{Relevant flowrate}$$

Spare parts

The spare parts available are detailed below. No other parts are supplied as spares.

Available spares

- Repair kit consisting of:**
- Diaphragm assembly
 - Poppet valve seat
 - Valve seat 'O' ring
 - Valve stem and poppet assembly
 - Poppet valve spring

How to order spares

Always order spares by using the description given in the column headed 'Available spares' and state the size and type of unit.

Example: 1 off repair kit for a ½" IR1M Monnier international compressed air regulator.

Safety information, installation and maintenance

For full details see the Installation and Maintenance Instructions (IM-P504-20) supplied with the product.

Installation note:

Fit into a horizontal pipeline with the air flow in the direction of the arrow, and bowl vertically downwards. A Monnier MF2M filter should be fitted upstream to prevent any contaminants reaching the regulator it is recommended that a pressure gauge is fitted to one of the ports to display the secondary pressure.

How to order

Example: 1 off IR1M Monnier self-relieving international compressed air regulator having a 0.5 to 10 bar spring assembly and female ½" screwed BSP (BS 21 - Rp) connections.

Note: If any optional extras are required, they must be clearly specified on the order.