



TI-P143-01
ST Issue 11

FT46 Stainless Steel Ball Float Steam Traps (DN15 to DN50)

FT46
4.5 bar - 21 bar
DN15, DN20 and DN25

DN15 shown

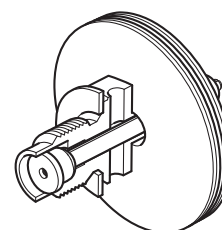
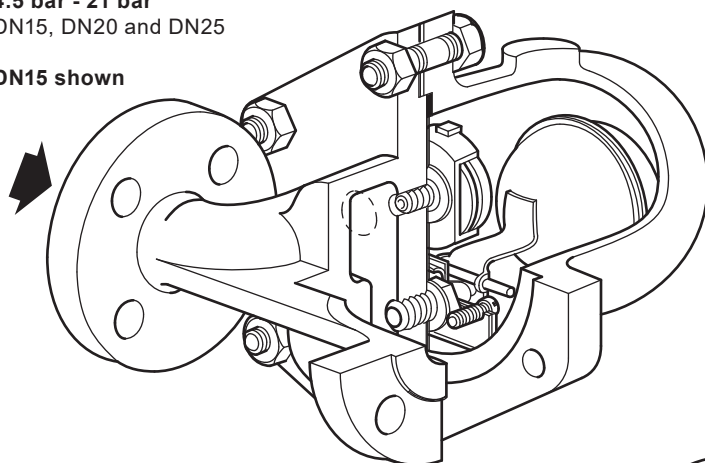

FT46
DN15 to DN50
32 bar

FT46-C
4.5-21 bar

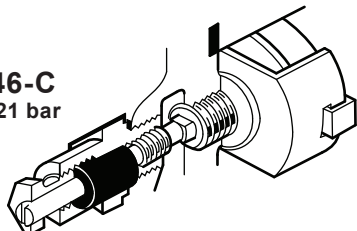

FT46
4.5, 10 and 21 bar
DN40 and DN50

DN50 shown

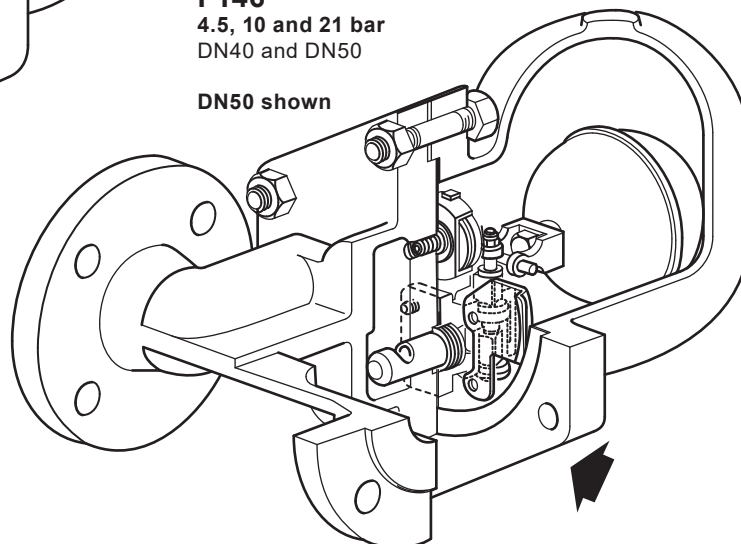

Description

The FT46 is an austenitic stainless steel bodied ball float steam trap having stainless steel working internals and automatic air venting facility. The body and cover castings are produced by a TÜV approved foundry. The trap is supplied with integrally flanged connections and can be maintained without disturbing the pipework. Flow direction for the horizontal trap is clearly illustrated above.

Air vent: The BP99/32 capsule which is used in the FT46 is suitable for use on 150 °C superheat @ 0 bar g. This value reduces with elevated pressure.

The bimetallic element is fitted as standard to the 32 bar variants to provide additional superheat resistance. It is also available on other variants on request. Please refer to the Pressure/temperature limits graph on page 2.

Standards: This product fully complies with the requirements of the European Pressure Equipment Directive and carries the  mark when so required.

Certification: This product is available with certification to EN 10204 3.1. **Note:** All certification/inspection requirements must be stated at the time of order placement.

Optional extras: A manually adjustable needle valve (designated 'C' on the nomenclature i.e. FT46-C) can be fitted to the trap. This option provides a **steam lock release (SLR)** feature in addition to the standard air vent.

Note: The SLR and bimetallic air vent cannot be used in conjunction with each other. Alternative arrangements may be available. For further information please consult Spirax Sarco.

The **top of the cover can be drilled and tapped 3/8" BSP or NPT** for the purpose of fitting a balance line if requested at the point of order.

The **bottom of the cover can be drilled and tapped 3/8" BSP or NPT** for the purpose of fitting a drain cock if requested at the point of order.

Sizes and pipe connections

DN15, DN20, DN25, DN40 and DN50.

Note: Flow direction when facing the body: - DN15 to DN25 is left to right. - DN40 and DN50 is right to left.

Standard flanges are EN 1092 PN40 with face-to-face dimensions in accordance with EN 26554 (Series 1).

On request - ASME (ANSI) B 16.5 Class 150 and 300 flanges are available with face-to-face dimensions in accordance with EN 26554 (Series 1).

Note: ASME (ANSI) flanges are supplied with tapped (UNC) holes for flange bolts.

Pressure / temperature limits

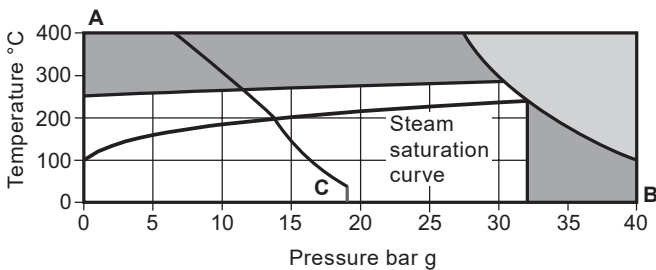

The product **must not** be used in this region.

This product should not be used in this region as damage to the air vent may occur.

A - B Flanged EN 1092 PN40 and ASME (ANSI) 300.

A - C Flanged ASME (ANSI) 150.

Note: The use of the bimetallic element extends the superheat resistance to in excess of 400 °C.

Body design conditions		PN40
PMA	Maximum allowable pressure	40 bar g @ 100 °C
TMA	Maximum allowable temperature	400 °C @ 27.4 bar g
Minimum allowable temperature		-10 °C
PMO	Maximum operating pressure for saturated steam service	32 bar g @ 239 °C
TMO	Maximum operating temperature	When fitted with a capsule 285 °C @ 30.3 bar g
		When fitted with a bimetallic air vent 400 °C @ 27.4 bar g
Minimum operating temperature		0 °C

Note: For lower operating temperatures consult Spirax Sarco

Δ PMX	Maximum differential pressure	Size	DN15 DN20 DN25	DN40 DN50
		FT46-4.5	4.5 bar	4.5 bar
FT46-10	10 bar	10 bar		
FT46-14	14 bar		-	
FT46-21	21 bar	21 bar	21 bar	
FT46-32	32 bar	32 bar	32 bar	

Designed for a maximum cold hydraulic test pressure: 60 bar g

Note: With internals fitted, test pressure must not exceed: 48 bar g

Caution: The trap in its complete operational form must not be subjected to a pressure greater than 48 bar otherwise damage to the internal mechanism may result.

Materials

No.	Part	Material	
1	Body	Austenitic stainless steel (316)	1.4408/CF8M
2	Cover studs	Austenitic stainless steel	A2.70
	Cover nuts	Austenitic stainless steel	A4
3	Cover gasket	Reinforced exfoliated graphite	
4	Cover	Austenitic stainless steel (316)	1.4408/CF8M
5	Valve seat	DN15, DN20 and DN25 Stainless steel	BS 970 431 S29
	Main valve assembly	DN40 and DN50 Stainless steel	BS 3146 Pt2 ANC2 BS 970 416 S37
6	Valve seat gasket	DN15, DN20 and DN25 Stainless steel	BS 1449 304 S11
	Main valve assembly gasket	DN40 and DN50 Reinforced exfoliated graphite	
7	Pivot frame assembly set screws	DN15, DN20 and DN25 Stainless steel	BS 4183 18/8
	Main valve assembly	Bolts Studs and nuts DN40 DN50	Stainless steel Stainless steel
8	Ball float and lever	Stainless steel	BS 1449 304 S16
9	Support frame	DN15, DN20 and DN25 Stainless steel	BS 1449 304 S16
10	Pivot frame	DN15, DN20 and DN25 Stainless steel	BS 1449 304 S16
11	Pivot pin	DN15, DN20 and DN25 Stainless steel	
12	Erosion deflector	Stainless steel	BS 970 431 S29
17	Air vent assembly for all pressure ratings	Stainless steel	
18	Air vent seat gasket	Stainless steel	BS 1449 409 S19
19	SLR assembly	Stainless steel	BS 970 303 S31
20	SLR gasket	Stainless steel	BS 1449 304 S11
21	SLR seal	Graphite	
26	Inlet plate	DN40 and DN50 only Stainless steel	BS 1449 304 S16

FT46

4.5 bar - 21 bar

DN15, DN20 and DN25

DN15 shown

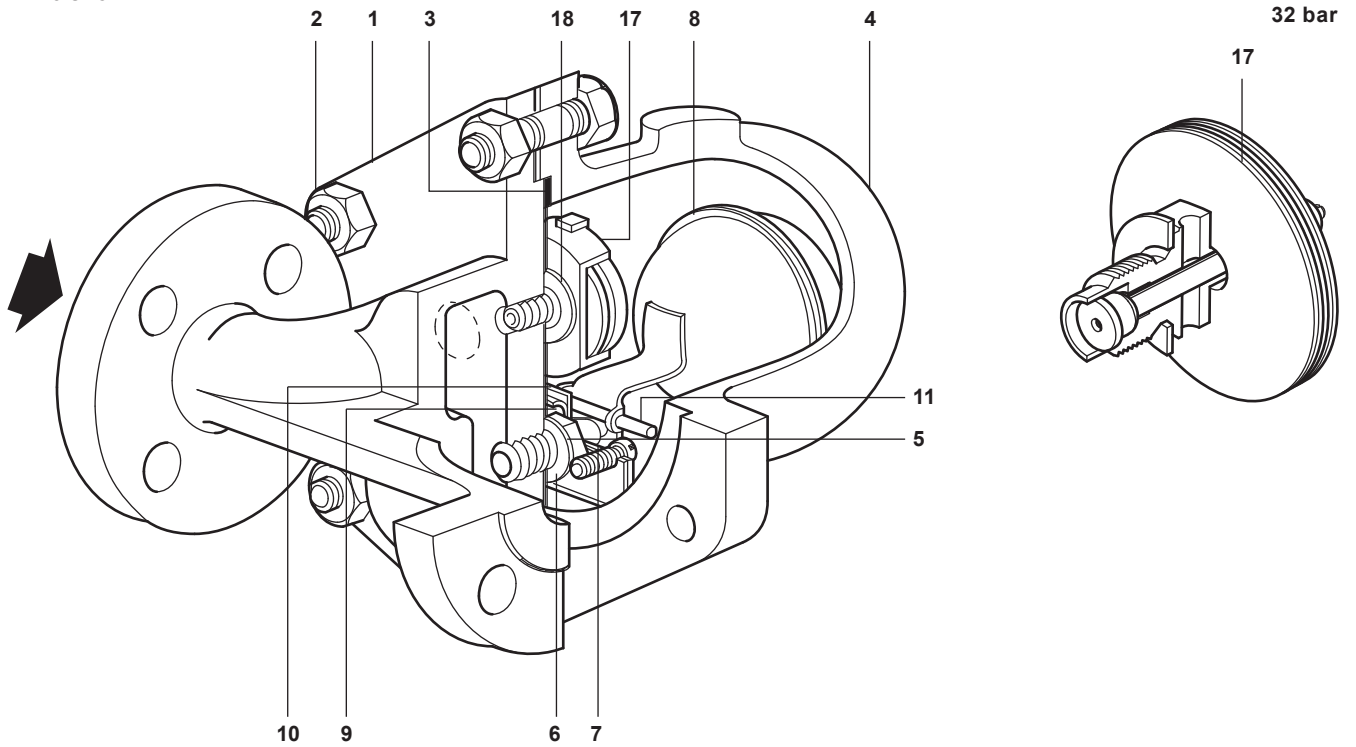

FT46-C

4.5-21 bar

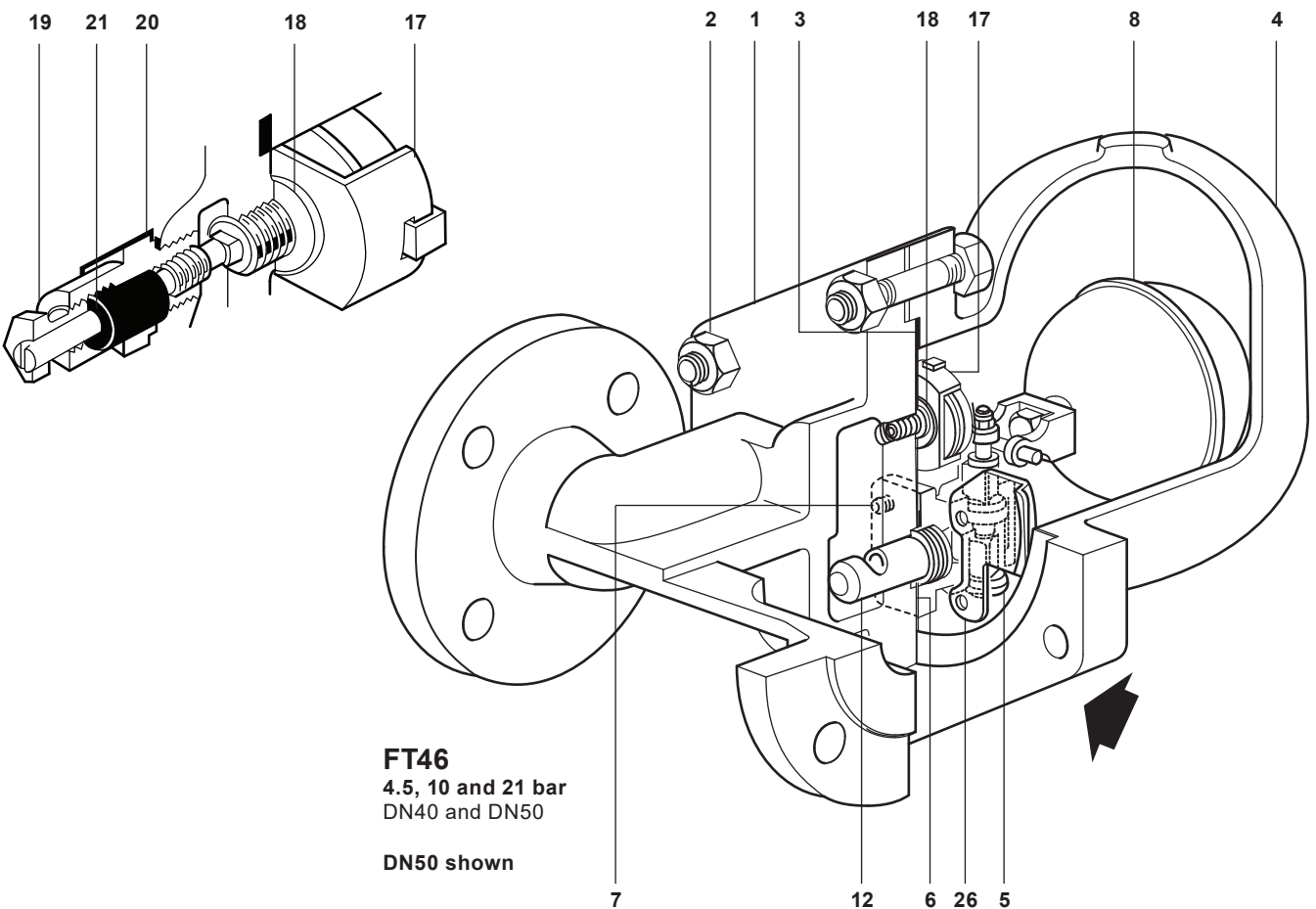

FT46
4.5, 10 and 21 bar
DN40 and DN50

DN50 shown

Capacities

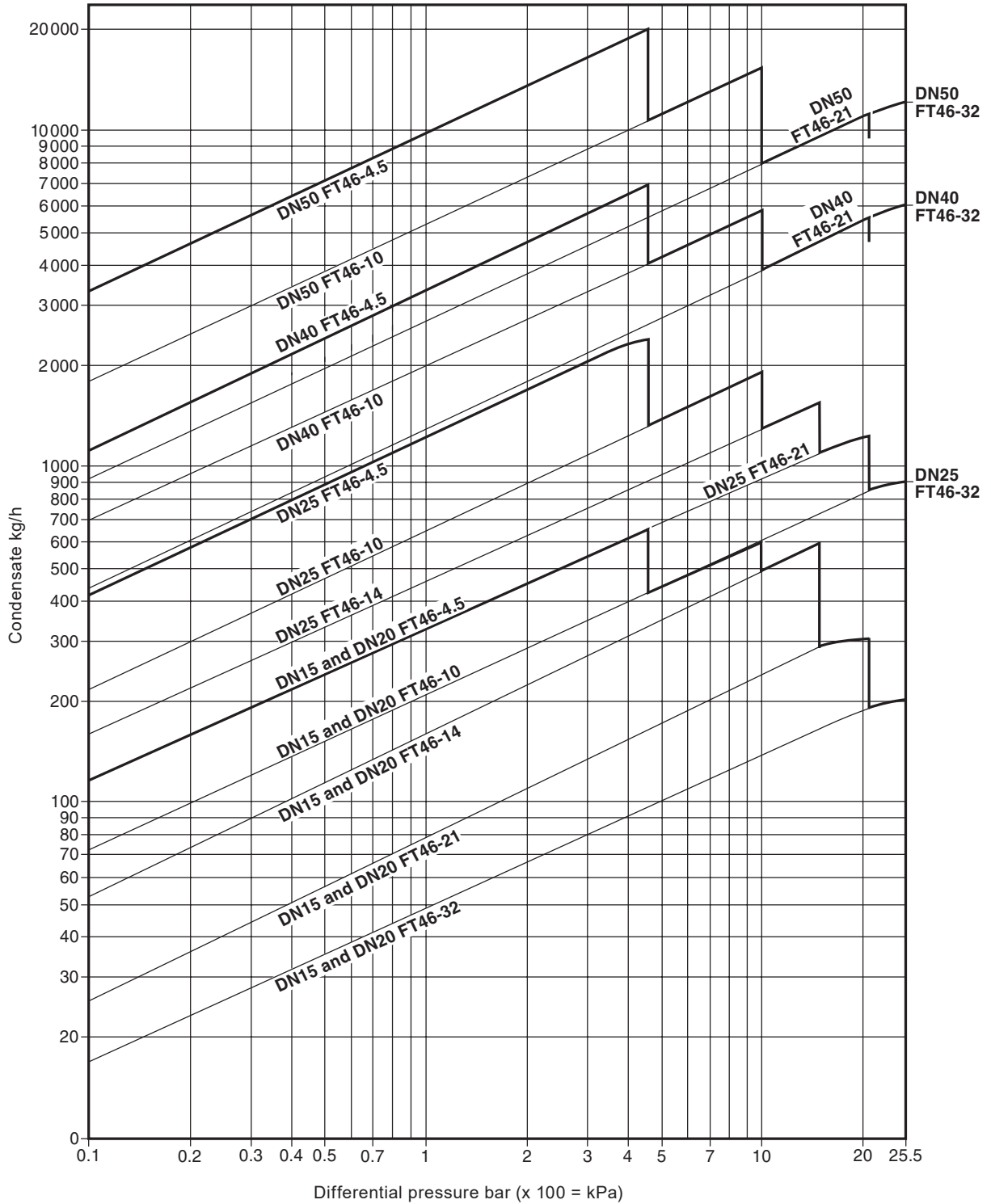

Additional cold water capacities from the thermostatic air vent under start-up conditions

Capacities shown above are based on condensate at saturation temperature. Under start-up conditions when the condensate is cold the internal thermostatic air vent will be open and provides additional capacity to the main valve. The following table gives the minimum additional cold water capacities from the air vent.

ΔP (bar)		0.5	1	2	3	4.5	7	10	14	21	32
		Minimum additional cold water capacity (kg/h)									
DN15 and DN20	up to 21 bar	450	600	780	1 040	1 140	1 350	1 530	1 750	2 300	-
	32 bar only	170	250	380	520	600	780	860	1 140	1 170	1 200
DN25, DN40 and DN50	up to 21 bar	460	680	900	1 080	1 300	1 600	1 980	2 050	2 600	-
	32 bar only	90	120	350	460	600	850	900	1 020	1 200	1 300

Dimensions/weights (approximate) in mm and kg

Size	A	B	C	D	E	F	Weight
DN15	150	80	80	215	120	155	10.8
DN20	150	80	80	225	120	165	10.8
DN25	160	115	85	276	170	215	15.0
DN40	230	130	115	326	200	200	33.0
DN50	230	141	123	332	200	225	43.0

Face-to-face dimensions in accordance with EN 26554 (Series 1)

FT46

DN15 and DN20

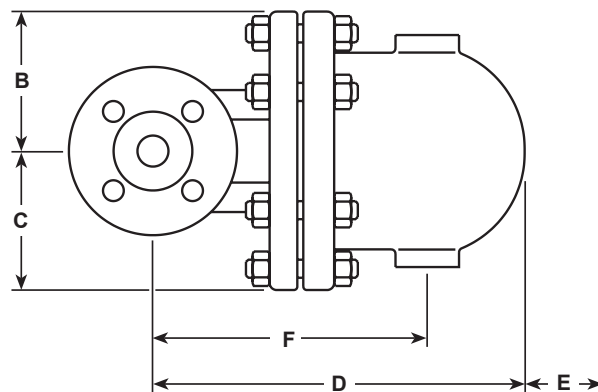
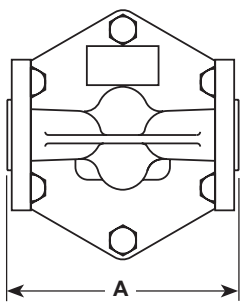

FT46

DN25, DN40 and DN50

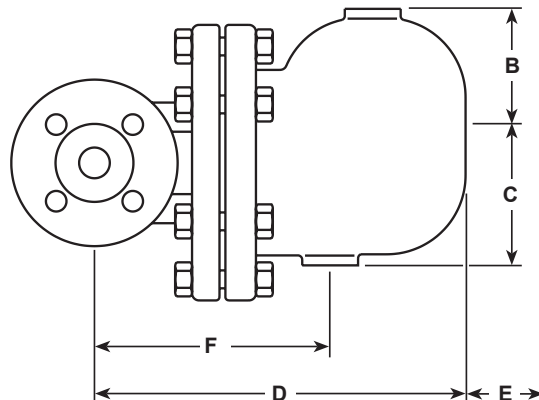

Safety information, installation and maintenance

For full details see the Installation and Maintenance Instructions (IM-S02-30) supplied with the product.

Installation note:

The FT46 must be installed with the direction of flow as indicated on the body, and with the float arm in a horizontal plane so that it rises and falls vertically.

Disposal

This product is recyclable. No ecological hazard is anticipated with the disposal of this product providing due care is taken.

How to order

Note: Although FT46 4.5 bar - 21 bar versions are fitted with a capsule air vent assembly as standard, they can be fitted with a bimetallic air vent assembly upon request.

Example: 1 off Spirax Sarco DN25 FT46-21 ball float steam trap, having an austenitic stainless steel body and cover with a bimetallic air vent assembly. Connections are to be flanged to EN1092 PN40.

Note: Although the FT46 32 bar is fitted with a bimetallic air vent assembly as standard, it can be fitted with a capsule air vent assembly and steam lock release feature upon request.

Example: 1 off Spirax Sarco DN25 FT46-21 ball float steam trap, having an austenitic stainless steel body and cover with a capsule air vent assembly. Connections are to be flanged to EN1092 PN40.

Spare parts

The spare parts available are shown in solid outline. Parts drawn in a grey line are not supplied as spares.

Available spares

Main valve assembly with float (DN15, DN20, and DN25)	5, 6, 7, 8, 9, 10, 11
Main valve assembly (DN40 and DN50)	5, 6, 7, 12, 26
Ball float (DN40 and DN50)	8
Air vent assembly	Bimetallic air vent assembly Capsule air vent assembly
	17, 18
Steam lock release and capsule air vent assembly (FT46-C)	17, 18, 19, 20, 21
Complete set of gaskets (packet of 3 sets)	3, 6, 18, 20, 21

Note: Item 12 (Erosion deflector) is only used in DN40 and DN50.



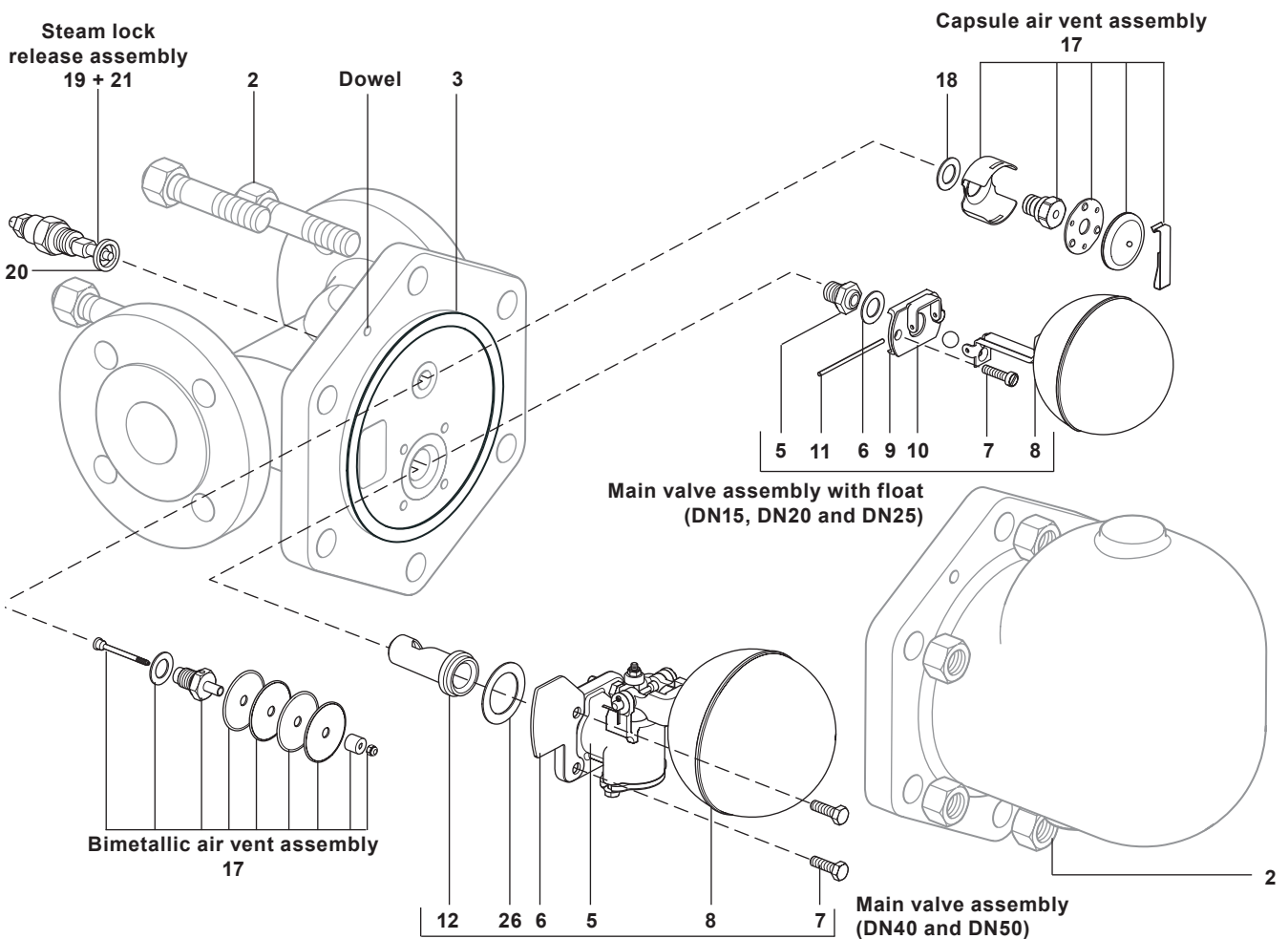

How to order spares

Always order spares by using the description given in the column headed 'Available spares' and state the size and type of trap, including pressure range.

Example: 1 - Capsule air vent assembly for a Spirax Sarco DN20 FT46-4.5 ball float steam trap.



Recommended tightening torques

Item	Size	or		N m	Item	Size	or		N m
									
2	DN15, 20 and 25	17 A/F	M10 x 60	19 - 22	7	DN15, 20 and 25		M5 x 20	2.5 - 2.8
	DN40	19 A/F	M16 x 85	60 - 66		DN40	10 A/F	M6 x 20	10 - 12
	DN50	24 A/F	M16 x 85	80 - 88		DN50	13 A/F	M8 x 20	20 - 24
5	DN15, 20 and 25	17 A/F		50 - 55	17				50 - 55