

SV81

Safety Valve

Installation and Maintenance Instructions

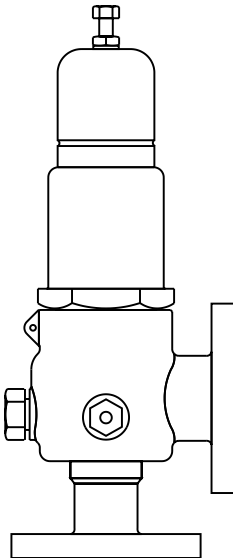

- 1. Safety information*
- 2. Product information*
- 3. Installation*
- 4. Damage prevention*
- 5. Commissioning*
- 6. Testing during use*
- 7. Maintenance*
- 8. Fault finding*

1. Safety information

Safe operation of these products can only be guaranteed if they are properly installed, commissioned, used and maintained by qualified personnel (see Section 1.11 on this document) in compliance with the operating instructions. General installation and safety instructions for pipeline and plant construction, as well as the proper use of tools and safety equipment must also be complied with.

1.1 Intended use

Referring to the Installation and Maintenance Instructions, name-plate and Technical Information Sheet, check that the product is suitable for the intended use/application. The product complies with the requirements of the European Pressure Equipment Directive 97/23/EC and fall within Category 4 for Group 1 and Group 2 Gases and carry the CE mark. For compatibility of all other fluids please consult Spirax Sarco.

- i) The product has been specifically designed for use on steam, air, inert industrial gases and liquids which are in Group 2 of the Pressure Equipment Directive. The products' use on other fluids may be possible but, if this is contemplated, Spirax Sarco should be contacted to confirm the suitability of the product for the application being considered.
- ii) Check material suitability, pressure and temperature and their maximum and minimum values.
- iii) Determine the correct installation situation and direction of fluid flow.
- iv) Spirax Sarco products are not intended to withstand external stresses that may be induced by any system to which they are fitted. It is the responsibility of the installer to consider these stresses and take adequate precautions to minimise them. Reaction forces must be considered and are the responsibility of the person installing the valve.
- v) Remove protective covers from all connections before installation.

1.2 Access

Ensure safe access and if necessary a safe working platform (suitably guarded) before attempting to work on the product. Arrange suitable lifting gear if required.

1.3 Lighting

Ensure adequate lighting, particularly where detailed or intricate work is required.

1.4 Hazardous liquids or gases in the pipeline

Consider what is in the pipeline or what may have been in the pipeline at some previous time. Consider: flammable materials, substances hazardous to health, extremes of temperature.

1.5 Hazardous environment around the product

Consider: explosion risk areas, lack of oxygen (e.g. tanks, pits), dangerous gases, extremes of temperature, hot surfaces, fire hazard (e.g. during welding), excessive noise, moving machinery.

1.6 The system

Consider the effect on the complete system of the work proposed. Will any proposed action (e.g. closing isolation valves, electrical isolation) put any other part of the system or any personnel at risk?

Dangers might include isolation of vents or protective devices or the rendering ineffective of controls or alarms. Ensure isolation valves are turned on and off in a gradual way to avoid system shocks.

1.7 Pressure systems

Ensure that any pressure is isolated and safely vented to atmospheric pressure. Do not assume that the system has depressurised even when the pressure gauge indicates zero.

1.8 Temperature

Allow time for temperature to normalise after isolation to avoid danger of burns.

1.9 Tools and consumables

Before starting work ensure that you have suitable tools and/or consumables available. Use only genuine Spirax Sarco replacement parts.

1.10 Protective clothing

Consider whether you and/or others in the vicinity require any protective clothing to protect against the hazards of, for example, chemicals, high/low temperature, radiation, noise, falling objects, and dangers to eyes and face.

1.11 Permits to work

All work must be carried out or be supervised by a suitably competent person. Installation and operating personnel should be trained in the correct use of the product according to the Installation and Maintenance Instructions.

Where a formal 'permit to work' system is in force it must be complied with. Where there is no such system, it is recommended that a responsible person should know what work is going on and, where necessary, arrange to have an assistant whose primary responsibility is safety.

Post 'warning notices' if necessary.

1.12 Handling

Manual handling of large and/or heavy products may present a risk of injury. Lifting, pushing, pulling, carrying or supporting a load by bodily force can cause injury particularly to the back. You are advised to assess the risks taking into account the task, the individual, the load and the working environment and use the appropriate handling method depending on the circumstances of the work being done.

Caution: Never lift the valve by the lifting lever.

1.13 Residual hazards

In normal use the external surface of the product may be very hot. If used at the maximum permitted operating conditions the surface temperature of some products may reach temperatures in excess of 1004°F (540°C).

Many products are not self-draining. Take due care when dismantling or removing the product from an installation (refer to 'Maintenance instructions').

1.14 Freezing

Provision must be made to protect products which are not self-draining against frost damage in environments where they may be exposed to temperatures below freezing point.

1.15 Safety information – Product specific

This product should not be dismantled without first releasing the compression on the adjustment spring.

Some variants of this valve contain Viton components. If the valve has been subjected to a temperature exceeding 392°F (200°C), material may generate toxic and corrosive hydrogen fluoride. Avoid skin contact and inhalation of any dust or fumes as this compound causes irritation to the eyes, nose, throat and lungs for several hours.

1.16 Disposal

The product is recyclable. No ecological hazard is anticipated with the disposal of this product providing due care is taken. EXCEPT;

Viton:

- Can be land filled, when in compliance with National and Local regulations.
- Can be incinerated, but a scrubber must be used to remove Hydrogen Fluoride, which is evolved from the product and with the compliance to National and Local regulations.
- Is insoluble in aquatic media.

1.17 Returning products

Customers and stockists are reminded that under EC Health, Safety and Environment Law, when returning products to Spirax Sarco they must provide information on any hazards and the precautions to be taken due to contamination residues or mechanical damage which may present a health, safety or environmental risk. This information must be provided in writing including Health and Safety data sheets relating to any substances identified as hazardous or potentially hazardous.

2. Product information

2.1 Description

The SV81 is a full-nozzle, safety valve suitable for gas, vapour, steam and liquid service in the process industries.

Available types

The body, bonnet, cap, nozzle, disc and spring are available in a variety of materials and selected to suit the chemical and physical characteristics of the specified process fluid.

Applications

The SV81 is designed to protect against overpressure in processes in the oil and gas, refining, chemical and petrochemical industries. Applications would typically include product pipelines, compressors, pumps, air receivers, unfired pressure vessels, and reactors. Fluids handled would include corrosive media, flammable, high temperature and high pressure. Please consult Spirax Sarco to establish material compatibility for these and other specific applications.

Standards and approvals

The SV81 is designed in accordance with API-RP-520 and ASME Boiler and Pressure Vessel Code, Section VIII. Seat tightness complies with API standard 527.

The valve is CE marked for compliance with European Pressure Equipment Directive 97/23/EC.

Certification

A certificate of conformity is supplied with each valve including valve set pressure and hydraulic test pressure. Material certification in accordance with EN 10204 3.1.B for all primary pressure containing parts is available upon request.

Note: For additional information see Technical Information Sheet TI-P254-01.

2.2 Sizes and pipe connections

Inlet			Outlet
1/2" (DN15)	x		1" (DN25)
3/4" (DN20)	x		1" (DN25)
1" (DN25)	x		1 1/2" (DN40)

Connection	Applicable standard
Screwed NPT	ANSI/ASME B 1.20.1
Screwed BSP	BS 21
Flanged ANSI RF or RTJ	ANSI B 16.5
Flanged	DIN
Socket weld	ANSI B 16.11
Butt weld	ANSI B 16.25

Inlet and outlet connections

Valve size	API orifice area		API letter	Actual flow area	
	in ²	mm ²		in ²	mm ²
1/2" x 1"	0.110	0.710	D	0.128	0.83
3/4" x 1"	0.110	0.710	D	0.128	0.83
1" x 1 1/2"	0.196	1.260	E	0.263	1.70

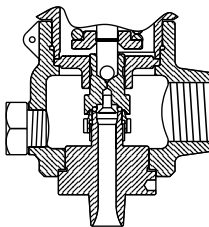

Fig. 1 Soft seat seal

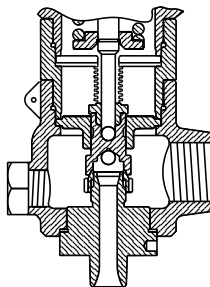

Fig. 2 Balanced bellows

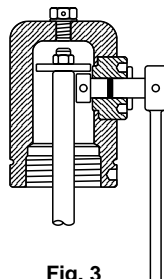

Fig. 3
Packed easing lever

2.3 Limiting conditions

Body design	ANSI 150, 300, 600 and 1500 (Refer to ANSI pressure/temperature ratings)		
Set pressure range	Minimum	7 psi g	(0.5 bar g)
	Maximum	3 000 psi g	(207.0 bar g)
Operating temperature range (Subject to selection of suitable materials)	Minimum	-320°F	(-196°C)
	Maximum	1 000°F	(540°C)
Maximum cold hydraulic test pressure	1.5 times design pressure		
Maximum constant backpressure	304.5 psi g 21 bar		
Maximum variable backpressure	10% of set pressure		

2.4 Dimensions and weights (approximate) in inches (mm) and lbs (kg)

Screwed ends (NPT or BSP)

Orifice	Inch In x Out	DN In x Out	Connection Inlet x Outlet	A ins (mm)	B ins (mm)	C* ins (mm)	Weight lbs (kg)
D	½ x 1	15 x 25	Male x Female	2.60(66.0)	2.32 (59)	8.90 (226)	14.1 (6.40)
	¾ x 1	20 x 25	Male x Female	2.64(67.0)			14.2 (6.43)
	½ x 1	15 x 25	Female x Female	2.26(57.5)			14.3 (6.49)
	¾ x 1	20 x 25	Female x Female	2.44(62.0)			14.2 (6.46)
E	1 x 1½	25 x 40	Male x Female	2.60(66.0)	2.32 (59)	8.90 (226)	14.3 (6.48)
	1 x 1½	25 x 40	Female x Female	2.28(57.9)			14.6 (6.60)

Flanged ends - Note: ANSI 1500 flanges available as RF or RTJ. All other flanges are RF.

Orifice	Inch In x Out	DN In x Out	Connection Inlet x Outlet	A ins (mm)	B ins (mm)	C* ins (mm)	Weight lbs (kg)
D	½ x 1	15 x 25	ANSI 150 x 150	3.15 (80)	3.21 (81.5)	8.90 (226)	17.7 (8.02)
	¾ x 1	20 x 25		3.15 (80)	3.21 (81.5)		18.1 (8.22)
E	1 x 1½	25 x 40		3.86 (98)	4.00(101.5)		19.0 (8.60)
D	½ x 1	15 x 25	ANSI 300 x 150	3.15 (80)	3.21 (81.5)	8.90 (226)	18.2 (8.25)
	¾ x 1	20 x 25		3.15 (80)	3.21 (81.5)		19.8 (8.96)
E	1 x 1½	25 x 40		3.86 (98)	4.00(101.5)		20.6 (9.34)
D	½ x 1	15 x 25	ANSI 600 x 150	3.90 (99)	3.21 (81.5)	8.90 (226)	18.6 (8.44)
	¾ x 1	20 x 25		4.53 (115)	3.21 (81.5)		20.2 (9.17)
E	1 x 1½	25 x 40		4.61 (117)	4.00(101.5)		21.2 (9.60)
D	½ x 1	15 x 25	ANSI 1500 x 300	3.90 (99)	3.21 (81.5)	8.90 (226)	22.8 (10.35)
	¾ x 1	20 x 25		4.53 (115)	3.21 (81.5)		24.3 (11.02)
E	1 x 1½	25 x 40		4.61 (117)	4.00(101.5)		27.2 (12.35)
D	½ x 1	15 x 25	DIN PN40 x PN16	3.15 (80)	3.21 (81.5)	8.90 (226)	19.2 (8.71)
	¾ x 1	20 x 25	DIN PN40 x PN40	3.15 (80)	3.21 (81.5)		20.0 (9.09)
E	1 x 1½	25 x 40		3.86 (98)	4.00(101.5)		20.9 (9.49)
D	½ x 1	15 x 25	DIN PN160 x PN40	3.90 (99)	3.21 (81.5)	8.90 (226)	20.0 (9.09)
	¾ x 1	20 x 25	AFNOR PN100 x PN40	4.53 (115)	3.21 (81.5)		21.6 (9.79)
E	1 x 1½	25 x 40	DIN PN160 x PN40	3.98 (101)	4.13(104.9)		23.7 (10.74)
D	½ x 1	15 x 25	DIN PN250 x PN40	3.90 (99)	3.21 (81.5)	8.90 (226)	22.3 (10.29)
E	1 x 1½	25 x 40		3.98 (101)	4.29(108.9)		25.8 (11.69)

Weld ends

Orifice	DN		Connection Inlet x Outlet	A		B		C* ins (mm)	Weight lbs (kg)
	In x Out	In x Out		ins (mm)	ins (mm)	ins (mm)	ins (mm)		
D	½ x 1	15 x 25	Butt weld	2.28 (57.9)	2.32 (59)	8.90 (226)		13.9 (6.30)	
	¾ x 1	20 x 25		2.28 (57.9)	2.32 (59)			13.9 (6.30)	
	1 x 1½	25 x 40		2.28 (57.9)	2.32 (59)			14.0 (6.33)	
E	½ x 1	15 x 25	Socket weld	2.02 (51.4)	2.32 (59)	8.90 (226)		13.8 (6.27)	
	¾ x 1	20 x 25		2.20 (55.9)	2.32 (59)			13.8 (6.27)	
	1 x 1½	25 x 40		2.02 (51.4)	2.32 (59)			13.7 (6.20)	

* **Note:** Apply the following to the sealed cap type valve with blanking plug:

Open lever dimension = 9.25" (235 mm).

Sealed cap with test gag = 9.41" (239 mm).

Open lever with test gag = 10.04" (255 mm)

For weight of lever type valve, add 1 lb (0.46 kg).

ANSI 1500 flanges available as RF or RTJ. All other flanges are RF.

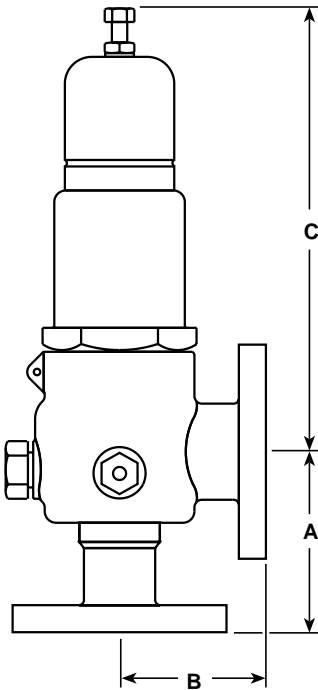

Fig. 4 SV81 Flanged

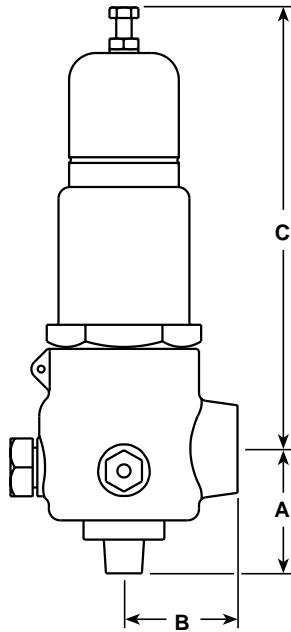

Fig. 5 SV81 Screwed, SW and BW

2.5 Materials

Item	Service/application				
	Standard	Low temperature (1)	Low temperature (2)	Corrosive (1)	Corrosive (2)
1 Body	Carbon steel ASTM A216 Gr. WCB	LT Carbon steel ASTM A352 Gr. LCB	Stainless steel ASTM A351 Gr. CF8M	Stainless steel ASTM A351 Gr. CF8M	Stainless steel ASTM A351 Gr. CF8M
2 Bonnet	Carbon steel ASTM A216 Gr. WCB	LT Carbon steel ASTM A352 Gr. LCB	Stainless steel ASTM A351 Gr. CF8M	Stainless steel ASTM A351 Gr. CF8M	Stainless steel ASTM A351 Gr. CF8M
3 Cap	Forged carbon steel ASTM A105	Forged carbon steel ASTM A105	Stainless steel ASTM A479 Gr. 316	Stainless steel ASTM A479 Gr. 316	Stainless steel ASTM A479 Gr. 316
4 Nozzle	Stainless steel ASTM A479 Gr. 316	Stainless steel ASTM A479 Gr. 316	Stainless steel ASTM A479 Gr. 316	Stainless steel ASTM A479 Gr. 316	Monel* M400 B164 (UNS N04400)
5 Disc	Stainless steel ASTM A479 Gr. 316	Stainless steel ASTM A479 Gr. 316	Stainless steel ASTM A479 Gr. 316	Stainless steel ASTM A479 Gr. 316	Monel* M400 B164 (UNS N04400)
6 Spring	Carbon steel ASTM A231	Stainless steel ASTM A313 Gr. 302	Stainless steel ASTM A313 Gr. 302	Stainless steel ASTM A313 Gr. 302	Stainless steel ASTM A313 Gr. 302
7 Spring plate	Stainless steel ASTM A479 Gr. 316	Stainless steel ASTM A479 Gr. 316	Stainless steel ASTM A479 Gr. 316	Stainless steel ASTM A479 Gr. 316	Stainless steel ASTM A479 Gr. 316
8 Spindle	Stainless steel ASTM A479 Gr. 316	Stainless steel ASTM A479 Gr. 316	Stainless steel ASTM A479 Gr. 316	Stainless steel ASTM A479 Gr. 316	Stainless steel ASTM A479 Gr. 316
9 Skirt	Stainless steel ASTM A479 Gr. 316	Stainless steel ASTM A479 Gr. 316	Stainless steel ASTM A479 Gr. 316	Stainless steel ASTM A479 Gr. 316	Stainless steel ASTM A479 Gr. 316
10 Wire ring	Stainless steel BS 2056 316 S42	Stainless steel BS 2056 316 S42	Stainless steel BS 2056 316 S42	Stainless steel BS 2056 316 S42	Stainless steel BS 2056 316 S42
11 Valve guide	Stainless steel ASTM A479 Gr. 316	Stainless steel ASTM A479 Gr. 316	Stainless steel ASTM A479 Gr. 316	Stainless steel ASTM A479 Gr. 316	Stainless steel ASTM A479 Gr. 316
12 Adjuster	Stainless steel ASTM A479 Gr. 410	Stainless steel ASTM A479 Gr. 410	Stainless steel ASTM A479 Gr. 410	Stainless steel ASTM A479 Gr. 410	Stainless steel ASTM A479 Gr. 410
13 Lock-nut	Stainless steel ASTM A479 Gr. 316	Stainless steel ASTM A479 Gr. 316	Stainless steel ASTM A479 Gr. 316	Stainless steel ASTM A479 Gr. 316	Stainless steel ASTM A479 Gr. 316
14 Ball	Stainless steel AISI 316L	Stainless steel AISI 316L	Stainless steel AISI 316L	Stainless steel AISI 316L	Stainless steel AISI 316L
15 Blowdown ring	Stainless steel AISI 303	Stainless steel AISI 303	Stainless steel AISI 303	Stainless steel AISI 303	Stainless steel AISI 303
16 Locking plug	Stainless steel ASTM A479 Gr. 316	Stainless steel ASTM A479 Gr. 316	Stainless steel ASTM A479 Gr. 316	Stainless steel ASTM A479 Gr. 316	Stainless steel ASTM A479 Gr. 316
17 Locking pin	Stainless steel ASTM A479 Gr. 316	Stainless steel ASTM A479 Gr. 316	Stainless steel ASTM A479 Gr. 316	Stainless steel ASTM A479 Gr. 316	Stainless steel ASTM A479 Gr. 316
18 Lever	SG iron DIN 1693 GGG 40.3	SG iron DIN 1693 GGG 40.3	SG iron DIN 1693 GGG 40.3	SG iron DIN 1693 GGG 40.3	SG iron DIN 1693 GGG 40.3
19 Spirol pin	Stainless steel AISI 302/304	Stainless steel AISI 302/304	Stainless steel AISI 302/304	Stainless steel AISI 302/304	Stainless steel AISI 302/304
20 Drain plug	Forged carbon steel ASTM A105	Forged carbon steel ASTM A105	Stainless steel ASTM A479 Gr. 316	Stainless steel ASTM A479 Gr. 316	Stainless steel ASTM A479 Gr. 316
21 Gasket	Klinger SLS Semi rigid graphite	Klinger SLS Semi rigid graphite	Klinger SLS Semi rigid graphite	Klinger SLS Semi rigid graphite	Klinger SLS Semi rigid graphite
22 Gasket	Klinger SLS Semi rigid graphite	Klinger SLS Semi rigid graphite	Klinger SLS Semi rigid graphite	Klinger SLS Semi rigid graphite	Klinger SLS Semi rigid graphite
23					
24 Gaskets	Klinger C-4430	Klinger C-4430	Klinger C-4430	Klinger C-4430	Klinger C-4430
25					
** 26 Test gag screw	Zinc plated steel BS 3692 Gr. 8.8	Zinc plated steel BS 3692 Gr. 8.8	Zinc plated steel BS 3692 Gr. 8.8	Zinc plated steel BS 3692 Gr. 8.8	Zinc plated steel BS 3692 Gr. 8.8
** 27 Gag lock-nut	Zinc plated steel BS 3692 Gr. 8	Zinc plated steel BS 3692 Gr. 8	Zinc plated steel BS 3692 Gr. 8	Zinc plated steel BS 3692 Gr. 8	Zinc plated steel BS 3692 Gr. 8
28 Hex. head screw	Stainless steel ISO 3506 Gr. A4-70	Stainless steel ISO 3506 Gr. A4-70	Stainless steel ISO 3506 Gr. A4-70	Stainless steel ISO 3506 Gr. A4-70	Stainless steel ISO 3506 Gr. A4-70
** 29 Name-plate	Stainless steel	Stainless steel	Stainless steel	Stainless steel	Stainless steel
** 30 Sealing wire	Stainless steel	Stainless steel	Stainless steel	Stainless steel	Stainless steel

* Note: Corrosive construction is also available with the following nozzle and disc materials:

- Hastelloy B3 (UNS N10675)

- Hastelloy C : ASTM B574 (UNS N10276)

** Not shown

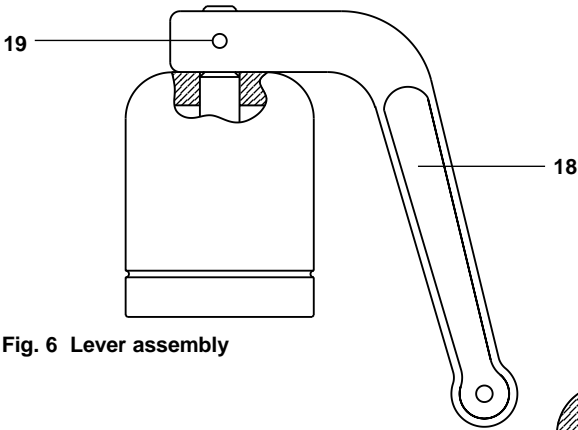

Fig. 6 Lever assembly

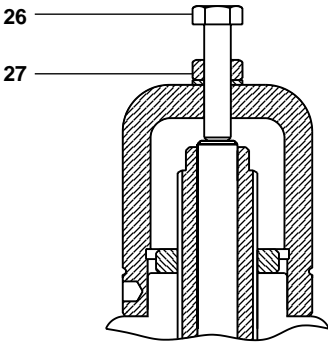

Fig. 7 Cap (with test gag fitted)

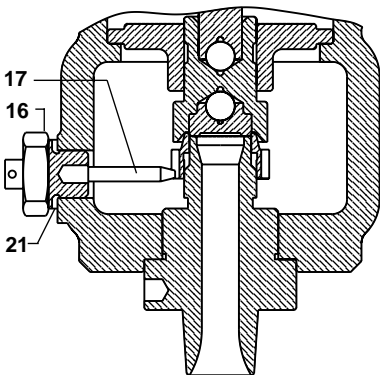

Fig. 8 Blowdown assembly

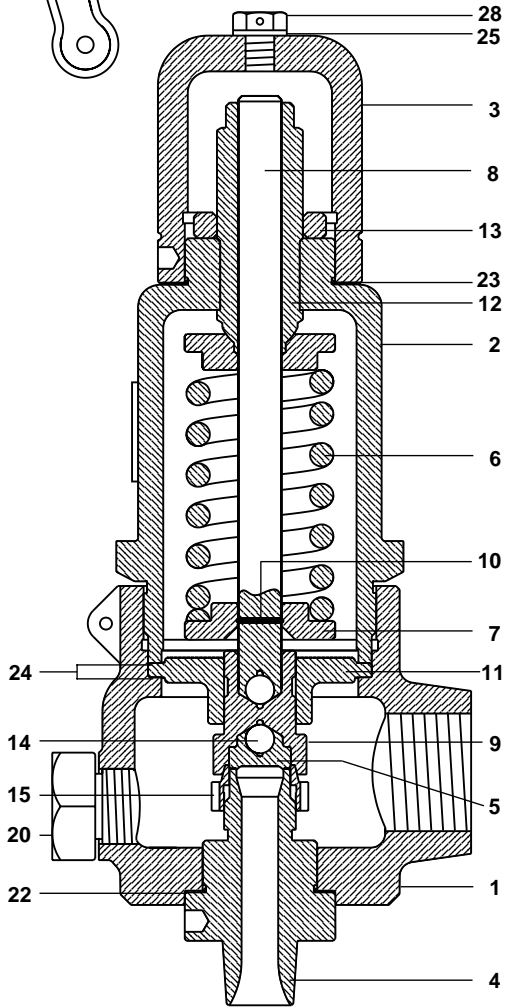

Fig. 9 SV81

2.6 How to specify the SV81

Model	SV81			SV81
Body/Bonnet/ Cap material		Body	Bonnet	Cap
	1 =	LCB	LCB	A105
	4 =	WCB	WCB	A105
	6 =	CF8M	CF8M	AISI 316
	M =	Monel 400	Monel 400	Monel 400
	C =	Hastelloy C	Hastelloy C	Hastelloy C
Inlet/Orifice/ Outlet		Inlet	Orifice	Outlet
	4 =	½"	D	1"
	6 =	¾"	D	1"
	8 =	1"	E	1½"
Inlet and outlet connections (Note: Certain combinations may not be available).		Inlet	Outlet	
	01 =	ANSI 150 RF	01 =	ANSI 150 RF
	03 =	ANSI 300 RF	03 =	ANSI 300 RF
	06 =	ANSI 600 RF	04 =	PN40
	15 =	ANSI 1500 RF or RTJ (please specify)	77 =	Socket weld
	37 =	BSP male	47 =	BSP female
	47 =	BSP female	48 =	NPT female
	38 =	NPT male		
	48 =	NPT female		
	04 =	PN40		
	10 =	PN100 (DN20 only)		
	16 =	PN160 (DN15 and DN25 only)		
	25 =	PN250		
77 =	Socket weld			
88 =	Butt weld			
Cap type	A =	Plain lever with test gag		
	B =	Gas tight cap with test gag		
	C =	Packed lever with test gag		

	Nozzle	Disc		
Nozzle/disc material	A =	AISI 316	17-4 PH Stainless steel (steam)	
	C =	Hastelloy C	Hastelloy C	
	M =	Monel 400	Monel 400	
	S =	AISI 316	AISI 316	
	L =	316 + Stellite	316 + Stellite	S
	T =	AISI 316	316 + Stellite	
	B =	Hastelloy B	Hastelloy B	
	V =	AISI 316	AISI 316 + Viton	
	N =	AISI 316	AISI 316 + Nitrile	
	K =	AISI 316	AISI 316 + Kalrez	
Bellows	0 =	None		0
	1 =	316 + Ti		
Spring material	A =	Carbon steel		
	T =	Tungsten		
	I =	Stainless steel		A
	X =	Inconel X750		

Selection example:

3. Installation

Note: Before actioning any installation observe the 'Safety information' in Section 1.

Referring to the Installation and Maintenance Instructions, name-plate and Technical Information Sheet, check that the product is suitable for the intended installation. Normally, the valve will be supplied set at the required pressure and sealed.

National standards and local regulations require that the setting of the valve should only be carried out by an authorised/competent person.

Spirax Sarco accepts no responsibility for any valve that has been reset by unauthorised persons.

- 3.1** Ensure that the pipework installation is suitable for the valve.
- 3.2** Ensure that the vessel and pipework are completely free of any foreign matter that may otherwise pass to the valve seat and cause damage, leading to seat leakage. This must be carried out before installing the safety valve.
- 3.3** Remove all packaging and protective flange covers taking care not to allow dirt, dust or other material into the valve.
- 3.4** Visually inspect the valve for any apparent damage. Ensure that all wire and seals are intact.
- 3.5** The SV81 safety valve is factory fitted with a test gag which, in addition to providing a means of pressure testing the piping system when the valve is installed, also prevents damage to the nozzle and disc seating faces during transit. The test gag must be removed for correct operation of the valve and, in the case of sealed cap type valves, replaced with the blanking plug provided.
- 3.6 Inlet piping** - The SV81 safety valve should be installed in a vertical upright position. The inlet piping to the valve should be short and direct from the vessel or equipment being protected. The connection to the vessel should be straight. Sharp corners should be avoided. Should this not be practical, the inlet should be flared out at least one additional pipe diameter.
The pressure drop from the vessel to the safety valve must be less than 3% of the valve set pressure when the valve is flowing. The inlet pipe must not be smaller than the inlet diameter of the valve.
- 3.7 Outlet piping** - Discharge lines from the SV81 shall be at least the same size as the valve outlet and as short and direct as possible. Discharge lines shall prevent condensate from collecting in the discharge side of the valve body and must be directed to a safe discharge area. Care should be taken to ensure thermal expansion of piping and support does not produce strains in the valve. Spring supports are recommended where this may be the case.
- 3.8** Safety valves should be mounted in such a manner as to provide adequate access to the valve.
- 3.9** Always ensure that the backpressure does not exceed 10% of the valve set pressure.
- 3.10** Once the valve has been fitted check that there are no leaks from either the inlet or outlet connections.

4. Damage prevention

Excessive pressure loss at the inlet of a safety valve when it operates will cause extremely rapid opening and closing of the valve, observed as chattering or hammering. This may result in reduced capacity as well as damage to seating faces and the other parts of the valve. When normal pressure is restored it is possible that the valve will leak.

Solution

Valve should be fitted 8-10 pipe diameters downstream of converging or diverging fittings or bends. (Fig. 10). Inlet branches should be as Fig. 11.

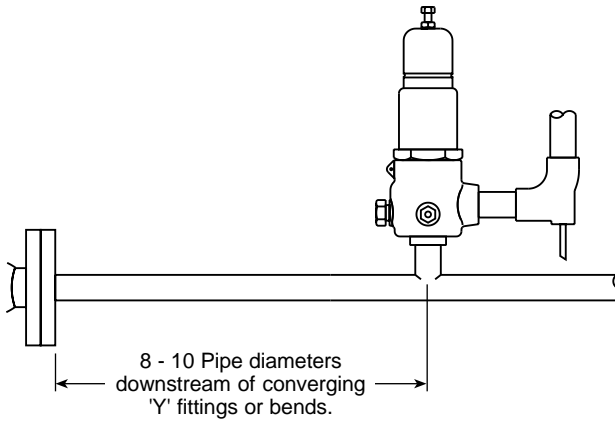

Fig. 10 Recommended location of installation

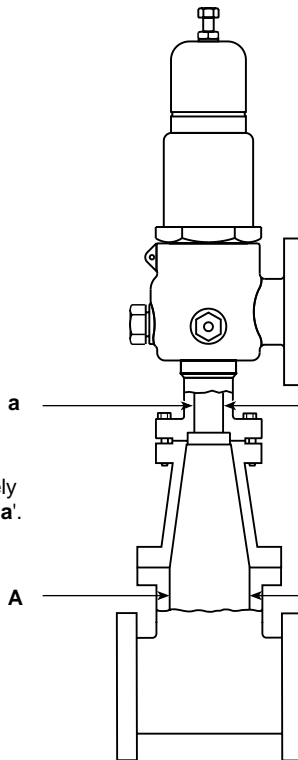

Fig. 11
Inlet area 'A' approximately
twice that of inlet of area 'a'.

5. Commissioning

After installation or maintenance ensure that the system is fully functioning. Carry out tests on any alarms or protective devices

Test the set pressure of the valve by slowly raising the system pressure. Ensure that the valve operates correctly at its specified set pressure as indicated on the name-plate.

Reduce the system pressure to the normal operating pressure and check that the safety valve reseats.

6. Testing during use

The SV81 safety valve is factory fitted with a test gag.

Where it is intended to pressure test the piping system above the set pressure of the safety valve, the test gag should left in place until such tests are completed and then immediately removed and, in the case of sealed cap type valves, replaced by the blanking plug provided.

7. Maintenance

SV81 Safety valves are 100% tested and then sealed to prevent unauthorised adjustment or repair. Valves should be inspected regularly to assure continued safe operation and long service life. A visual inspection is recommended at two-month intervals while in service, followed by a complete pressure test at least once a year. The frequency of such tests will vary according to operating conditions.

The SV81 can be operated manually by means of the test lever (where fitted) and when the system pressure is at least 75% of the set pressure, or the system pressure may be carefully increased until the valve operates. Never attempt to stop leakage by compressing the spring or gagging the valve!

For resetting, adjustments or repairs contact Spirax Sarco for the name of competent, authorised personnel who are familiar with the servicing of these safety valves.

8. *Fault finding*

Caution! Removal of the seal wires in an attempt to adjust and/or repair this product by unauthorised or non-qualified persons voids the product guarantee and may cause damage to equipment and serious injury or death.

Problem	Possible cause	Corrective action
Valve does not open at set pressure	Incorrect set pressure	Consult supplier/manufacturer
	Test gag fitted	Remove test gag
	Protective flange cover not removed	Remove protective flange cover
	Backpressure too high	Verify the maximum value of backpressure and/or consult supplier/manufacturer
Simmer/warn	Pressure gauge incorrect	Recalibrate or replace gauge.
	Blowdown ring positioned too low	Consult supplier/manufacturer
Valve leaking and/or exhibits erratic popping action	Line vibrations	Eliminate any vibrations at the valve
	Damaged seat	Consult supplier/manufacturer
	Misalignment of parts	Consult supplier/manufacturer
	Stress distortions by thermal changes due to fixed discharge	Correct source of distortion by proper support
	Blowdown ring too high	Consult supplier/manufacturer
Hang up, will not reseat/ blows off continuously	High backpressure	Check process conditions/consult manufacturer
	Foreign material in seating or guide area	Consult supplier/manufacturer
	Spring broken or relaxed	Consult supplier/manufacturer
Excessive blowdown	Blowdown ring positioned too high	Consult supplier/manufacturer
	High backpressure	Decrease backpressure by increasing outlet pipe discharge area
Chatter/short blowdown	Excessive inlet piping pressure loss	Reduce inlet pressure drop to less than 10% of set pressure. Change inlet pipe size.
	Incorrect valve size for application	Review process conditions and valve sizing. Consult supplier/manufacturer
	Gaskets for inlet/outlet flanges too small	Change the gasket
	Variable backpressure exceeds 10% of set pressure	Consult supplier/manufacturer
	Blowdown ring positioned too high	Consult supplier/manufacturer
Valve does not achieve required lift	Foreign matter trapped between disc and upper adjustment ring	Consult supplier/manufacturer
	Valve is oversized	Consult supplier/manufacturer
Valve cannot be lifted manually	Operating pressure is less than 75% of set pressure	Increase the operating pressure to 75% of set pressure or higher

