

PA420**4-20 mA Loop Powered Level Pre-amplifier**Installation and Maintenance Instructions

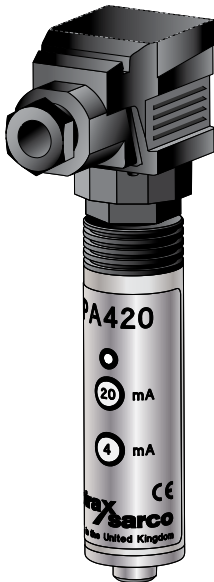

1. Safety information
2. General product information
3. Installation
4. Wiring
5. Commissioning
6. Maintenance
7. Fault finding
8. Technical data



1. Safety information

Safe operation of the product depends on it being properly installed, commissioned and maintained by a qualified person (see Section 1.11) in compliance with the operating instructions.

It is essential to comply with general installation and safety instructions for pipeline and plant construction, as well as to make proper use of tools and safety equipment.

The product is designed and constructed to withstand the forces encountered during normal use. Use of the product for any other purpose, or failure to install the product in accordance with these Installation and Maintenance Instructions, could cause damage to the product, will invalidate the CE marking, and may cause injury or fatality to personnel.

Additional Safety Notes:

Level control and level limiting/alarm products in steam boilers

Products/systems must be selected, installed, operated, and tested in accordance with:

- Local or National standards and regulations.
- Guidance Notes, (Health and Safety Executive BG01 and INDG436 in the UK).
- The requirements of Approvals Authorities.
- Boiler inspection bodies.
- Boiler manufacturer's specifications.

Two independent low water limiting/alarm systems must be installed on steam boilers. Level probes must be installed in separate protection tubes/chambers, with sufficient clearance between the tips, and earth.

Each probe must be connected to an independent controller. The alarm relays must isolate the boiler heat supply at low alarm status.

A high water alarm may be part of the water level control, or a separate system. An independent high water alarm system must be fitted if it is considered a safety requirement. In this case, the relays must simultaneously isolate the feedwater supply and the boiler heat supply at high alarm status. All boiler water limiters/alarms require regular functional testing.

A suitable water treatment regime must be used to ensure continuous safe and correct operation of the control and limiter/alarm systems. Consult the above authorities and a competent water treatment company.

Warning

This product complies with Electromagnetic Compatibility Directive 2004 / 108 / EC and all its requirements.

This product is suitable for Heavy Industrial Environments. A fully detailed EMC assessment has been made and has the reference number UK Supply BH PA420.

The product may be exposed to interference above the limits of Heavy Industrial Immunity if:

- The product or its wiring is located near a radio transmitter.
- Excessive electrical noise occurs on the mains supply. Power line protectors (ac) should be installed if mains supply noise is likely. Protectors can combine filtering, suppression, surge and spike arrestors.
- Cellular telephones and mobile radios may cause interference if used within approximately 1 metre (39") of the product or its wiring. The actual separation distance necessary will vary according to the surroundings of the installation and the power of the transmitter.

If this product is not used in the manner specified by this IMI, then the protection provided may be impaired.

1.1 Intended use

- i) Check that the product is suitable for use with the intended fluid.
- ii) Check material suitability, pressure and temperature and their maximum and minimum values. If the maximum operating limits of the product are lower than those of the system in which it is being fitted, or if malfunction of the product could result in a dangerous overpressure or overtemperature occurrence, ensure a safety device is included in the system to prevent such over-limit situations.
- iii) Determine the correct installation situation and direction of fluid flow.
- iv) Spirax Sarco products are not intended to withstand external stresses that may be induced by any system to which they are fitted. It is the responsibility of the installer to consider these stresses and take adequate precautions to minimise them.
- v) Remove protection covers from all connections before installation.

Safe operation of the product can only be guaranteed if they are properly installed, commissioned, used and maintained by qualified personnel (see Section 1.11 on this document) in compliance with the operating instructions. General installation and safety instructions for pipeline and plant construction, as well as the proper use of tools and safety equipment must also be complied with.

1.2 Access

Ensure safe access and if necessary a safe working platform (suitably guarded) before attempting to work on the product. Arrange suitable lifting gear if required.

1.3 Lighting

Ensure adequate lighting, particularly where detailed or intricate work is required.

1.4 Hazardous liquids or gases in the pipeline

Consider what is in the pipeline or what may have been in the pipeline at some previous time. Consider: flammable materials, substances hazardous to health, extremes of temperature.

1.5 Hazardous environment around the product

Consider: explosion risk areas, lack of oxygen (e.g. tanks, pits), dangerous gases, extremes of temperature, hot surfaces, fire hazard (e.g. during welding), excessive noise, moving machinery.

1.6 The system

Consider the effect on the complete system of the work proposed. Will any proposed action (e.g. closing isolation valves, electrical isolation) put any other part of the system or any personnel at risk?

Dangers might include isolation of vents or protective devices or the rendering ineffective of controls or alarms. Ensure isolation valves are turned on and off in a gradual way to avoid system shocks.

1.7 Pressure systems

Ensure that any pressure is isolated and safely vented to atmospheric pressure. Consider double isolation (double block and bleed) and the locking or labelling of closed valves. Do not assume that the system has depressurised even when the pressure gauge indicates zero.

1.8 Temperature

Allow time for temperature to normalise after isolation to avoid danger of burns.

1.9 Tools and consumables

Before starting work ensure that you have suitable tools and/or consumables available. Use only genuine Spirax Sarco replacement parts.

1.10 Protective clothing

Consider whether you and/or others in the vicinity require any protective clothing to protect against the hazards of, for example, chemicals, high/low temperature, radiation, noise, falling objects, and dangers to eyes and face.

1.11 Permits to work

All work must be carried out or be supervised by a suitably competent person. Installation and operating personnel should be trained in the correct use of the product according to the Installation and Maintenance Instructions.

Where a formal 'permit to work' system is in force it must be complied with. Where there is no such system, it is recommended that a responsible person should know what work is going on and, where necessary, arrange to have an assistant whose primary responsibility is safety.

Post 'warning notices' if necessary.

1.12 Handling

Manual handling of large and/or heavy products may present a risk of injury. Lifting, pushing, pulling, carrying or supporting a load by bodily force can cause injury particularly to the back. You are advised to assess the risks taking into account the task, the individual, the load and the working environment and use the appropriate handling method depending on the circumstances of the work being done.

1.13 Residual hazards

In normal use the external surface of the product may be very hot.

Many products are not self-draining. Take due care when dismantling or removing the product from an installation.

1.14 Freezing

Provision must be made to protect products which are not self-draining against frost damage in environments where they may be exposed to temperatures below freezing point.

1.15 Disposal

Unless otherwise stated in the Installation and Maintenance Instructions, this product is recyclable and no ecological hazard is anticipated with its disposal providing due care is taken.

1.16 Returning products

Customers and stockists are reminded that under EC Health, Safety and Environment Law, when returning products to Spirax Sarco they must provide information on any hazards and the precautions to be taken due to contamination residues or mechanical damage which may present a health, safety or environmental risk. This information must be provided in writing including Health and Safety data sheets relating to any substances identified as hazardous or potentially hazardous.

2. General product information

CAUTION: Suitable anti-static precautions must be observed during installation and maintenance.

2.1 Description

The PA420 preamplifier is a loop powered level transmitter for use with a Spirax Sarco capacitance probe. It outputs 4 - 20 mA current signal, proportional to the water level in a tank or boiler. This signal is compatible with Spirax Sarco and standard industrial controls which are used to control or monitor level.

It has two buttons and a dual coloured light (red and green) for use at commissioning.

It consists of a tubular austenitic stainless steel body which screws onto the top of the probe, and has a DIN 43650 connector with a Pg 11 cable gland (see Figure 1) - **Do not replace the gland with anything other than a Pg 11.**

Approvals:

- TÜV, VdTÜV-Merkblatt, Wasserstand 100 - 2010.
- Electromagnetic Compatibility Directive 2004 / 08 / EG.

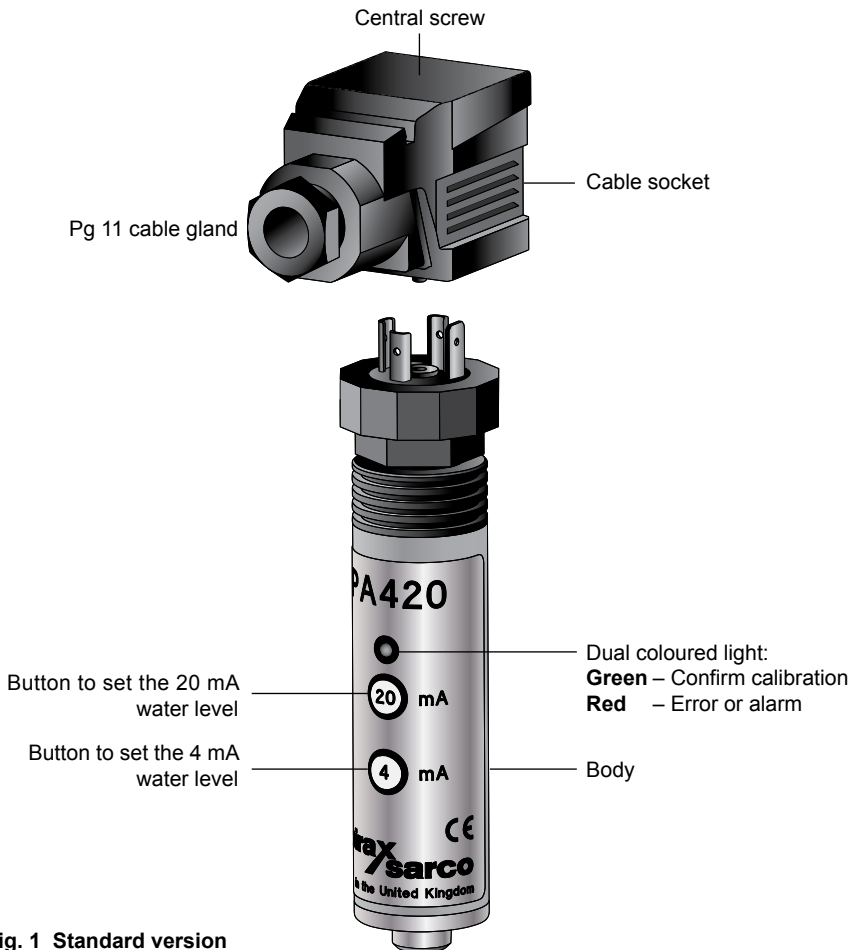

Fig. 1 Standard version

3. Installation

CAUTIONS:

- Do not install the PA420 outdoors without additional weather protection.
- Suitable anti-static precautions must be observed during installation.
- Use of a wrench will cause damage to the 'O' ring and may damage the preamplifier.

The preamplifier may be fitted to the capacitance probe before or after installation in the boiler or tank. Always allow the PA420 to stabilise at its normal operating temperature for at least 15 minutes before commissioning the controller/transmitter.

- Fit the 'O' ring supplied with the unit to the base of the male thread on the capacitance probe.
Note: Both the probe and the PA420 are provided with an 'O' ring - fit only one of these.
- Fit the preamplifier to the probe and hand tighten only.

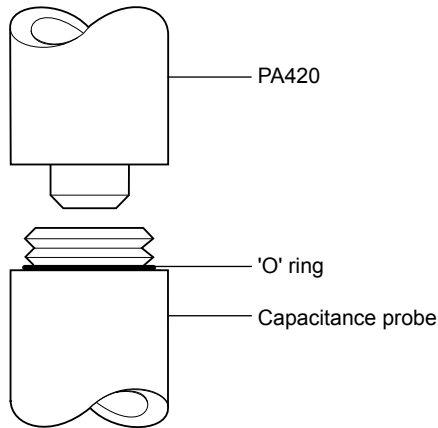

Fig. 2

4. Wiring

4.1 General information

Cabling should be installed in accordance with BS 6739 - Instrumentation in Process Control Systems: Installation design and practice or local equivalent. For the US and Canadian installation, the preamplifier must be wired in accordance with local and National Electrical Codes (NEC) or Canadian Electrical Code (CEC).

Ensure that sufficient cable length is provided to allow removal of the preamplifier, and to ensure that no strain is placed on the unit or cable socket.

See technical specification for the cable specification.

CAUTION:

Do not install signal cables near high voltage cables or switchgear.

Probe cabling must not use the same conduit/wiring trays as power cables.

Suitable anti-static precautions must be observed during installation and maintenance.

4.2 Wiring diagram and screen connection

An earth current loop is created if a wire or screen is connected between two earth points, which are at different potential (voltage). If the instructions are followed correctly, then the preamplifier and controller screen will only be connected to earth at one end (See Figure 3). The PA420 earth terminal is for the connection of the screen only. It provides a sink/drain for any electrical interference rather than a protective earth. A protective earth provides protection from electric shock under a single fault condition. This product does not require a protective earth.

CAUTION:

Do not connect the common terminal to an earth local to the controller. To do so may induce an earth current loop, which may reduce the performance or damage the product. Ensure resistance from probe body to pipework/boiler shell is less than 1 Ω .

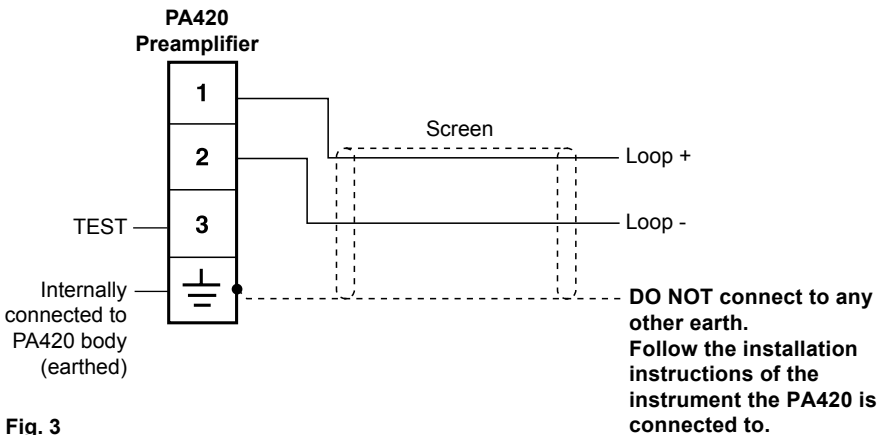

Fig. 3

4.3 Cable socket

To unplug the cable socket, remove the central screw (see Figure 1).

Note: To provide environmental protection the PA420 is supplied with a square flat gasket between the cable socket and the preamplifier connector. To maintain environmental integrity, ensure that the gasket is always present when reconnecting the cable socket and that all contact surfaces are undamaged and clean.

To gain access to the connector block within the cable socket, remove the central screw and withdraw the hinged cover.

The connector block on the standard PA420 may be rotated in 90° steps to facilitate wiring:

- Remove the retaining screw and hinged cover and withdraw the socket.

WARNING

Before applying power to the PA420, disconnect the cable socket and ensure that the supply voltage between Pin 1 and Pin 2 is within the specified rating. See Section 8 'Technical data': Exceeding the maximum voltage rating will damage the PA420.

5. Commissioning

5.1 Water level calibration

The PA420 can be configured to output between 4 mA and 20 mA for a range of water levels. The product can output 20 mA at a high water level and 4 mA for a low water level. Alternatively the product can output 4 mA at a high water level and 20 mA for a low water level. Commissioning is performed using two buttons and a dual coloured light.

Refer to Section 8 for the minimum / maximum calibration span.

To configure the water levels:

Step 1: Set the water level to the desired 4 mA or 20 mA level.

Step 2: Press the 4 mA or 20 mA button for three seconds

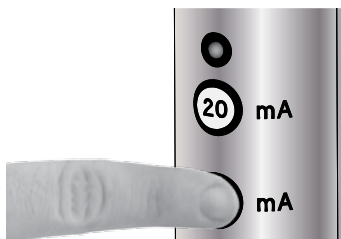

Step 3: The light will flash green once.

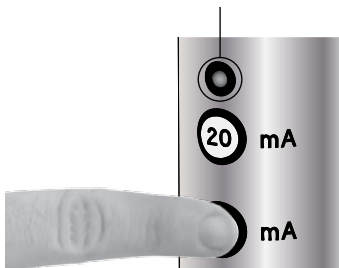

Step 4: Release the button. (You will be allowed two seconds to do this)

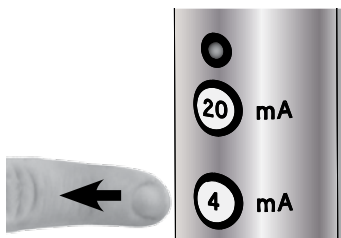

Step 5: The light will flash green again to confirm the level has been saved in non-volatile memory.

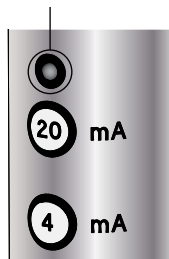

Step 6: Repeat the above to configure the second water level.

Note: Holding or releasing the button for longer or shorter periods of times, will result in the LED flashing red. The new calibration will not be saved.

Figure 4 gives an example how to commission the PA420 in relation to the gauge glass.

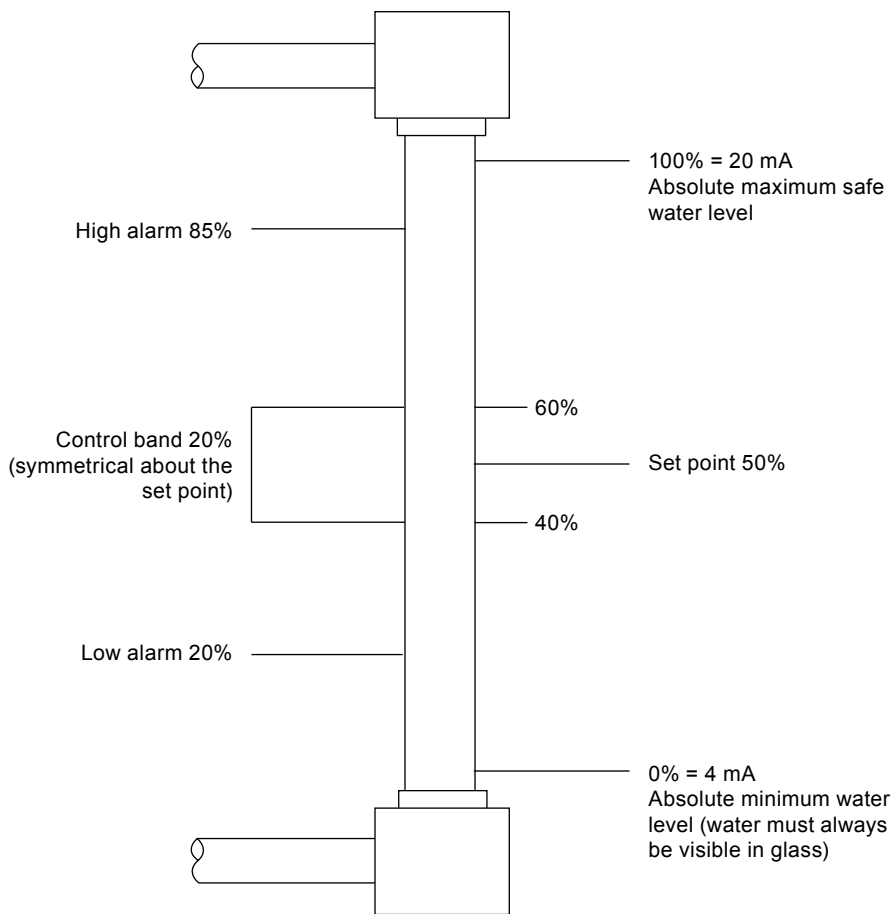

Fig. 5

Warning: If the product detects a fault, the light will flash red once a second and the output will transmit a low level signal. See Section 8, Technical Data, Alarm state and Section 7 Fault finding. Ensure the controlling product is configured to shut the system down safely.

6. Maintenance

CAUTION: Suitable anti-static precautions must be observed during any maintenance procedure.

Probe body cleaning instructions - Use a cloth dampened with tap / de-ionised water or isopropyl alcohol. Use of other cleaning materials could damage the product and invalidate the warranty.

Boiler water level controls - Require regular testing and inspection. For specific testing instructions for Spirax Sarco systems please see separate literature.

7. Fault finding

WARNING:

Before commencing fault finding, read the Safety information in Section 1

Introduction

The most likely time for faults to occur is during installation and commissioning.

7.1 Generic faults

Symptom	Explanation	Action
1 No output current	No signal There is not enough voltage to power the product or the product has been damaged. Product may recover if the fault is removed.	<ol style="list-style-type: none">1. Check that the ambient temperature is within specification - See Section 8.2.2. Unplug the connector.3. Check that all wiring is correct - See Section 4.4. Check that the wiring is secure.5. Check the voltage across terminals 1 and 2 and ensure it is within specification - See Section 8.3.6. Check the polarity of the supply.7. Plug the connector back in.8. Check the loop current is within specification - See Figure 6.9. Check the probe wire screen is correctly connected - See Figure 3.10. Check the probe wire is not routed beside other cable that may interfere with the product (e.g. mains cables).11. Check the product is not located beside a radio transmitting device.

7.2 System alarms

When an alarm occurs, the light will flash red and set the current output to the alarm state. See technical data section. To assist in diagnosis, the light flashes in a continuous sequence, separated with a pause. The alarm can be cleared by power cycling the product, once the fault is corrected

Symptom	Explanation	Action
<p style="text-align: center;">1</p> <p>Light flashing red repeatedly and alarm output</p>	<p>Program integrity The product program has been corrupted.</p>	<ol style="list-style-type: none"> 1. Return product to your local Spirax Sarco representative. 2. Before installing a replacement product, follow the actions in Section 7.1 'Generic faults'.
<p style="text-align: center;">2</p> <p>Light flashes red 2 times repeatedly and alarm output</p>	<p>Level input was too low The measured level signal from the LP20 was too low.</p>	<ol style="list-style-type: none"> 1. Check probe installation. 2. Check the connection between the LP20 and vessel. 3. Check the connection between the probe and the preamplifier. 4. Before installing a replacement product, follow the actions in Section 7.1 'Generic faults'.
<p style="text-align: center;">3</p> <p>Light flashes red 3 times repeatedly and alarm output</p>	<p>Level input was too high The measured level signal from the LP20 was too high.</p>	<ol style="list-style-type: none"> 1. Check probe installation. 2. Check the distance between the probe and any metal work. 3. Check the connection between the probe and the preamplifier. 4. Verify the insulation on the LP20 has not been damaged. 5. Before installing a replacement product, follow the actions in Section 7.1 'Generic faults'.

7.3 System errors

When an error occurs, the light will flash red. To assist in diagnosis, the light will flash in a continuous sequence, separated with a pause. The error can be cleared by pressing one of the buttons. The product will continue to output a current proportional to water level, with the parameters currently saved in memory.

Symptom	Explanation	Action
<p>1</p> <p>Light flashes red once</p>	<p>Button not held long enough</p> <p>During commissioning the button was not held down long enough.</p> <p>The level input was not saved in memory.</p>	<ol style="list-style-type: none"> 1. Repeat the commissioning routine in Section 5. 2. Follow the actions in Section 7.1 'Generic faults'.
<p>2</p> <p>Light flashes red 2 times repeatedly</p>	<p>Button held too long</p> <p>During commissioning the button was held down for too long.</p> <p>The level input was not saved in memory.</p>	<ol style="list-style-type: none"> 1. Repeat the commissioning routine in Section 5. 2. Follow the actions in Section 7.1 'Generic faults'.
<p>3</p> <p>Light flashes red 3 times repeatedly</p>	<p>Both buttons pressed</p> <p>The product is designed to ignore the buttons if both are pressed together.</p> <p>The level input was not saved in memory.</p>	<ol style="list-style-type: none"> 1. Check the button has not been damaged. 2. Check around the product, to ensure that nothing is pressing on the buttons. 3. Follow the actions in Section 7.1 'Generic faults'.
<p>4</p> <p>Light flashes red 4 times repeatedly</p>	<p>Commissioning level input out-of-range</p> <p>During commissioning the level calibration points were too close.</p> <p>The level input was not saved in memory.</p>	<ol style="list-style-type: none"> 1. Repeat the commissioning routine in Section 5 ensuring that the minimum distance between the two calibration points is maintained. See Section 8 'Technical data'.

Symptom	Explanation	Action
<p>5</p> <p>Light flashes red 5 times repeatedly</p>	<p>Memory contents conflict</p> <p>During commissioning, the product attempted to save the level signal into non-volatile memory. However an unexpected value was read back.</p>	<ol style="list-style-type: none"> 1. Follow the actions in Section 7.1 'Generic faults'. 2. Repeat the commissioning routine in Section 5.
<p>6</p> <p>Light flashes red 6 times repeatedly</p>	<p>Watchdog timeout</p> <p>The internal microcontroller has briefly stopped and recovered automatically.</p>	<ol style="list-style-type: none"> 1. Follow the actions in Section 7.1 'Generic faults'. 2. Monitor, data log and record the supply voltage over a period of time.

If the problem persists, return the product to your local Spirax Sarco representative.

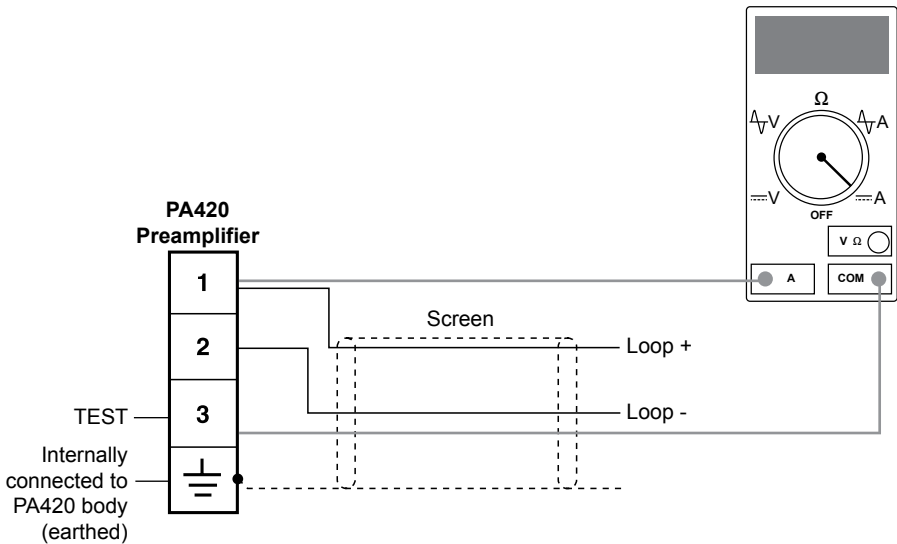

Fig. 6 Measuring the loop current
 (Please note that you don't need to disconnect the installation wiring)

8. Technical data

8.1 For technical assistance

Contact your local Spirax Sarco representative. Details can be found on accompanying order/delivery documentation or on our web site:

www.spiraxsarco.com

Returning faulty equipment

Return all items to your local Spirax Sarco representative. Ensure all items are suitably packed for transit (preferably in the original cartons).

Please provide the following information with any equipment being returned:

1. Your name, company name, address and telephone number, order number and invoice and return delivery address.
2. Description and serial number of equipment being returned.
3. Full description of the fault or repair required.
4. If the equipment is being returned under warranty, please indicate:
 - a. Date of purchase.
 - b. Original order number.

8.2 Limiting conditions

Ambient temperature range	0 - 70°C (32 - 158°F)
Pollution degree	3
Water conductivity	5 µS / cm or 5 ppm
Maximum cable length	100 m (328 ft) screened
Recommended cable	2-core, 1 mm ² (18-16 AWG), High temperature screened cable e.g.: Pirelli FP 200 or Delta Crompton Firetuf OHLS

8.3 Technical data

Voltage drop (across the device)	9 - 26.4 Vdc	
Loop current	4 - 20 mA	
Alarm state	High level = 20 mA Low level = 4 mA	3.8 mA
	High level = 4 mA Low level = 20 mA	22 mA
Maximum load	500 Ω	
Linearity	2% FSD	
Isolation	100 Vdc (capacitive)	
Calibration level	Minimum	0 mm
	Maximum	1500 mm
Calibration span	Minimum	50 mm
	Maximum	1500 mm
Resolution	1 mm	

8.4 Approvals:

- TÜV, VdTÜV-Merkblatt, Wasserstand 100 - 2010.
- Electromagnetic Compatibility Directive 2004 / 08 / EG.