LP21
Capacitance Level Probe
Installation and Maintenance Instructions



1. Safety information
2. General product information
3. How the LP21 probe works
4. Installation
5. Wiring
6. Maintenance
7. Technical assistance

1. Safety information

Your attention is drawn to any National or local regulations.

The product is designed and constructed to withstand the forces encountered during normal use. Use of the product for any other purpose, or failure to install the product in accordance with these Installation and Maintenance Instructions, could cause damage to the product and may cause injury or fatality to personnel.

Warning

If this product is not used in the manner specified by this IMI, then the protection provided may be impaired.

1.1 Intended use

The capacitance level probe LP21 is designed for use in conjunction with the Spirax Sarco level preamplifier PA420 and a Spirax Sarco level controller. If used in conjunction with other controllers then a safety power supply unit that delivers a Safety Extra Low Voltage (SELV) must be used to supply the controller/probe.

- i) Check that the product is suitable for use with the intended fluid.
- ii) Check material suitability, pressure and temperature and their maximum and minimum values. If the maximum operating limits of the product are lower than those of the system in which it is being fitted, or if malfunction of the product could result in a dangerous overpressure or overtemperature occurrence, ensure a safety device is included in the system to prevent such over-limit situations.
- iii) Determine the correct installation situation and direction of fluid flow.
- iv) Spirax Sarco products are not intended to withstand external stresses that may be induced by any system to which they are fitted. It is the responsibility of the installer to consider these stresses and take adequate precautions to minimise them.
- v) Remove protection covers from all connections and protective film from all name-plates, where appropriate, before installation on steam or other high temperature applications.

Safe operation of these products can only be guaranteed if they are properly installed, commissioned, used and maintained by qualified personnel (see Section 1.11) in compliance with the operating instructions. General installation and safety instructions for pipeline and plant construction, as well as the proper use of tools and safety equipment must also be complied with.

1.2 Access

Ensure safe access and if necessary a safe working platform (suitably guarded) before attempting to work on the product. Arrange suitable lifting gear if required.

1.3 Lighting

Ensure adequate lighting, particularly where detailed or intricate work is required.

1.4 Hazardous liquids or gases in the pipeline

Consider what is in the pipeline or what may have been in the pipeline at some previous time. Consider: flammable materials, substances hazardous to health, extremes of temperature.

1.5 Hazardous environment around the product

Consider: explosion risk areas, lack of oxygen (e.g. tanks, pits), dangerous gases, extremes of temperature, hot surfaces, fire hazard (e.g. during welding), excessive noise, moving machinery.

1.6 The system

Consider the effect on the complete system of the work proposed. Will any proposed action (e.g. closing isolation valves, electrical isolation) put any other part of the system or any personnel at risk? Dangers might include isolation of vents or protective devices or the rendering ineffective of controls or alarms. Ensure isolation valves are turned on and off in a gradual way to avoid system shocks.

1.7 Pressure systems

Ensure that any pressure is isolated and safely vented to atmospheric pressure. Consider double isolation (double block and bleed) and the locking or labelling of closed valves. Do not assume that the system has depressurised even when the pressure gauge indicates zero.

1.8 Temperature

Allow time for temperature to normalise after isolation to avoid danger of burns.

1.9 Tools and consumables

Before starting work ensure that you have suitable tools and/or consumables available. Use only genuine Spirax Sarco replacement parts.

1.10 Protective clothing

Consider whether you and/or others in the vicinity require any protective clothing to protect against the hazards of, for example, chemicals, high/low temperature, radiation, noise, falling objects, and dangers to eyes and face.

1.11 Permits to work

All work must be carried out or be supervised by a suitably competent person. Installation and operating personnel should be trained in the correct use of the product according to the Installation and Maintenance Instructions. Where a formal 'permit to work' system is in force it must be complied with. Where there is no such system, it is recommended that a responsible person should know what work is going on and, where necessary, arrange to have an assistant whose primary responsibility is safety. Post 'warning notices' if necessary.

1.12 Handling

Manual handling of large and/or heavy products may present a risk of injury. Lifting, pushing, pulling, carrying or supporting a load by bodily force can cause injury particularly to the back. You are advised to assess the risks taking into account the task, the individual, the load and the working environment and use the appropriate handling method depending on the circumstances of the work being done.

1.13 Residual hazards

In normal use the external surface of the product may be very hot. Many products are not self-draining. Take due care when dismantling or removing the product from an installation.

1.14 Freezing

Provision must be made to protect products which are not self-draining against frost damage in environments where they may be exposed to temperatures below freezing point.

1.15 Safety information - Product specific for level control and level limiting/alarm products in steam boilers

Products/systems must be selected, installed, operated, and tested in accordance with:

- Local or National standards and regulations.
- Guidance Notes, (Health and Safety Executive BG01 and INDG436 in the UK).
- The requirements of Approvals Authorities.
- Boiler Insurance Bodies.
- Boiler manufacturer's specifications.

Two low water level probes must be installed on steam boilers. The controller alarm relays must disconnect the boiler heat supply at low alarm status. Low level probes must be installed in separate protection tubes/chambers, with sufficient clearance between the tips, and earth (≥ 14 mm).

A combination of low water level probe and a level probe or high water level probe together in one protection tube/chamber is possible as well (check local regulations).

A high water alarm may be part of the water level control, or a separate system.

An independent high water alarm system must be fitted if it is considered a safety requirement. In this case, the relays must simultaneously isolate the feedwater supply and the boiler heat supply at high alarm status. All boiler water limiters/alarms require regular functional testing.

A suitable water treatment regime must be used to ensure continuous safe and correct operation of the control and limiter systems. Consult the above authorities and a competent water treatment company.

1.16 Disposal

Unless otherwise stated in the Installation and Maintenance Instructions, this product is recyclable and no ecological hazard is anticipated with its disposal providing due care is taken.

1.17 Returning products

Customers and stockists are reminded that under EC Health, Safety and Environment Law, when returning products to Spirax Sarco they must provide information on any hazards and the precautions to be taken due to contamination residues or mechanical damage which may present a health, safety or environmental risk. This information must be provided in writing including Health and Safety data sheets relating to any substances identified as hazardous or potentially hazardous.

2. General product information

2.1 Description

The Spirax Sarco LP21 is a capacitance level probe designed to work with a PA420 Preamplifier to provide a level transmitter. The transmitter is compatible with the Spirax Sarco range of controllers. These can be used to provide adjustable ON/OFF control, modulating control, alarms and a output for a building management system.

The probe is normally installed in a steam boiler or metal tank where it is earthed through the ½" BSP screwed connection, the boiler or tank forming the earth return path.

It may be used in a non-conductive tank (e.g. plastic or concrete) if an earth rod is provided.

The PA420 preamplifier (described in separate literature), is screwed to the top of the probe and hand tightened, enabling easy removal without the need to disturb the probe.

Caution:

The probe is not suitable for outside installation without additional environmental protection.

Note:

For additional product data see the probe Technical Information sheet.

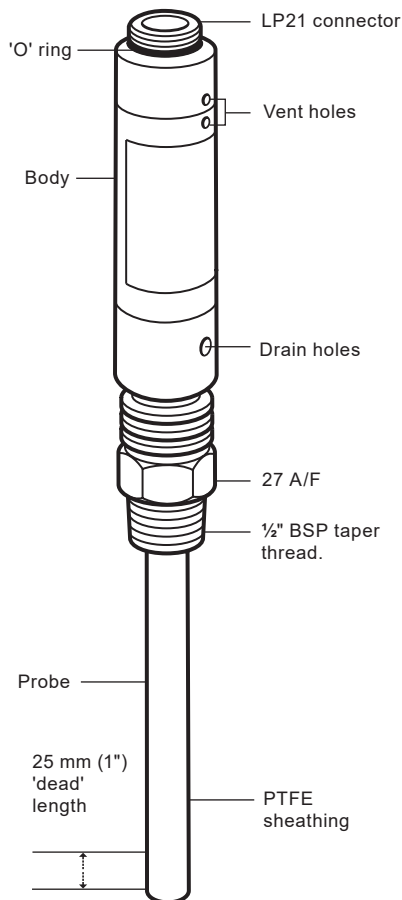

Fig. 1 Capacitance level probe

2.2 Available probe lengths (approximate) in mm

370, 470, 550, 600, 650, 750, 800, 900, 950, 1 050, 1 200, 1 350 or 1 500.

Notes:

1. Probe length includes the 25 mm 'dead' length at its tip. **The probe must not be cut to length.**
2. Probe is normally installed vertically, but for probe tip lengths of up to 500 mm (20") it may be inclined by up to 45° from the vertical.

2.3 Pressure/temperature limits

Nominal pressure rating	PN40	
Maximum pressure	32 bar g	
Maximum temperature	239 °C	
Ambient temperature	Maximum	70 °C
	Minimum	5 °C
Designed for a maximum cold hydraulic test pressure of:	60 bar g	

2.4 Technical data

Sensing depth	Probe length minus 25 mm
Minimum conductivity	5 µS/cm or 5 ppm
Degree of protection (assembled with PA420)	IP54

3. How the LP21 probe works

The probe consists of a metal rod completely insulated from the liquid by PTFE sheathing. It works by sensing the variation in capacitance caused by a change in water level, an increasing level giving a proportionally increasing output. The capacitance is measured by the preamplifier and transmitted as a dc signal to the controller. Control and switching levels are set in the controller.

CAUTION: Over-tightening by hand or use of a wrench will cause damage to the 'O' ring and may damage the preamplifier.

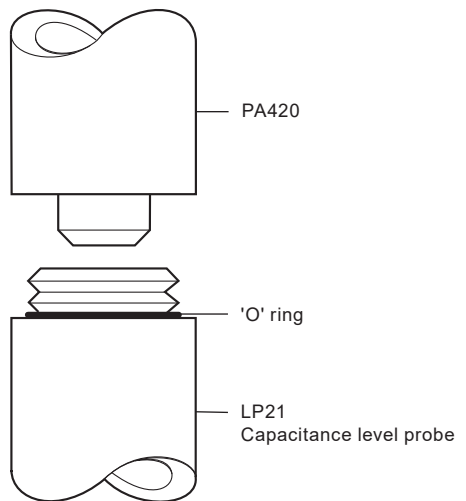

Fig. 2

4. Installation

WARNING: The LP21 probe must not be cut to length. Do not install the probe outdoors without additional weather protection. Do not block the drain or the vent holes.

A protection tube of 80 mm (3") nominal bore is required for boilers, or in tanks where turbulence is likely. This should be as long as possible, and at least long enough to cope with the expansion of the probe at maximum operating temperature (0 - 239 °C, 32 - 462 °F). Allow 20 mm (¾") clearance for probes up to 750 mm in length, and 38 mm (1½" for longer probes).

4.1 Install the probes as follows

- Ensure both male and female threads are in good condition.
- Use up to three turns (no more) of PTFE thread sealing tape on the probe thread.

WARNINGS: Do not use excessive tape. Do not use paste type jointing compound.

- Fit and tighten the probe by hand initially - use a suitable spanner to tighten the probe.

Under no circumstances use a pipe wrench.

- Due to the nature of a taper/parallel joint it is not possible to recommend tightening torque figures.
- Do not overtighten - there should always be visible thread on the probe.
- **Note:** The probe thread will not 'bottom out' (i.e. probe body hexagon contacts the face of the female screwed connection), unless there is excessive wear or an out-of-tolerance female thread, in which case it will be necessary to replace or re-work the flange or connection. After installation ensure that resistance from the probe body to the pipework/boiler shell is less than 1 Ω.

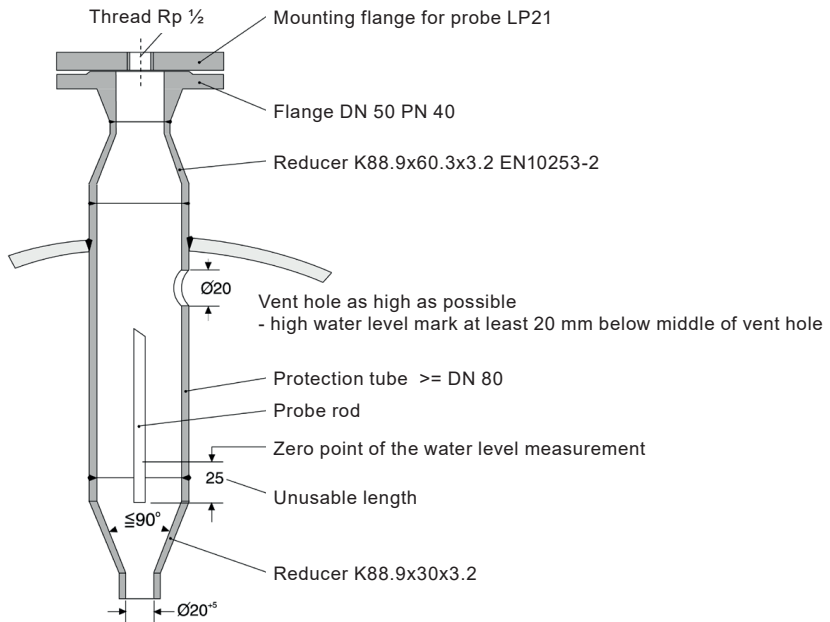

Fig. 3 Installation example 1: Inside the boiler with protection tube provided by the customer

4.2 Subsequent removal and refitting

Warning: Ensure boiler or vessel is depressurised and vented to atmosphere before attempting to unscrew or remove the probe.

- Always use the correct size spanner - not a pipe wrench.
- Inspect male and female threads for signs of damage, which may have occurred through overtightening, leading to torn threads or even localised cold welding (galling/picking up).
- If damage has occurred replace the probe.
- Carry out an electrical continuity check to ensure that the resistance between the probe body and the boiler or tank is less than 1 Ω .
- An 'O' ring is supplied with both the LP21 and PA420. Ensure only one 'O' ring is fitted between the probe and the PA420 preamplifier (see Figure 2).

The preamplifier must only be screwed on hand tight to avoid damage to the 'O' ring.

Refer to the preamplifier IMI for further information.

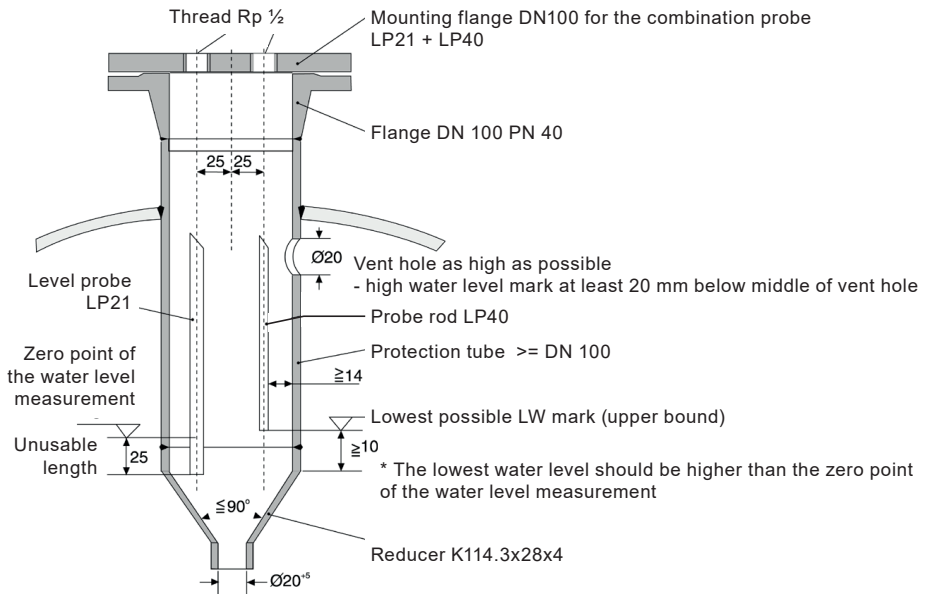

Fig. 4 Installation example 2: Combination with water level limiter probe LP40

5. Wiring

Refer to the preamplifier and controller Installation and Maintenance Instructions for wiring details and diagrams.

6. Maintenance

Note: Read the 'Safety information' in Section 1 before starting any maintenance.

No special servicing, preventative maintenance or inspection of the product is required.

Level controls

Boiler water level controls and level alarms, however, do require testing and inspection. General guidance is given in Health and Safety Executive Guidance Notes BG01 and INDG436.

For specific instructions for the Spirax Sarco system please see separate literature.

Cleaning instructions

Use a cloth dampened with tap/de-ionised water or isopropyl alcohol. Use of other cleaning materials could damage the product and invalidate the warranty.

7. Technical assistance

Contact your local Spirax Sarco representative. Details can be found on accompanying order/delivery documentation or on our web site:

www.spiraxsarco.com

Returning faulty equipment

Return all items to your local Spirax Sarco representative. Ensure all items are suitably packed for transit (preferably in the original cartons).

Please provide the following information with any equipment being returned:

1. Your name, company name, address and telephone number, order number and invoice and return delivery address.
2. Description and serial number of equipment being returned.
3. Full description of the fault or repair required.
4. If the equipment is being returned under warranty, please indicate:
 - a. Date of purchase.
 - b. Original order number.

Spirax Sarco Ltd
Runnings Road
Cheltenham
GL51 9NQ
United Kingdom

www.spiraxsarco.com