

IFTGS14 Ball Float Steam Trap

1/2" and 3/4" with Integral Spiratec Sensor

Installation and Maintenance Instructions

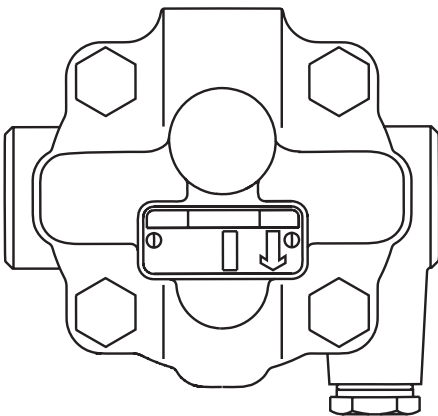

1. Safety information
2. General product information
3. Installation
4. Commissioning
5. Operation
6. Maintenance
7. Spare parts

1. Safety information

Safe operation of this product can only be guaranteed if it is properly installed, commissioned, used and maintained by qualified personnel (see Section 1.11) in compliance with the operating instructions. General installation and safety instructions for pipeline and plant construction, as well as the proper use of tools and safety equipment must also be complied with.

1.1 Intended use

Referring to the Installation and Maintenance Instructions, name-plate and Technical Information Sheet, check that the product is suitable for the intended use/application. The IFTGS14 complies with the requirements of the EU Pressure Equipment Directive/UK Pressure Equipment Regulations and falls within category 'SEP'.

It should be noted that products within this category are required by the Directive not to carry the  mark:

- i) The product has been specifically designed for use on steam, air or water/condensate which is in Group 2 of the above mentioned Pressure Equipment Directive. The products' use on other fluids may be possible but, if this is contemplated, Spirax Sarco should be contacted to confirm the suitability of the product for the application being considered.
- ii) Check material suitability, pressure and temperature and their maximum and minimum values. If the maximum operating limits of the product are lower than those of the system in which it is being fitted, or if malfunction of the product could result in a dangerous overpressure or overtemperature occurrence, ensure a safety device is included in the system to prevent such over-limit situations.
- iii) Determine the correct installation situation and direction of fluid flow.
- iv) Spirax Sarco products are not intended to withstand external stresses that may be induced by any system to which they are fitted. It is the responsibility of the installer to consider these stresses and take adequate precautions to minimise them.
- v) Remove protection covers from all connections and protective film from all name-plates, where appropriate, before installation on steam or other high temperature applications.

1.2 Access

Ensure safe access and if necessary a safe working platform (suitably guarded) before attempting to work on the product. Arrange suitable lifting gear if required.

1.3 Lighting

Ensure adequate lighting, particularly where detailed or intricate work is required.

1.4 Hazardous liquids or gases in the pipeline

Consider what is in the pipeline or what may have been in the pipeline at some previous time. Consider: flammable materials, substances hazardous to health, extremes of temperature.

1.5 Hazardous environment around the product

Consider: explosion risk areas, lack of oxygen (e.g. tanks, pits), dangerous gases, extremes of temperature, hot surfaces, fire hazard (e.g. during welding), excessive noise, moving machinery.

1.6 The system

Consider the effect on the complete system of the work proposed. Will any proposed action (e.g. closing isolation valves, electrical isolation) put any other part of the system or any personnel at risk?

Dangers might include isolation of vents or protective devices or the rendering ineffective of controls or alarms. Ensure isolation valves are turned on and off in a gradual way to avoid system shocks.

1.7 Pressure systems

Ensure that any pressure is isolated and safely vented to atmospheric pressure. Consider double isolation (double block and bleed) and the locking or labelling of closed valves. Do not assume that the system has depressurised even when the pressure gauge indicates zero.

1.8 Temperature

Allow time for temperature to normalise after isolation to avoid danger of burns.

1.9 Tools and consumables

Before starting work ensure that you have suitable tools and/or consumables available. Use only genuine Spirax Sarco replacement parts.

1.10 Protective clothing

Consider whether you and/or others in the vicinity require any protective clothing to protect against the hazards of, for example, chemicals, high/low temperature, radiation, noise, falling objects, and dangers to eyes and face.

1.11 Permits to work

All work must be carried out or be supervised by a suitably competent person.

Installation and operating personnel should be trained in the correct use of the product according to the Installation and Maintenance Instructions.

Where a formal 'permit to work' system is in force it must be complied with. Where there is no such system, it is recommended that a responsible person should know what work is going on and, where necessary, arrange to have an assistant whose primary responsibility is safety.

Post 'warning notices' if necessary.

1.12 Handling

Manual handling of large and/or heavy products may present a risk of injury. Lifting, pushing, pulling, carrying or supporting a load by bodily force can cause injury particularly to the back. You are advised to assess the risks taking into account the task, the individual, the load and the working environment and use the appropriate handling method depending on the circumstances of the work being done.

1.13 Residual hazards

In normal use the external surface of the product may be very hot. If used at the maximum permitted operating conditions the surface temperature of some products may reach temperatures in excess of 250 °C (482 °F).

Many products are not self-draining. Take due care when dismantling or removing the product from an installation (refer to 'Maintenance instructions').

1.14 Freezing

Provision must be made to protect products which are not self-draining against frost damage in environments where they may be exposed to temperatures below freezing point.

1.15 Disposal

Unless otherwise stated in the Installation and Maintenance Instructions, this product is recyclable and no ecological hazard is anticipated with its disposal providing due care is taken.

1.16 Returning products

Customers and stockists are reminded that under EC Health, Safety and Environment Law, when returning products to Spirax Sarco they must provide information on any hazards and the precautions to be taken due to contamination residues or mechanical damage which may present a health, safety or environmental risk. This information must be provided in writing including Health and Safety data sheets relating to any substances identified as hazardous or potentially hazardous.

2. General product information

2.1 General description

The IFTGS14 is a maintainable ball float steam trap with integral automatic air venting facility. It is available with horizontal connections and has a stainless steel body and an electroless nickel plated SG iron cover offering increased resistance to erosion.

The IFTGS14 can be simply intergrated into all existing Spiratec monitoring systems.

Available options:

SS1	Sensor to detect steam leakage only.
WLS1	Sensor to detect waterlogging and steam leakage.
WLS1 and Diode pack	Sensor to detect waterlogging and steam leakage for use with R16C steam trap monitor.

Standards

The product fully complies with the requirements of the EU Pressure Equipment Directive/UK Pressure Equipment Regulations.

Certification

This product is available with a manufacturers Typical Test Report.

Note: All certification/inspection requirements must be stated at the time of order placement.

Note: For further information see the following Technical Information sheet: TI-P615-11.

2.2 Sizes and pipe connections

½" and ¾" screwed BSP or NPT.

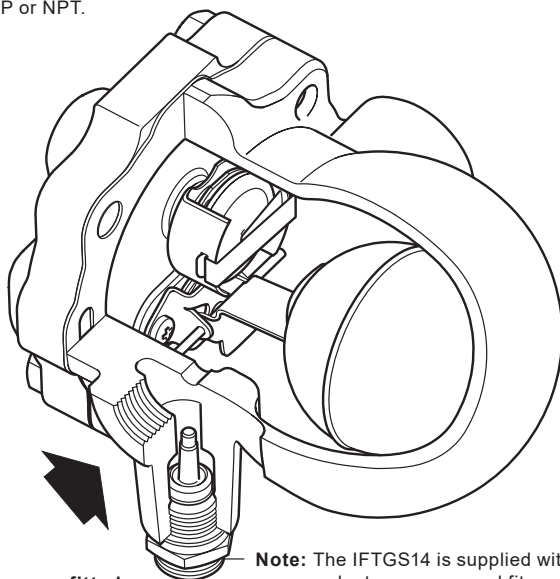
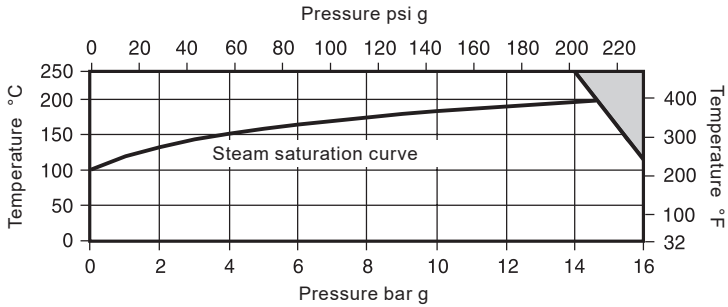

Fig. 1 IFTGS14 with sensor fitted

Note: The IFTGS14 is supplied with a steel plug in the sensor adaptor, remove and fit sensor on site.

2.3 Pressure/temperature limits (ISO 6552)



The product **must not** be used in this region.

Body design conditions		PN16	
PMA	Maximum allowable pressure	16 bar g @ 120 °C	(232 psi g @ 248 °F)
TMA	Maximum allowable temperature	250 °C	(482 °F)
	Minimum allowable temperature	-10 °C	(14 °F)
PMO	Maximum operating pressure for saturated steam service	14.6 bar g	(211.7 psi g)
TMO	Maximum operating temperature	250 °C @ 13.8 bar g	(482 °F @ 200 psi g)
	Minimum operating temperature	0 °C	(32 °F)
		FTGS14-4.5	4.5 bar (65.25 psi g)
ΔPMX	Maximum differential pressure	FTGS14-10	10 bar (145 psi g)
		FTGS14-14	14 bar (203 psi g)
Designed for a maximum cold hydraulic test pressure of:		24 bar g	(348 psi g)

3. Installation

Note: Before actioning any installation observe the 'Safety information' in Section 1.

Referring to the Installation and Maintenance Instructions, name-plate and Technical Information Sheet, check that the product is suitable for the intended installation.

Warning: The cover gasket (item 3, Figure 2) contains a thin stainless steel support ring which may cause physical injury if not handled and disposed of carefully.

- 3.1** Check materials, pressure and temperature and their maximum values. If the maximum operating limit of the product is lower than that of the system in which it is being fitted, ensure that a safety device is included in the system to prevent overpressurisation.
- 3.2** Determine the correct installation situation and the direction of fluid flow.
- 3.3** Install a Y-type strainer immediately upstream of the trap to remove all pipeline debris.
- 3.4** Remove protection covers from all connections and protective film from all name-plates, where appropriate, before installation on steam or other high temperature applications.

Installation notes:

- If the trap is to discharge to atmosphere ensure it is to a safe place, the discharging fluid may be at a temperature of 100 °C (212 °F).
- The trap must be fitted with the float arm in a horizontal plane so that it rises and falls vertically, therefore the arrow on the name-plate must point downwards.
- Traps are only available with horizontal connections allowing flow from right to left (when looking at the name-plate), see Figure 1.
- Minimum withdrawal distance to remove the cover is 105 mm (4.13").
- Minimum withdrawal distance to remove the sensor is 130 mm (5.11").

Installation of the steam sensor (SS1)

- 3.5** The trap is supplied with a plug in the sensor connection on the cover.
- 3.6** Before fitting the sensor, isolate the trap from both the supply line and the return line, and allow any pressure remaining in the pipeline to safely normalise to atmosphere.
- 3.7** Allow the trap to cool - Remove the plug from the trap and clean away any dirt before fitting the sensor. Screw the sensor into the trap ensuring the gasket is centralised and tighten to the recommended torque (see Table 1, page 8).

Installation of the waterlogging sensor (WLS1)

- 3.8** For fitting the waterlogging sensor refer to Sections 3.5, 3.6 and 3.7 above and the Installation and Maintenance Instructions (IM-P087-34) which is provided with the sensor.

Please consult Spirax Sarco should further information be required.

4. Commissioning

After installation or maintenance ensure that the system is fully functioning. Carry out tests on any alarms or protective devices.

The trap is supplied with a plug in the sensor connection on the cover. It is recommended that the trap be operated under normal conditions for 24 hours before the plug is removed. This will allow pipeline debris to be removed from the Y-type strainer prior to the sensor being installed.

Note: Failure to complete this commissioning process may affect the operation of the sensor.

5. Operation

The float trap is a continuous discharge trap, removing condensate the instant it forms. On start-up, the thermostatic air vent allows air to bypass the main valve preventing the system air binding. Hot condensate will close the air vent tightly, but as soon as it enters the main chamber of the trap, the float rises and the lever mechanism attached to it opens the main valve - keeping the system drained of condensate at all times. When steam arrives, the float drops and closes the main valve. Float traps are renowned for their high start-up load handling capability, clean tight shut-off and resistance to waterhammer and vibration.



6. Maintenance

Note: Before actioning any maintenance programme observe the 'Safety information' in Section 1.

Warning

The cover gasket (item 3) contains a thin stainless steel support ring which may cause physical injury if not handled and disposed of carefully.

Table 1 Recommended tightening torques

Item	Part	 or mm		N m	(lbf ft)
2	Cover bolts	17 A/F	M10 x 30	47 - 50	(35 - 37)
5	Main valve seat	17 A/F		50 - 55	(37 - 40)
7	Main valve assembly screws	Pozidrive	M4 x 6	2.5 - 3.0	(1.8 - 2.2)
9	Air vent assembly	17 A/F		50 - 55	(37 - 40)
24	Sensor	24 A/F		50 - 55	(37 - 40)
27	ITS blanking plug	22 A/F		50 - 55	(37 - 40)

IFTGS14 Ball Float Steam Trap ½" and ¾" with Integral Spiratec Sensor

6.1 General information

Before undertaking any maintenance on the trap it must be isolated from both the supply line and return line and any pressure allowed to safely normalise to atmosphere. The trap should then be allowed to cool. When reassembling, ensure that all joint faces are clean.

6.2 How to replace or clean the sensor:

- Important note: If a waterlogging sensor is fitted, it will be necessary to disconnect the wiring at the terminal block.
- The sensor (24) should periodically be removed to inspect and clean the insulation as a build-up of pipeline residue may affect the function of the sensor. Frequency of inspection will be dictated by condensate quality.
- Remove the sensor (24) from the trap, clean the sensor insulation.
- If pitting of the insulation occurs, a new sensor should be fitted. Replace the sensor ensuring that the gasket (25) is centralised. Tighten to the recommended torque (see Table 1).
- Reconnect the waterlogging sensor as described in IM-P087-34.

6.3 How to fit the main valve assembly:

- Undo the cover bolts (2) and lift off the body (1).
- Remove the complete float assembly (7, 8, 10 and 11) by undoing the two screws (7).
- Remove the main valve seat (5) and replace with a new one supplied with new gasket (6).
- Fit a complete new float assembly by tightening the assembly set screws (7) to the recommended torque (see Table 1).
- Refit the body (1) using a new gasket (3).

6.4 How to fit the air vent assembly:

- Remove the spring clip, element and spacer plate (17).
- Unscrew the seat.
- Fit a new gasket (18), seat and frame.
- Assemble the spacer plate, fit element and clips.
- Align the complete air vent (17) horizontally so that the frame clears the cover.
- Refit the body (1) using a new gasket (3).

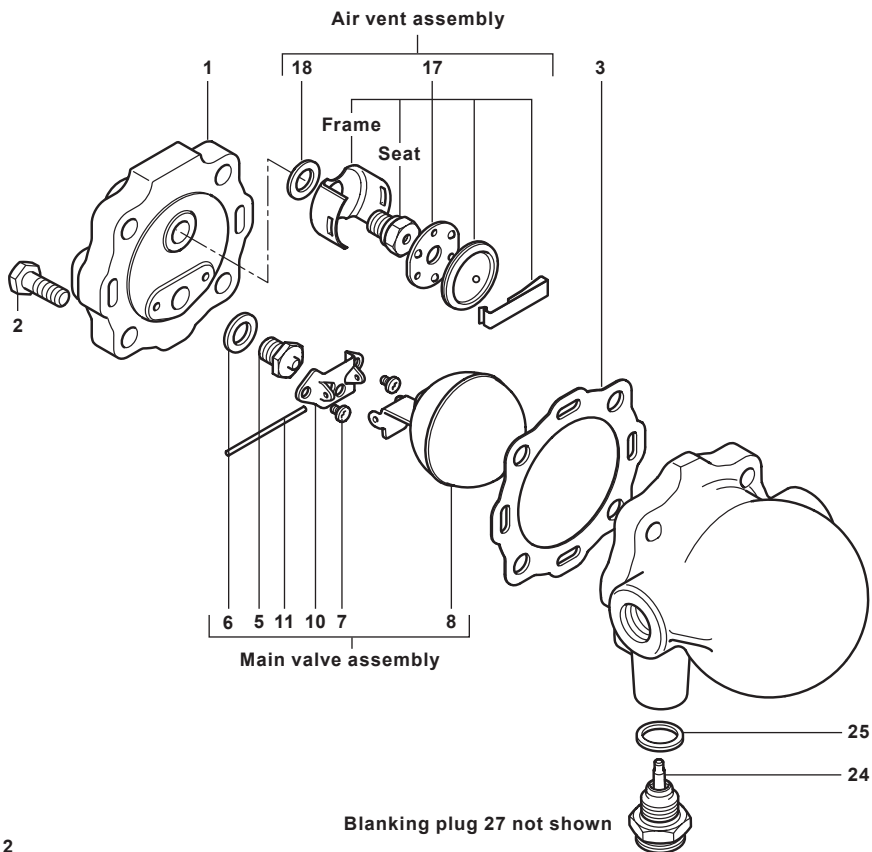

Fig. 2

7. Spare parts

The spare parts available are shown in solid outline. Parts drawn in a grey line are not supplied as spares.

Available spares

Maintenance kit	3, 5, 6, 7 (2 off), 8, 10, 11, 17, 18
Main valve assembly	3, 5, 6, 7 (2 off), 8, 10, 11
Air vent assembly	3, 17, 18
Sensor and sensor gasket	24, 25
Cover gasket (packet of 3)	3

How to order spares

Always order spares by using the description given in the column headed 'Available spares' and state the size, type of trap and pressure range.

Example: 1 - Air vent assembly for a Spirax Sarco ½" IFTGS14-4.5 ball float steam trap.

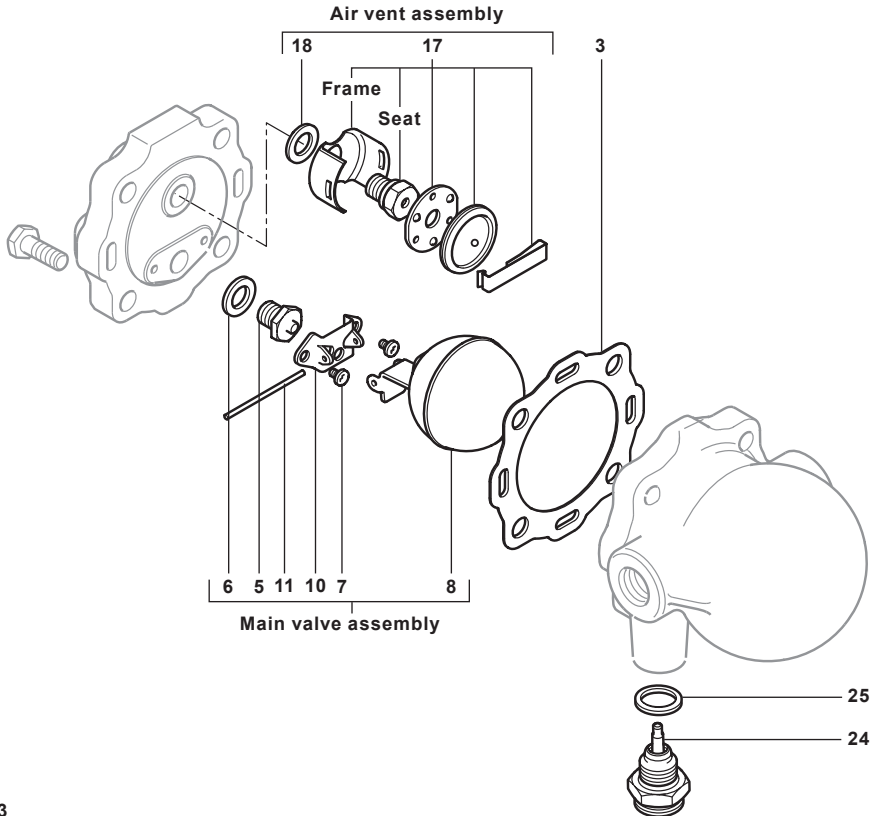

Fig. 3