

FT12

Cast Iron Float/Orifice Trap

Installation and Maintenance Instructions

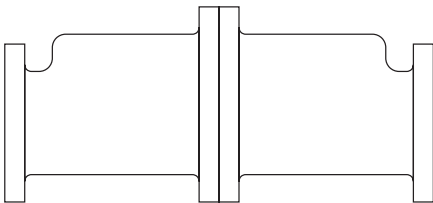

1. Safety information
2. General product information
3. Installation
4. Commissioning
5. Operation
6. Maintenance
7. Spare parts

1. Safety information

Safe operation of these products can only be guaranteed if they are properly installed, commissioned, used and maintained by qualified personnel (see Section 1.11) in compliance with the operating instructions. General installation and safety instructions for pipeline and plant construction, as well as the proper use of tools and safety equipment must also be complied with.

Warning

The inner and outer gaskets used when installing/maintaining the UIB to a PC_ pipeline connector contain thin stainless steel support rings which may cause physical injury if not handled and disposed of carefully.

1.1 Intended use

Referring to the Installation and Maintenance Instructions, name-plate and Technical Information Sheet, check that the product is suitable for the intended use/application.

The products listed below comply with the requirements of the Pressure Equipment Directive (PED) and carry the  mark when so required. The products fall within the following Pressure Equipment Directive categories:

Product	Group 2 Gases	Group 2 Liquids
FT12 DN150	1	SEP

- i) The products have been specifically designed for use on steam, air or water/condensate which are in Group 2 of the above mentioned Pressure Equipment Directive. The products' use on other fluids may be possible but, if this is contemplated, Spirax Sarco should be contacted to confirm the suitability of the product for the application being considered.
- ii) Check material suitability, pressure and temperature and their maximum and minimum values. If the maximum operating limits of the product are lower than those of the system in which it is being fitted, or if malfunction of the product could result in a dangerous overpressure or overtemperature occurrence, ensure a safety device is included in the system to prevent such over-limit situations.
- iii) Determine the correct installation situation and direction of fluid flow.
- iv) Spirax Sarco products are not intended to withstand external stresses that may be induced by any system to which they are fitted. It is the responsibility of the installer to consider these stresses and take adequate precautions to minimise them.
- v) Remove protection covers from all connections and protective film from all name-plates, where appropriate, before installation on steam or other high temperature applications.

1.2 Access

Ensure safe access and if necessary a safe working platform (suitably guarded) before attempting to work on the product. Arrange suitable lifting gear if required.

1.3 Lighting

Ensure adequate lighting, particularly where detailed or intricate work is required.

1.4 Hazardous liquids or gases in the pipeline

Consider what is in the pipeline or what may have been in the pipeline at some previous time. Consider: flammable materials, substances hazardous to health, extremes of temperature.

1.5 Hazardous environment around the product

Consider: explosion risk areas, lack of oxygen (e.g. tanks, pits), dangerous gases, extremes of temperature, hot surfaces, fire hazard (e.g. during welding), excessive noise, moving machinery.

1.6 The system

Consider the effect on the complete system of the work proposed. Will any proposed action (e.g. closing isolation valves, electrical isolation) put any other part of the system or any personnel at risk?

Dangers might include isolation of vents or protective devices or the rendering ineffective of controls or alarms. Ensure isolation valves are turned on and off in a gradual way to avoid system shocks.

1.7 Pressure systems

Ensure that any pressure is isolated and safely vented to atmospheric pressure.

Consider double isolation (double block and bleed) and the locking or labelling of closed valves. Do not assume that the system has depressurised even when the pressure gauge indicates zero.

1.8 Temperature

Allow time for temperature to normalise after isolation to avoid the danger of burns.

1.9 Tools and consumables

Before starting work ensure that you have suitable tools and/or consumables available. Use only genuine Spirax Sarco replacement parts.

1.10 Protective clothing

Consider whether you and/or others in the vicinity require any protective clothing to protect against the hazards of, for example, chemicals, high/low temperature, radiation, noise, falling objects, and dangers to eyes and face.

1.11 Permits to work

All work must be carried out or be supervised by a suitably competent person.

Installation and operating personnel should be trained in the correct use of the product according to the Installation and Maintenance Instructions.

Where a formal 'permit to work' system is in force it must be complied with. Where there is no such system, it is recommended that a responsible person should know what work is going on and, where necessary, arrange to have an assistant whose primary responsibility is safety.

Post 'warning notices' if necessary.

1.12 Handling

Manual handling of large and/or heavy products may present a risk of injury. Lifting, pushing, pulling, carrying or supporting a load by bodily force can cause injury particularly to the back. You are advised to assess the risks taking into account the task, the individual, the load and the working environment and use the appropriate handling method depending on the circumstances of the work being done.

1.13 Residual hazards

In normal use the external surface of the product may be very hot. If used at the maximum permitted operating conditions the surface temperature of the product may reach temperatures up to 425 °C (797 °F).

Many products are not self-draining. Take due care when dismantling or removing the product from an installation (refer to 'Maintenance instructions').

1.14 Freezing

Provision must be made to protect products which are not self-draining against frost damage in environments where they may be exposed to temperatures below freezing point.

1.15 Disposal

Unless otherwise stated in the Installation and Maintenance Instructions, this product is recyclable and no ecological hazard is anticipated with its disposal providing due care is taken.

1.16 Returning products

Customers and stockists are reminded that under EC Health, Safety and Environment Law, when returning products to Spirax Sarco they must provide information on any hazards and the precautions to be taken due to contamination residues or mechanical damage which may present a health, safety or environmental risk. This information must be provided in writing including Health and Safety data sheets relating to any substances identified as hazardous or potentially hazardous.

1.17 Working safely with cast iron products on steam

Cast iron products are commonly found on steam and condensate systems. If installed correctly using good steam engineering practices, it is perfectly safe.

However, because of its mechanical properties, it is less forgiving compared to other materials such as SG iron or carbon steel. The following are the good engineering practices required to prevent waterhammer and ensure safe working conditions on a steam system.

Safe Handling

Cast Iron is a brittle material. If the product is dropped during installation and there is any risk of damage the product should not be used unless it is fully inspected and pressure tested by the manufacturer.

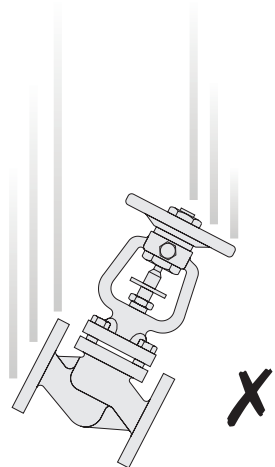

Prevention of waterhammer

Steam trapping on steam mains:

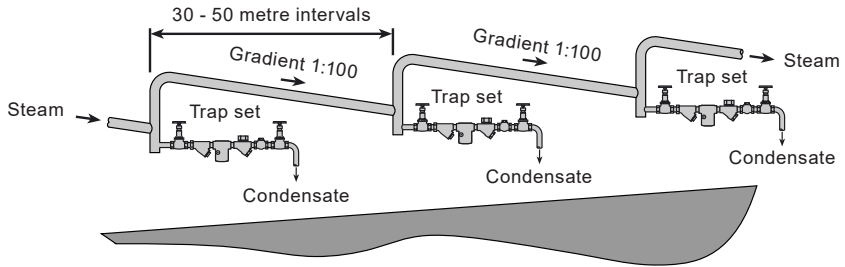

Steam Mains - Do's and Don'ts:

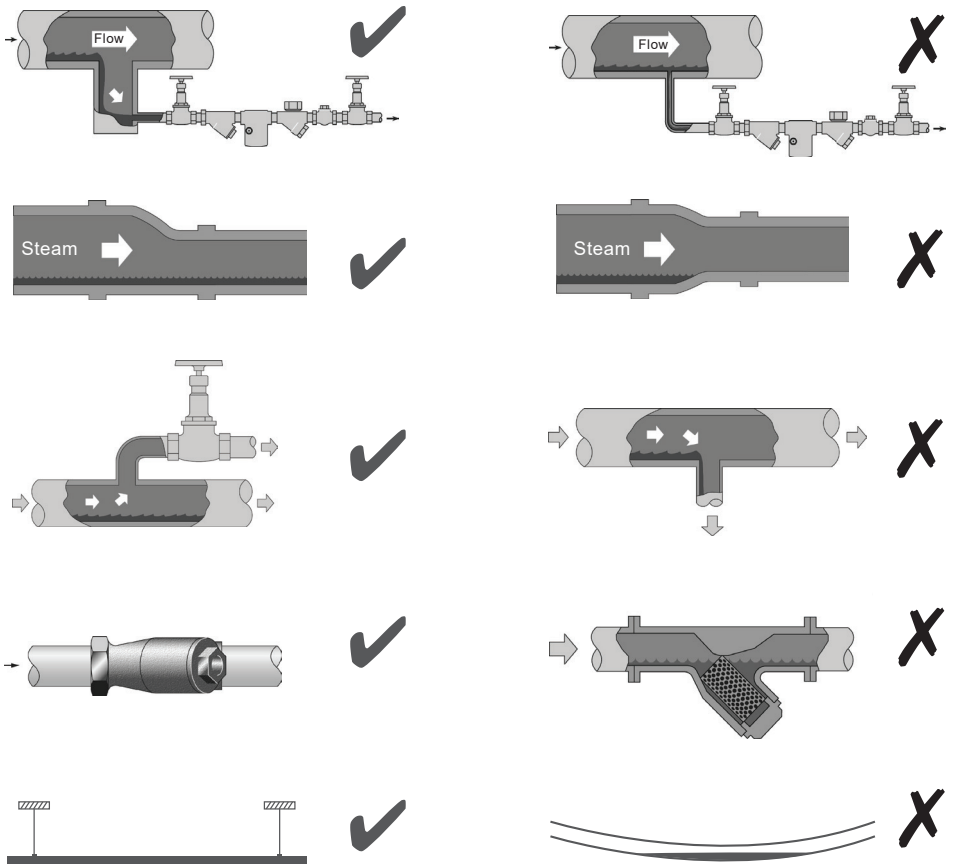

Prevention of tensile stressing

Pipe misalignment:

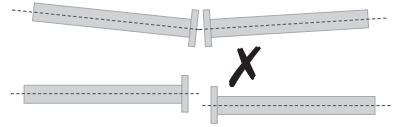
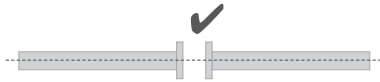

Installing products or re-assembling after maintenance:



Do not over tighten.
Use correct torque figures.

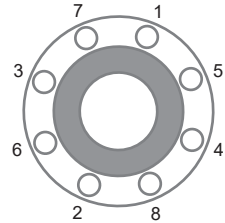
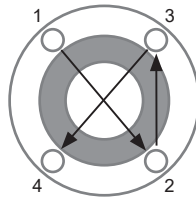

Flange bolts should be gradually tightened across diameters to ensure even load and alignment.

Thermal expansion:

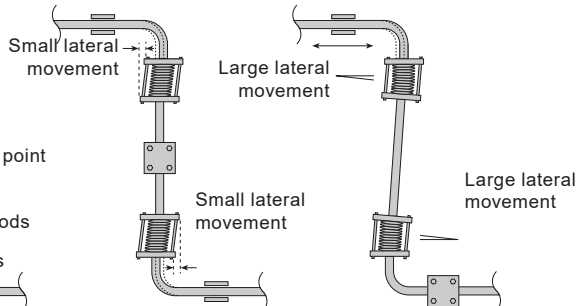
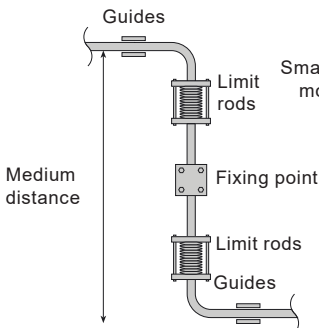
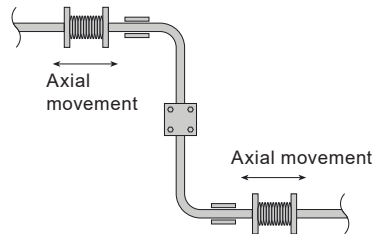
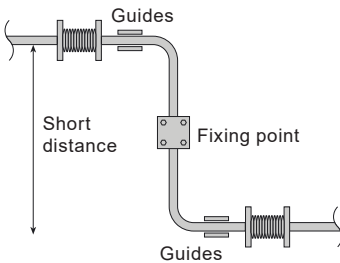

2. General product information

2.1 General description

The FT12 is a unique steam trap which utilises a large fixed orifice to handle very high condensate loads up to differential pressures of 4 bar (58 psi). An integral float trap mechanism provides a variable capacity in addition to the orifice. Minimum flowrates are required to avoid blowthrough and these depend on the orifice selected A, B, C or D.

The FT12 is manufactured in cast iron with DN150 (6") flanged connections. It is designed specifically for the sugar industry, which has inherently low pressure, high load steam systems.

Note: For additional information see the Technical Information Sheet T1-P020-01-EN-ISS1.

2.2 Size and pipe connections

DN150 flanged PN16 and ANSI 125 (Flanges to BS 10 Table D can be supplied to special order).

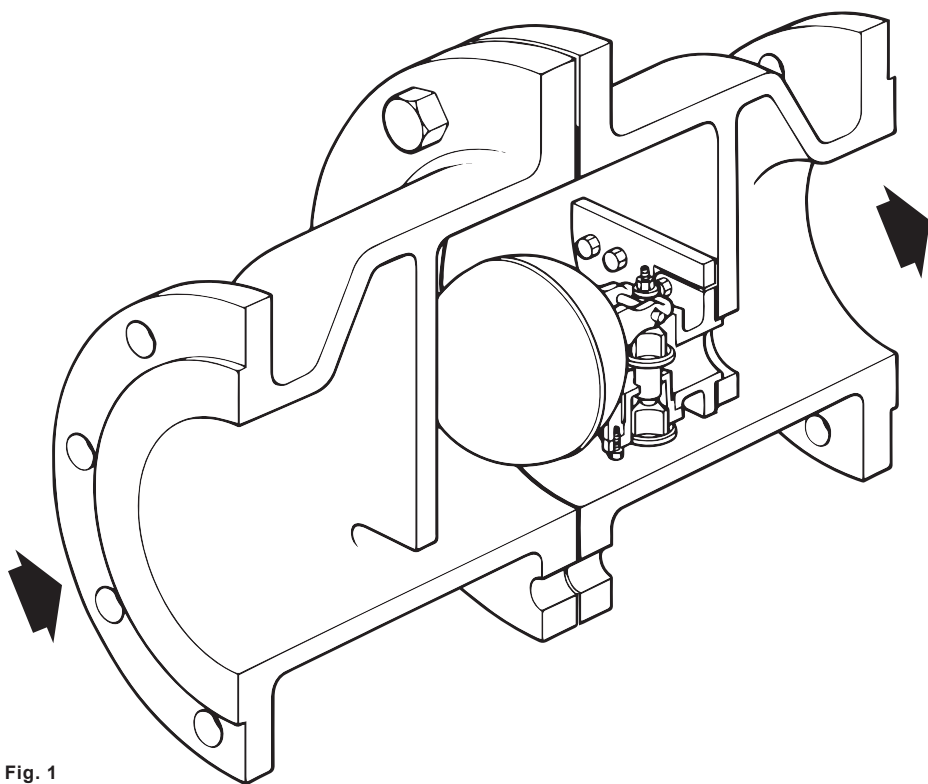
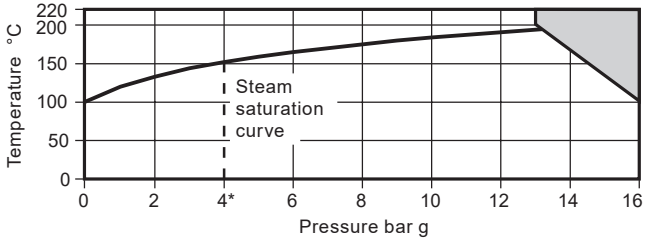

Fig. 1

2.3 Pressure/temperature limits



The product **must not** be used in this region.

*PMO Maximum operating pressure recommended for saturated steam 4 bar g (58 psi g).

Body design conditions			PN16
PMA	Maximum allowable pressure	4 bar g	(58 psi g)
TMA	Maximum allowable temperature	220 °C	(428 °F)
PMO	Maximum operating pressure	4 bar g	(58 psi g)
TMO	Maximum operating temperature	220 °C	(428 °F)
Designed for a maximum cold hydraulic test pressure of:		24 bar g	(348 psi g)

3. Installation

Note: Before actioning any installation observe the 'Safety information' in Section 1.

Referring to the Installation and Maintenance Instructions, name-plate and Technical Information Sheet, check that the product is suitable for the intended installation:

- 3.1** Check materials, pressure and temperature and their maximum values. If the maximum operating limit of the product is lower than that of the system in which it is being fitted, ensure that a safety device is included in the system to prevent overpressurisation.
- 3.2** Determine the correct installation situation and the direction of fluid flow.
- 3.3** Remove protective covers from all connections.
- 3.4** The trap is designed for installation in a horizontal plane. A typical installation is shown in Figure 2. Where air is present as part of the process cycle a separate thermostatic air vent can be fitted in parallel.

Note: If the trap is to discharge to atmosphere ensure it is to a safe place, the discharging fluid may be at a temperature of 100 °C (212 °F).

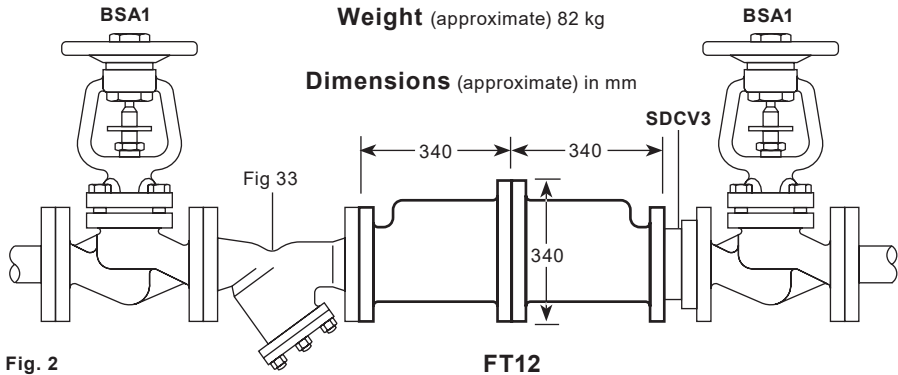

Fig. 2

4. Commissioning

After installation or maintenance ensure that the system is fully functional. Carry out tests on any alarms or protective devices.

5. Operation

5.1 General information

The ball float steam trap is a continuous discharge trap, removing condensate the instant it forms. On start-up, the addition of a thermostatic air vent (if required) allows air to bypass the main valve preventing the system air binding. Hot condensate will close the air vent tightly, but as soon as it enters the trap, the float rises and the lever mechanism attached to it opens the main valve - keeping the system drained of condensate at all times. When steam arrives, the float drops and closes the main valve. Float traps are renowned for their high start-up load handling capability, clean tight shut-off and resistance to waterhammer and vibration.

5.2 Trap operation

It is important that the FT12 is sized correctly to the running load of the plant being drained. See Technical Information Sheet TI-P020-01-EN-ISS1 for full details on 'Capacities - How to select/size the trap'.

The fixed orifice (available in four different cross sectional areas A, B, C, or D) will pass a set amount of condensate at any given differential pressure consequently it is important that loads are constant. If the condensate load drops below the minimum value shown then steam will also pass through the trap. A separate float trap mechanism provides additional capacity should the condensate level build up to the maximum value shown on the graph. Correct sizing will ensure that the plant condensate flow is between the minimum and maximum flowrates shown.

6. Maintenance

Note: Before actioning any maintenance programme observe the 'Safety information' in Section 1.

Warning

The cover gasket contains a thin stainless steel support ring which may cause physical injury if not handled and disposed of carefully.

6.1 How to fit the main valve assembly:

- Remove the trap from the pipeline, using a suitable spanner, withdraw the eight body bolts (2).
- Remove the main valve assembly, by unscrewing the four bolts (6).
- Withdraw the main valve assembly and replace with a new one.
- Replace bolts and tighten evenly.
- Replace cover gasket and tighten cover bolts to the recommended torque (see Table 1).

6.2 How to fit the orifice plate:

- Remove the trap from the pipeline, using a suitable spanner, withdraw the eight body bolts (2).
- Remove the main valve assembly, by unscrewing the four bolts (6), and the four bolts (9) which secure the orifice plate, and then remove.
- A new orifice plate should be fitted in the reverse order, and all screws tightened to the recommended torque (see Table 1).

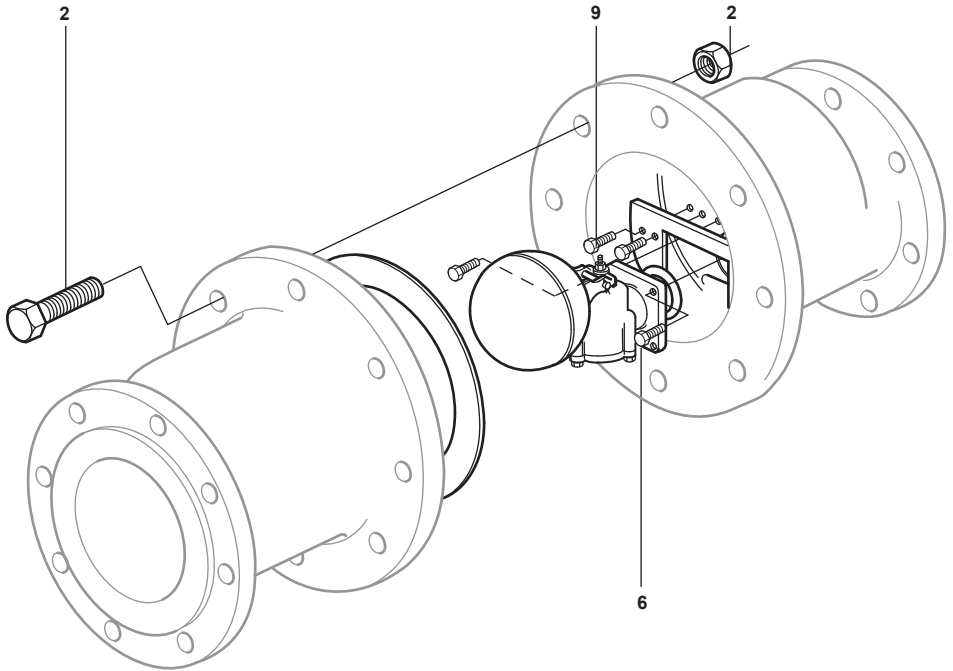



Table 1 Recommended tightening torques

Item	Part	 or  mm	N m	(lbf ft)
2	Cover bolts/nuts	32 A/F	M22 x 90	160 - 180 (117 - 132)
6	Main valve assembly bolts		M8 x 20	20 - 24 (15 - 17)
9	Orifice plate bolts		M8 x 20	20 - 24 (15 - 17)

7. Spare parts

The spare parts available are shown in heavy outline. Parts drawn in a grey line are not supplied as spares.

Available spares

Main valve assembly with float	4, 5, 6, 7, 8
Orifice plate (state A, B, C or D)	8, 9
Set of body gaskets (packet of 3)	3
Set of body nuts and bolts	2

How to order spares

Always order spares by using the description given in the column headed 'Available spares' and state the size and type of trap.

Example: 1 - Main valve assembly for DN150 FT12-D float trap.

