

EasiHeat Mechanical Installation and Commissioning Instructions

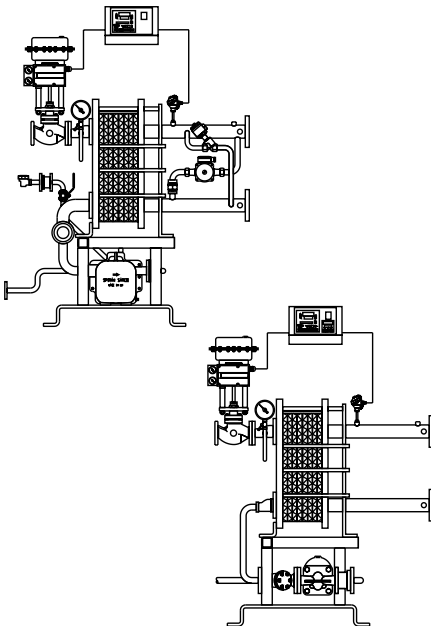

1. *General safety information*
2. *General product information*
3. *Installation*
4. *Commissioning*
5. *Operation*
6. *Maintenance*

1. General safety information

Note: This document refers only to the mechanical installation and commissioning of the EasiHeat unit and should be used in conjunction with the relevant IMIs for the other system components and supplementary safety information for all the system components.

Warning

Your attention is drawn to Safety Information Leaflet IM-GCM-10, as well as to any National or Regional regulations.

This product is designed and constructed to withstand the forces encountered during normal use.

Use of the product for any purpose other than its intended use could cause damage to the product and may cause injury or fatality to personnel.

Before any installation or maintenance procedure, always ensure that all primary steam and condensate return lines and secondary water lines are isolated.

Ensure any residual internal pressure in the system or connecting pipework is carefully relieved.

Allow hot parts to cool before commencing work, to avoid the risk of burns.

Always wear appropriate safety clothing before carrying out any installation or maintenance work.

Lifting

The EasiHeat unit should be lifted by a suitable forklift truck, from the base, placed in position and securely bolted to the floor. Note:

- On no account is the EasiHeat unit to be lifted by any other part, other than the base.
- Sufficient space should be provided in its location to allow access for maintenance.
- The core unit occupies a maximum of 1.2 m³ space (maximum footprint of 955 x 719 mm).

The full package option occupies a maximum of 3.55 m³ (maximum footprint of 1 830 x 1 133 mm).

— 2. General product information —

2.1 General information

EasiHeat systems use steam to provide accurate heating of low temperature hot water (HTG), domestic hot water (DHW) or hot water for processes. Systems can be sized for any heating duty from 100 kW to approximately 1.2 MW and are supplied fully assembled and pressure tested, ready for installation.

The EasiHeat base unit provides the core of the system, while options 1 to 6 (see Section 2.2) include additional features such as: high limit package, stop valve package and separator package variants.

The EasiHeat unit consists of the following core items (refer to Figure 1):

- Steam plate heat exchanger, type TS6-M.
- Pneumatic or electrically actuated steam control valve and positioner.
- Controller and sensor.
- Condensate removal solution (either a float trap or an automatic pump trap).
- Ancillaries.

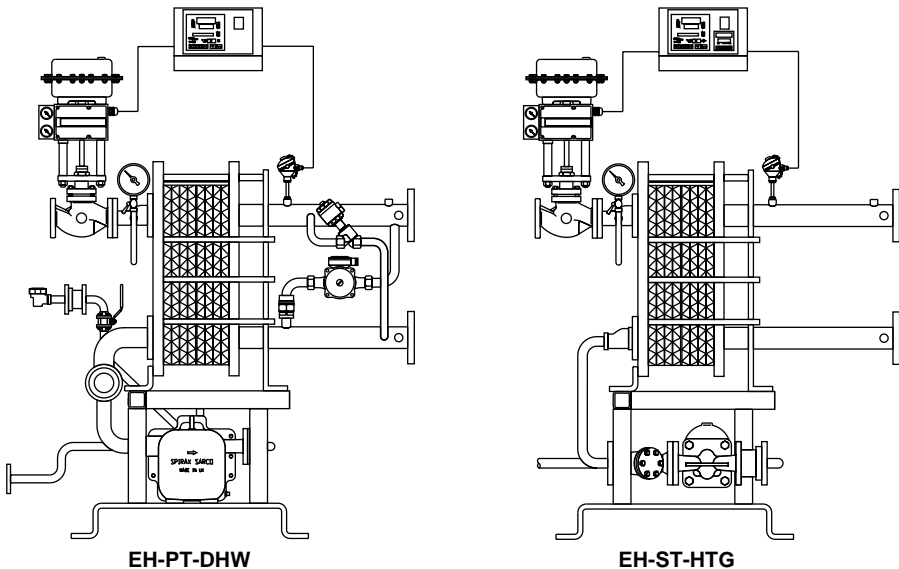

Note: For additional information about any particular product used in the construction of this unit see the relevant Technical Information Sheet.

Fig. 1

2.2 Identification

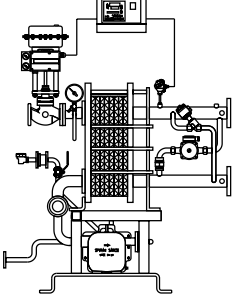

The unit is available in the following package options:

Note: Depending upon the operating conditions of the package the plate heat exchanger gasket will either be manufactured from EPDM or HeatSeal.

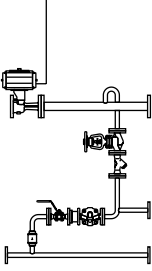
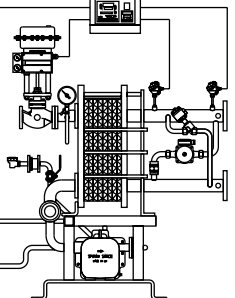

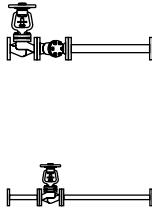
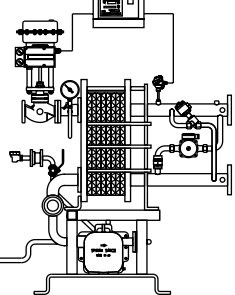
<p>Option 1 - Basic unit</p>	<p>Basic unit</p> 
<p>Nomenclature:</p> <p>EH- - - - - - - - - - -</p> <p>Basic EasiHeat unit with either pneumatic control valves or electric control valves.</p>	

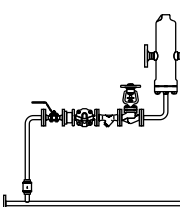
<p>Option 2 - High limit package</p>	<p>High limit option</p> 	<p>Basic unit</p> 
<p>Nomenclature:</p> <p>EH- - - - - - - - - - -HL</p> <p>A pneumatic or electrically actuated, fail-safe high limit function, automatically isolating steam if a pre-set secondary temperature is reached.</p>		

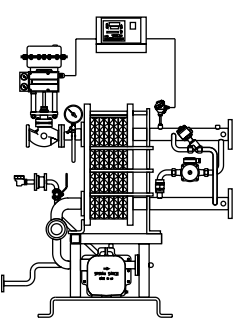
<p>Option 3 - Stop valve package</p>	<p>Stop valve set</p> 	<p>Basic unit</p> 
<p>Nomenclature:</p> <p>EH- - - - - - - - - - -V</p> <p>Bellows sealed stop valves fitted to the steam inlet and condensate outlet connections, to enable isolation of the primary circuit, together with a strainer to protect the temperature control valve.</p>		

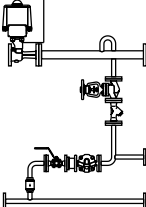
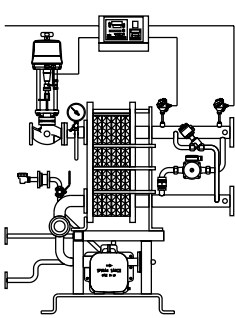
<p>Option 4 - Stop valve and separator package</p>	<p>Separator set</p>	<p>Stop valve set</p>	<p>Basic unit</p>
<p>Nomenclature: EH- - - - - - - - -VS</p> <p>The stop valve package together with a separator set ensures dry saturated steam is delivered to the EasiHeat unit.</p>			

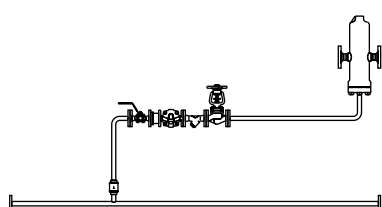
<p>Option 5 - High limit option and stop valve package</p>	<p>Stop valve set</p>	<p>High limit option</p>	<p>Basic unit</p>
<p>Nomenclature: EH- - - - - - - - -HL-V</p> <p>Both the high limit option and the stop valve set, combined into one package.</p>			

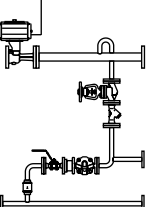
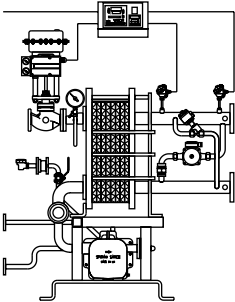
<p>Option 6 - Full option package</p>			
<p>Nomenclature: EH- - - - - - - - -HL-VS</p>			
<p>A combination of all the available options to provide a fully specified EasiHeat package.</p>			
<p>Separator set</p> 	<p>Stop valve set</p> 	<p>High limit option</p> 	<p>Basic unit</p> 

3. Installation

Warning: Before proceeding with any installation or maintenance work read Section 1, Safety information.

3.1 Steam and condensate connections

It is important that the steam supply to the EasiHeat unit is supplied as dry and as clean as possible, in accordance with good steam engineering practice.

It should also be ensured that all connecting pipework is stress free and adequately supported. The steam supply should always be maintained at the specified design pressure and temperature for the unit. The EasiHeat must not operate above the maximum steam pressure and temperature indicated on the name-plate attached to the heat exchanger.

The installation of an appropriately sized safety valve, to protect any lower pressured equipment on either the primary or secondary side of the heat exchanger, is strongly recommended.

Spirax Sarco supply a range of traps, strainers, separators, safety valves and pressure reducing equipment.

3.2 Air supply

If a pneumatic control system is installed, connect a compressed air supply (4.5 to 8 bar g) to the pressure regulator mounted on the control valve.

3.3 Electrical supply

All electrical wiring and connections should be carried out in accordance with National regulations and Standards.

Electrical supply :

Actuator type	Power supply	Supply fuse	Bypass pump	Actuators / solenoid valve
- PN	230 Vac/50 Hz	13A (T)	230 Vac/50 Hz	230 Vac/50 Hz
- EL1	230 Vac/50 Hz	13A (T)	230 Vac/50 Hz	230 Vac/50 Hz
- EL2	115 Vac/50 Hz	13A (T)	N/A - HTG only	115 Vac/50 Hz
- EL3	230 Vac/50 Hz	13A (T)	230 Vac/50 Hz	24 Vac/50 Hz

- A lockable isolator / switch disconnecter should be fitted adjacent to the unit.

4. Commissioning

We recommend the service and support of a Spirax Sarco Commissioning Engineer.
Details of this service can be found by contacting Spirax Sarco.

Note: In most new installations, dirt collects in the steam line during construction of piping systems. It is essential to flush this out prior to commissioning.

Commissioning procedure:

- **Check all** electrical connections are secure and as per installation drawing.
- **Dry commissioning valve stroke check** - An initial valve stroke check should be carried out to ensure free movement of the valve stem.
- **Shut** steam inlet valve upstream of the EasiHeat.
- **Open** all condensate drain valves.
- **Switch off** electrical power.
- **Open** secondary isolating valves downstream of the EasiHeat.
- **Start** the main secondary water circulating pump(s) if fitted.
- **Check** for secondary water circulation through the EasiHeat.
- **If the circulation is okay, switch on** the power to the unit (local isolator), first ensuring that the voltage and frequency are correct.
- **Switch on** the main switch, (rocker switch adjacent to the controller).
- **If an SX100 controller** is fitted select the required program (e.g. 2 for constant).

Note: ensure the temperature setting is suitable for the application. If this needs to be altered, refer to the 'Controller Quick Set-up Manual'.

- **Slowly open** main steam inlet valve.
- **Check** process temperature is within the acceptable limits of the set point and that the bypass pump, if fitted, is running.

Important - high limit setting:

- **If fitted, the high limit controller** should be set at a suitable level to protect plant, process and personnel. Details of setting can be found in the separate high limit controller IMI. Care should be taken to ensure sufficient difference between the process set point and the high limit set point, to avoid any unwanted high limit tripping.
- **Check** temperature rises to set value and controls satisfactorily.
- **If necessary adjust PID settings**, (see DB-S27-08, 'Selecting PID settings').
We would strongly recommend that only a suitably trained controls engineer adjust these parameters.
- **Check** operation of steam traps/condensate pump.

The EasiHeat unit is now ready for service

5. Operation

The steam flowrate is modulated to match the heat demand. The control valve is either pneumatically or electrically actuated and the system uses a rapid response Pt100 temperature sensor and programmer / controller for the precise control. The pumping trap version can operate at low or even sub-atmospheric steam pressure, in areas where there is a risk of scaling of the heat exchanger in open circuit installations such as a domestic hot water application.

The EasiHeat is designed for the following applications, avoiding the requirement for large storage vessels:

Low temperature hot water (LTHW, $\Delta T < 25^{\circ}\text{C}$): Accurate temperature control is achieved whatever the heating load requirements. The response to load changes for heating circuits is excellent.

Domestic hot water (DHW, $\Delta T > 25^{\circ}\text{C}$): The Easiheat will deliver a constant stable temperature, even with the sudden and wide load changes often found in domestic hot water applications.

Process heating: A wide range of duties can be satisfied. Low pressure primary operation is available for temperature sensitive fluids.

6. Maintenance

General

For maintenance of the individual components of the system, please see the relevant IMI's for the products concerned.

High limit device testing

The purpose of the test is to ensure the system operates satisfactorily when required to do so.

Method

1. High limit set point test

The set point of the high limit controller should be lowered, to simulate a high temperature situation. Test personnel should ensure the high limit device operates in a satisfactory manner.

2. Electrical power failure test

The unit should be switched off at the controller rocker switch to simulate power failure. Examination should be made to ensure the high limit system has switched to its fail-safe mode, isolating the primary steam supply.

Frequency

It is essential that a competent person tests the high limit device on a frequent basis. Intervals between tests should not exceed a six month period.

We do not recommend the installation of a self-acting high limit system to the Easiheat package.

Scale formulation

Within open systems, where there is continual make-up water, there is a risk of scale formation. The extent of the scale will depend largely upon the water quality, which varies greatly from area to area. A test, conducted by a water treatment specialist, is recommended to determine the local quality and whether problems are foreseen.

After extended service, the plate heat exchanger can be easily dismantled for cleaning. If scale becomes a persistent problem, regular chemical cleaning should be considered. $\frac{3}{4}$ " ports are available on the secondary inlet and outlet piping to allow easy connection for 'Clean in Place' apparatus.

It should be noted that raising the steam pressure could result in an increase of scaling.