

**CS10-1 Stainless Steel
Clean Steam Separator**
Installation and Maintenance Instructions

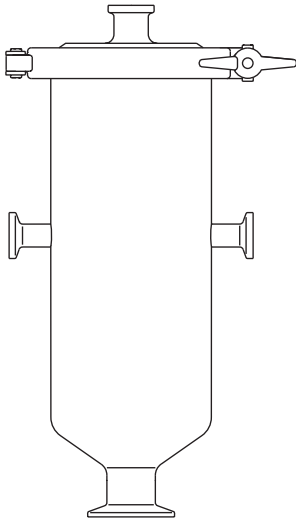

1. Safety information
2. General product information
3. Installation
4. Commissioning
5. Operation
6. Maintenance
7. Spare parts

1. Safety information

Safe operation of this product can only be guaranteed if it is properly installed, commissioned, used and maintained by qualified personnel (see Section 1.11) in compliance with the operating instructions. General installation and safety instructions for pipeline and plant construction, as well as the proper use of tools and safety equipment must also be complied with.

1.1 Intended use

Referring to the Installation and Maintenance Instructions, body markings and Technical Information Sheet, check that the product is suitable for the intended use/application. The product listed below complies with the requirements of the EU Pressure Equipment Directive/UK Pressure Equipment

(Safety) Regulations and carries the  mark when so required.

| Product | | Group 1 Gases | Group 2 Gases | Group 1 Liquids | Group 2 Liquids |
|---------|------------------------|---------------|---------------|-----------------|-----------------|
| CS10-1 | DN15 - DN25 (½" - 1") | - | SEP | - | SEP |
| | DN40 - DN50 (1½" - 2") | - | 1 | - | SEP |

- i) This product has been specifically designed for use on steam, air or water/condensate which is in Group 2 of the above mentioned Pressure Equipment Directive. The products' use on other fluids may be possible but, if this is contemplated, Spirax Sarco should be contacted to confirm the suitability of the product for the application being considered.
- ii) Check material suitability, pressure and temperature and their maximum and minimum values. If the maximum operating limits of the product are lower than those of the system in which it is being fitted, or if malfunction of the product could result in a dangerous overpressure or overtemperature occurrence, ensure a safety device is included in the system to prevent such over-limit situations.
- iii) Determine the correct installation situation and direction of fluid flow.
- iv) Spirax Sarco products are not intended to withstand external stresses that may be induced by any system to which they are fitted. It is the responsibility of the installer to consider these stresses and take adequate precautions to minimise them.
- v) Remove protection covers from all connections and protective film from all name-plates, where appropriate, before installation on steam or other high temperature applications.

1.2 Access

Ensure safe access and if necessary a safe working platform (suitably guarded) before attempting to work on the product. Arrange suitable lifting gear if required.

1.3 Lighting

Ensure adequate lighting, particularly where detailed or intricate work is required.

1.4 Hazardous liquids or gases in the pipeline

Consider what is in the pipeline or what may have been in the pipeline at some previous time. Consider: flammable materials, substances hazardous to health, extremes of temperature.

1.5 Hazardous environment around the product

Consider: explosion risk areas, lack of oxygen (e.g. tanks, pits), dangerous gases, extremes of temperature, hot surfaces, fire hazard (e.g. during welding), excessive noise, moving machinery.

1.6 The system

Consider the effect on the complete system of the work proposed. Will any proposed action (e.g. closing isolation valves, electrical isolation) put any other part of the system or any personnel at risk? Dangers might include isolation of vents or protective devices or the rendering ineffective of controls or alarms. Ensure isolation valves are turned on and off in a gradual way to avoid system shocks.

1.7 Pressure systems

Ensure that any pressure is isolated and safely vented to atmospheric pressure. Consider double isolation (double block and bleed) and the locking or labelling of closed valves. Do not assume that the system has depressurised even when the pressure gauge indicates zero.

1.8 Temperature

Allow time for temperature to normalise after isolation to avoid the danger of burns and consider whether protective clothing (including safety glasses) is required.

If the sanitary clamp seal (which is made from PTFE encapsulated Viton) has been subjected to a temperature approaching 250 °C (482 °F) or higher, it will give off toxic fumes, which if inhaled are likely to cause temporary discomfort. It is essential for a NO SMOKING rule to be enforced in all areas where PTFE is stored, handled, or processed as persons inhaling the fumes from burning tobacco contaminated with PTFE particles can develop 'polymer fume fever'.

If the sanitary clamp seal has been subjected to a temperature approaching 315 °C (599 °F) or higher, the Viton may have decomposed and formed hydrofluoric acid. Avoid skin contact and inhalation of any fumes as the acid will cause deep skin burns and damage to the respiratory system.

1.9 Tools and consumables

Before starting work ensure that you have suitable tools and/or consumables available. Use only genuine Spirax Sarco replacement parts.

1.10 Protective clothing

Consider whether you and/or others in the vicinity require any protective clothing to protect against the hazards of, for example, chemicals, high/low temperature, radiation, noise, falling objects, and dangers to eyes and face.

1.11 Permits to work

All work must be carried out or be supervised by a suitably competent person. Installation and operating personnel should be trained in the correct use of the product according to the Installation and Maintenance Instructions.

Where a formal 'permit to work' system is in force it must be complied with. Where there is no such system, it is recommended that a responsible person should know what work is going on and, where necessary, arrange to have an assistant whose primary responsibility is safety.

Post 'warning notices' if necessary.

1.12 Handling

Manual handling of large and/or heavy products may present a risk of injury. Lifting, pushing, pulling, carrying or supporting a load by bodily force can cause injury particularly to the back. You are advised to assess the risks taking into account the task, the individual, the load and the working environment and use the appropriate handling method depending on the circumstances of the work being done.

1.13 Residual hazards

In normal use the external surface of the product may be very hot. If used at the maximum permitted operating conditions the surface temperature of some products will exceed temperatures of 250 °C (482 °F).

Many products are not self-draining. Take due care when dismantling or removing the product from an installation (refer to 'Maintenance instructions').

1.14 Freezing

Provision must be made to protect products which are not self-draining against frost damage in environments where they may be exposed to temperatures below freezing point.

1.15 Disposal

The product is recyclable. No ecological hazard is anticipated with the disposal of this product providing due care is taken, except:

Viton:

- Can be land filled, when in compliance with National and Local regulations.
- Can be incinerated, but a scrubber must be used to remove Hydrogen Fluoride, which is evolved from the product and with the compliance of National and Local regulations.

1.16 Returning products

Customers and stockists are reminded that under EC Health, Safety and Environment Law, when returning products to Spirax Sarco they must provide information on any hazards and the precautions to be taken due to contamination residues or mechanical damage which may present a health, safety or environmental risk. This information must be provided in writing including Health and Safety data sheets relating to any substances identified as hazardous or potentially hazardous.

2. General product information

2.1 Description

The CS10-1 clean steam separator has been designed in full accordance with the ASME BPE guide to overcome the issues of removing entrained moisture from clean and pure steam systems. It has also been designed with the feature of a removable baffle plate, allowing the unit to be fully inspected prior to installation and to facilitate system internal inspection.

Standard surface finish

| | |
|-----------------|---|
| Internal | 0.5 µm (20 micro-inch) Ra maximum/SF5 - as outlined in ASME BPE, with all welds ground and electropolished. |
|-----------------|---|

| | |
|-----------------|--|
| External | 1.6 µm Ra maximum, with a satin bead blast finish. |
|-----------------|--|

Standards

This product has been designed in accordance with the latest standard of the ASME BPE guide. It also complies with the requirements of the EU Pressure Equipment Directive/UK Pressure Equipment (Safety) Regulations. All polymers used comply with FDA regulation CFR 21 paragraph 177 section 2600. ½", ¾" and 1" sizes are available with USP class VI.

Certification

This product is available with the following certification:

- EN 10204 3.1 material certifications.
- Certificate of conformity including internal surface finish.
- Certification of polymers FDA/USP compliance (the polymers for the 1½" and 2" sizes are FDA approved only).

Note: All certification/inspection requirements must be stated at the time of order placement.

Packaging

Packaging for this product is conducted in a clean environment, segregated from other non stainless steel products, and in accordance with ASME BPE for optimum protection and cleanliness; The inlet and outlet connections of the product are fitted with protective caps before being sealed with shrink wrap.

Note: For additional information see Technical Information Sheet TI-P023-59.

2.2 Sizes and pipe connections

| | |
|-------------------------------|---|
| Steam inlet and outlet | ½", ¾", 1", 1½" and 2" sanitary clamp ASME BPE (Sanitary Clamp) or DIN 32676 upon request. Extended Tube Weld ends (ETO) ASME BPE or DIN 11850 upon request. |
| Drain | 1" ASME BPE (Sanitary Clamp) |
| Vent | ½" ASME BPE (Sanitary Clamp) |

Note: Other connections are available upon request.

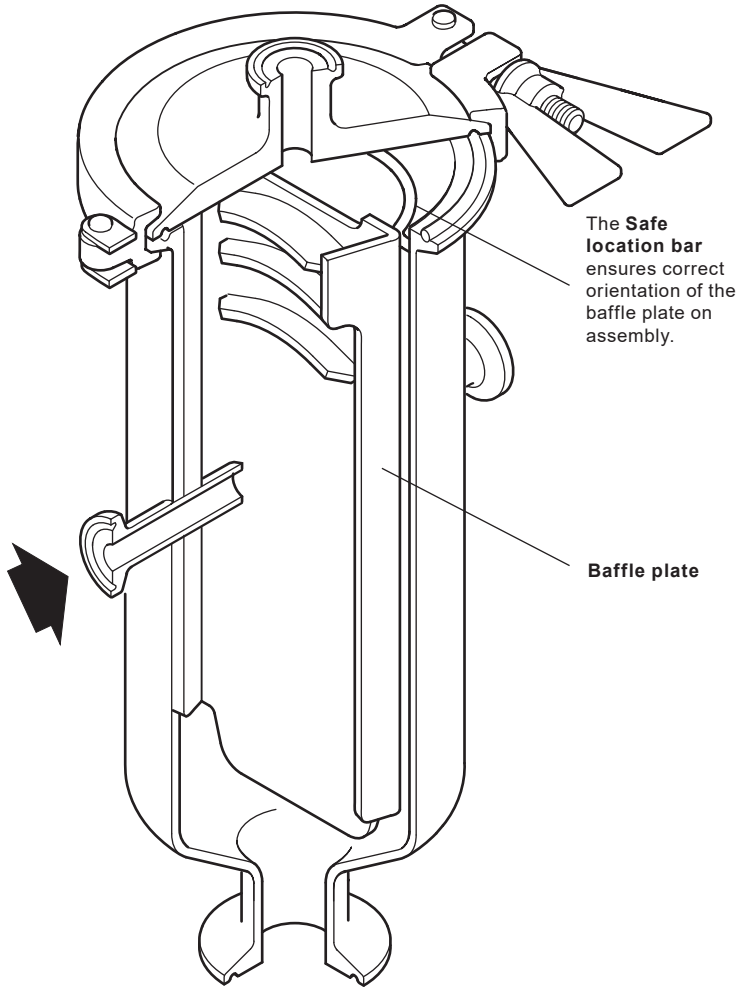
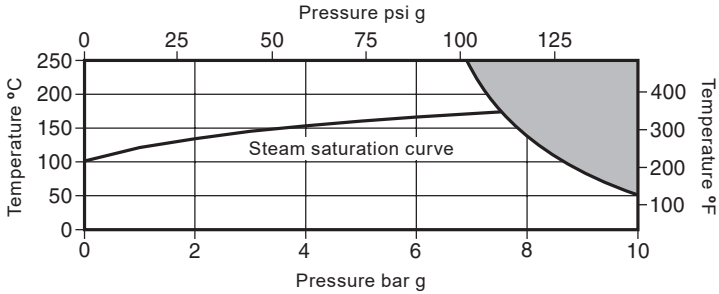

Fig. 1 CS10-1

2.3 Pressure/temperature limits (ISO 6552)



The product **must not** be used in this region.

Note: For hygienic/sanitary clamp ends the maximum pressure/temperature may be restricted by the gasket or sanitary clamp used. Please consult Spirax Sarco.

| | | |
|------------------------|---|--|
| Body design conditions | | PN10 |
| PMA | Maximum allowable pressure | 10 bar g @ 50 °C (145 psi g @ 122 °F) |
| TMA | Maximum allowable temperature | 250 °C (482 °F) |
| | Minimum allowable temperature | -10 °C (14 °F) |
| PMO | Maximum operating pressure for saturated steam service | 7.6 bar g (110 psi g) |
| TMO | Maximum operating temperature | 250 °C @ 6.8 bar g (482 °F @ 98 psi g) |
| | Minimum operating temperature | 0 °C (32 °F) |
| | Designed for a maximum cold hydraulic test pressure of: | 15 bar g (217 psi g) |

3. Installation

Note: Before actioning any installation observe the 'Safety information' in Section 1.

Important installation note:

Install in a horizontal pipeline with the drain directly below.

To ensure that any separated liquid is drained away quickly, a suitable liquid drainer or steam trap must be connected to the drain.

Referring to the Installation and Maintenance Instructions, name-plate and Technical Information Sheet, check that the product is suitable for the intended installation:

- 3.1** Check materials, pressure and temperature and their maximum values. If the maximum operating limit of the product is lower than that of the system in which it is being fitted, ensure a safety device is included in the system to prevent overpressurisation.
- 3.2** Determine the correct installation situation and the direction of fluid flow.
- 3.3** Remove protective covers from all connections and the protective film from all name-plates, where appropriate, before installation on steam or other high temperature applications.
- 3.4** The separators may be lagged if required.
- 3.5** Install in a horizontal pipeline with the drain directly below.
To ensure that any separated liquid is drained quickly, a suitable liquid drainer or steam trap must be connected to the drain connection. A float type trap is recommended.
For those steam systems where air can be present, air can collect in the upper portion of the separator. In this situation a suitable air vent should be connected to the air vent connection.
If an air vent is not being fitted then the connection must have the plastic transit protection plug removed and must have an ASME BPE/BS 4825 sanitary clamp fitted.

Notes: The body must be handled carefully to ensure that the machined surfaces are not damaged.

4. Commissioning

After installation or maintenance ensure that the system is fully functioning. Carry out tests on any alarms or protective devices.

Note: If installed on a steam/condensate system, it is very important that the pressure is built up slowly to avoid possible damage to the unit.

5. Operation

Separators are designed to gather together small droplets of entrained liquids and then separate them from the gas/vapour flow. The relatively heavy droplets impinge on the internal baffles and are then directed to the separator drain connection and removed from the system using a steam trap, or when used on air or gas distribution system, a liquid drainer.

6. Maintenance

Note: Before actioning any maintenance programme observe the 'Safety information' in Section 1.

Before undertaking any maintenance on the separator it must be isolated from the supply line and return line and any pressure allowed to slowly normalise to atmosphere. The separator should then be allowed to cool.

Note: The body and internal parts must be handled carefully to ensure that the machined surfaces are not damaged.

Remove sanitary clamps. The cover with baffle plate and seal can then be removed for cleaning or replacement. Reassemble using a new seal. Whenever the cover is disassembled, the seal is to be changed with a new one. Replace and tighten sanitary clamps and put back into service. Check for leaks and retighten as necessary.

Note: The Safe location bar (Refer to Figure 1) ensures correct orientation of the baffle plate on assembly.

Note: Minimum service interval of the seal is 1 year.

7. Spare parts

Spare parts are available as indicated. No other parts are supplied as spares.

Available spares

| | |
|-------|---|
| Seal | 3 |
| Clamp | 4 |

How to order spares

Always order spares by using the description given in the column headed 'Available spares' and state the size, model number and pressure rating of the trap.

Example: 1 off Seal for a Spirax Sarco 1½" CS10-1 stainless steel clean steam separator.

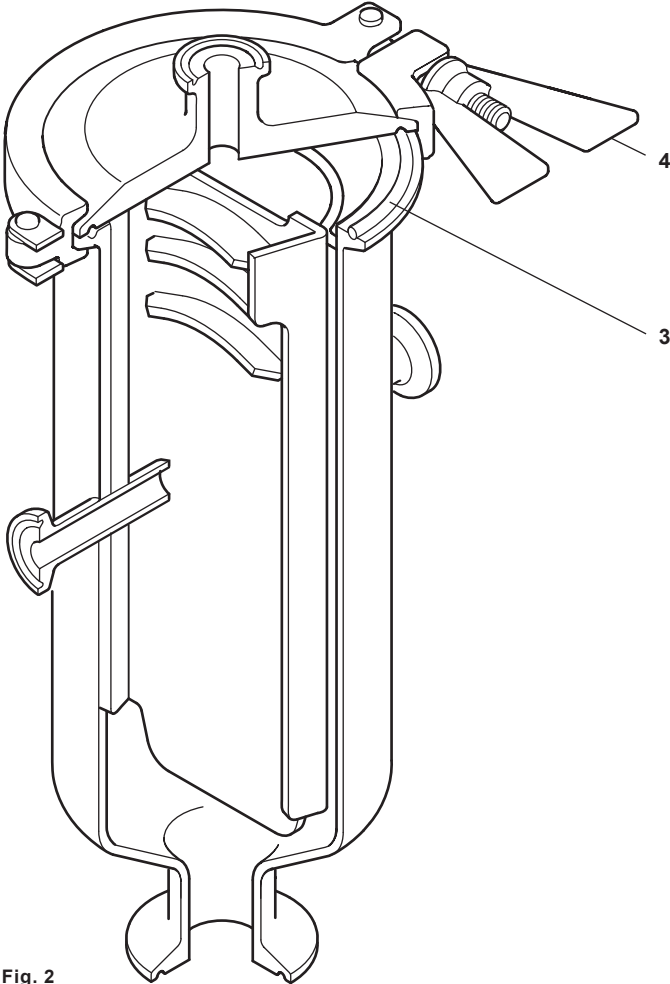

Fig. 2

CS10-1 Stainless Steel Clean Steam Separator

