

# spirax/sarco®

## HP45 Bimetallic Steam Trap

### Description

Spirax Sarco's HP45 bimetallic steam traps are made of forged steel, and designed for draining high pressure, high temperature steam lines and processes.

These steam traps, which are specially designed for HP steam, have a reinforced stainless steel insert within the body and can be repaired inline. They operate with no loss of steam, and quickly drain air, non-condensable gases and large quantities of cold water on start-up.

Normally open in the event of failure, they have a check valve, a built-in strainer screen and an external device for adjusting the discharge temperature of the condensate.

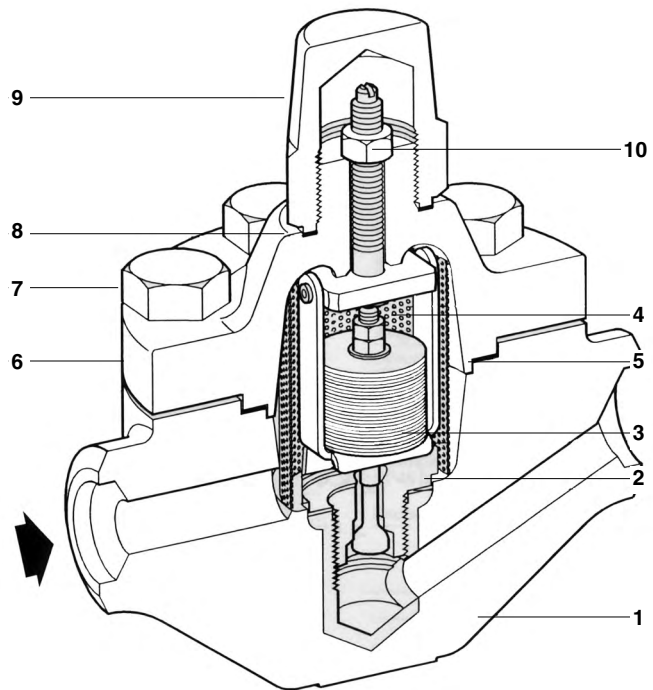

### Sizes and pipe connections

1/2", to 1" screwed BSP/NPT and socket weld ends (ANSI B 16.11)  
3/4" and 1" with ANSI 600 flanges

### Limiting Conditions

Body design conditions	PN150, Class 900 to ANSI B 16.34	
PMO - Maximum operating pressure	652 psig	45 barg
TMO - Maximum operating temperature	842°F	450°C
Minimum operating pressure	217 psig	15 barg
ΔPMX - The back pressure for correct operation must not exceed 90% of the upstream pressure.		
Designed for maximum cold hydraulic test pressure of 3320 psig 229 barg		

### Materials

No.	Part	Material
1	Body	Steel ASTM A105 Gr.II or equivalent
2	Valve seat gasket	Stainless steel AISI 304
3	Bimetallic element	Stainless steel
4	Strainer screen	Stainless steel AISI 304L
5	Cover gasket	Metal, copper/graphite (asbestos-free)
6	Cover	Steel ASTM A105 or equivalent
7	Cover bolt	Steel
8	Blind nut gasket	Metal, copper/graphite (asbestos-free)
9	Blind nut	Steel ASTM A105 or equivalent
10	Lock-nut	Steel

### Certification

This product is available with certification to EN 10204 3.1.B  
All certificates must be requested at the time of ordering.

# HP45 Bimetallic Steam Trap

**Dimensions/weights** (approximate) in mm and kg

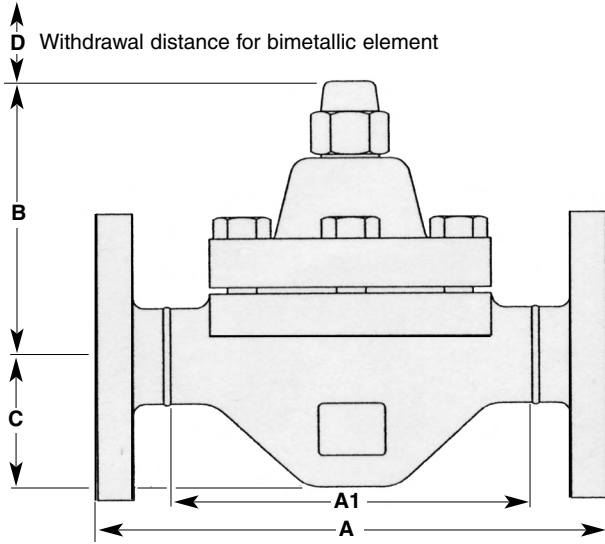

Size	A	A1	B	C	D	Weight
1/2"		6.3" 160	4.9" 124	2.3" 58	5.9" 150	17.6 lb. 8.0
3/4"		6.3" 160	4.9" 124	2.3" 58	5.9" 150	17.6 lb. 8.0
1"	9.25" 235	6.3" 160	4.9" 124	2.3" 58	5.9" 150	17.6 lb. 8.0
3/4"	9.25" 235	6.3" 160	4.9" 124	2.3" 58	5.9" 150	22.0 lb. 10.0
	DN20 ANSI 600					
1"	9.25" 235	6.3" 160	4.9" 124	2.3" 58	5.9" 150	23.2 lb. 10.5
	DN25 ANSI 600					

## Installation and maintenance

Full Installation and Maintenance Instructions (Inclusive of operation and fault finding) are supplied with the product, see IMI

## How to order

**Example:** 1 of 1/2" Spirax Sarco 'BYVAP' HP45 bimetallic steam trap with socket weld end connections.

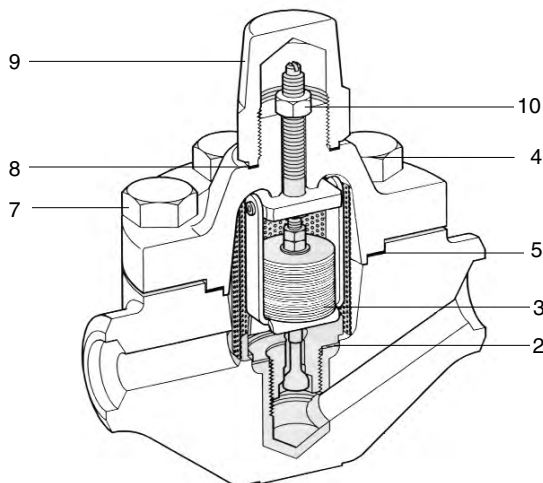

## Capacities

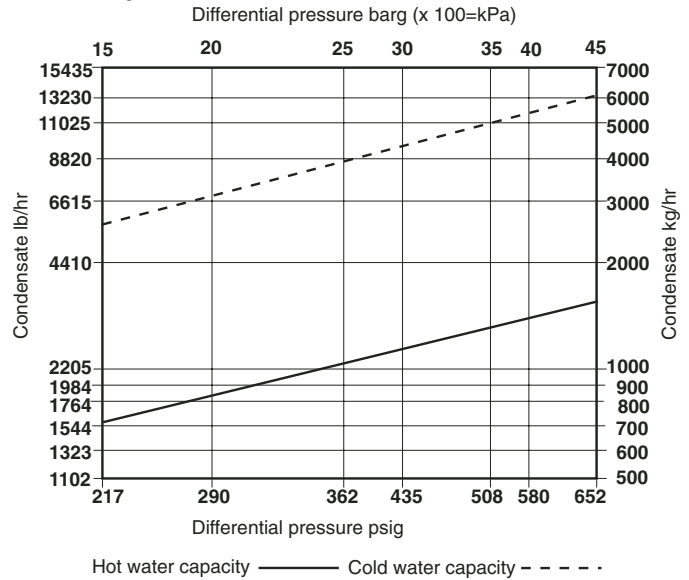

## Spare Parts

The spare parts available are detailed below. No other parts are supplied as spares.

### Available spare

Bimetallic assembly kit 2, 3, 4, 5, 8

## How to order spares

Always order spares by using the description given in the column headed 'Available spare' and state the size and model of the bimetallic steam trap.

**Example: 1** — Bimetallic assembly kit for a 1" Spirax Sarco 'BYVAP' HP45 bimetallic steam trap.

## Recommended tightening torques

Item	mm	Ft. / Lbs.
3	36 A/F	88.51
7	22 A/F	59.0
9	24 A/F	59.0
10	24 A/F	118