

LC 2610 Level Controller

- Modulating (or on/off) control of boiler water level using a capacitance probe
- Alpha-numeric display and push button control for straightforward commissioning
- Provides level control, two alarms, and a 4 - 20 mA output
- Single, two, or three element control in a single unit
- For use with electric or pneumatic control valve

Description

The Spirax Sarco LC2610 is a panel mounted level controller which provides:-

- Modulating or on/ off water level control using a capacitance probe.
- Two level alarms, high and low.
- 4 - 20 mA transmitter or control output.
- Single element control using a capacitance level probe.
- Two (or three) element control using a steam meter (and a water meter).
- Will also operate with a 4 - 20 mA level input, loop or externally powered.

It has switch selectable dual voltage (115/ 230 V), and is commissioned and operated using the buttons on the front panel.

The unit also has:-

- A security code to prevent unauthorised changes to the operating parameters.
- Selectable, adjustable alarm delay for differing turbulence conditions.
- Selectable 'alarm on loss of input signal'.
- Selectable 'alarm lockout' option.

An optional front cover is available for the LC2610.

Applications

Typical applications are:-

Level control

- Modulating level control using an electrically actuated valve. Feedback by potentiometer in actuator or via water meter.
- Modulating control using a pneumatically or electrically actuated valve with 4 - 20 mA positioner.
Note: As there is only one 4 - 20 mA output, if 4 - 20 mA is used for control, the transmitter output is not available.
- Two element level control - set point is raised corresponding to the rise in output of a steam meter.
- Three element level control - as two element system, but with the addition of a water meter so that the feedwater valve flow is controlled rather than the valve position.
- On/ off control of a pump (e.g. boiler feedpump) via a contactor.
- On/ off control using an electrically actuated valve (or pneumatically actuated valve with solenoid valve).

Level indication

Boiler water level is indicated on the LC2610 as a percentage of the boiler gauge glass. The 4 - 20 mA transmitter output may be used for remote signalling of the water level.

Note: As there is only one 4 - 20 mA output, if 4 - 20 mA is used for control, the transmitter output is not available.

Level alarm

- High alarm and low alarm.

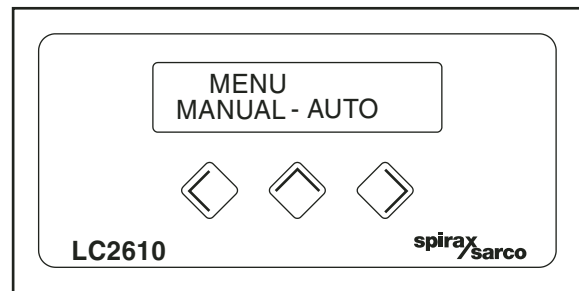

Limiting conditions

Maximum ambient temperature	131°F
Minimum ambient temperature	32°F
Protection rating (front panel only)	(NEMA 4) IP65
Note: Additional sealing is required between the LC2610 and the panel to maintain the IP65 rating.	
Protection of back of unit	None (open)
Maximum cable length (controller terminals 1 - 9)	330 ft

Technical data

Mains supply voltage	230 V setting 198 V - 264 Vac 115 V setting 99 V - 121 Vac
Maximum power consumption	6 VA
Internal fuse type	20 mm (0.8") cartridge
Internal fuse rating	100 mA anti-surge
External fuse maximum rating	3 amp quick blow (A fuse must be fitted to all phases of controller and relay supply)
Display:- type	20 character x 2 line alphanumeric - LED backlit
Character size	5 mm x 3 mm (approximately 0.2" x 0.1").
Note: Modulating control includes proportional plus a non-adjustable integral action.	

Materials

Case	Noryl (glass filled)
Front panel	Polyester

Approvals

UL	UL 508
United States Standard	Industrial Control Equipment E203559
cUL	C22.2 Number 14-M91
CSA Canadian Standard	Industrial Control Equipment E203559

LC 2610 Level Controller

Dimensions (approximate) in inches (mm)

Weight 1.6 lbs. (0.75 kg)

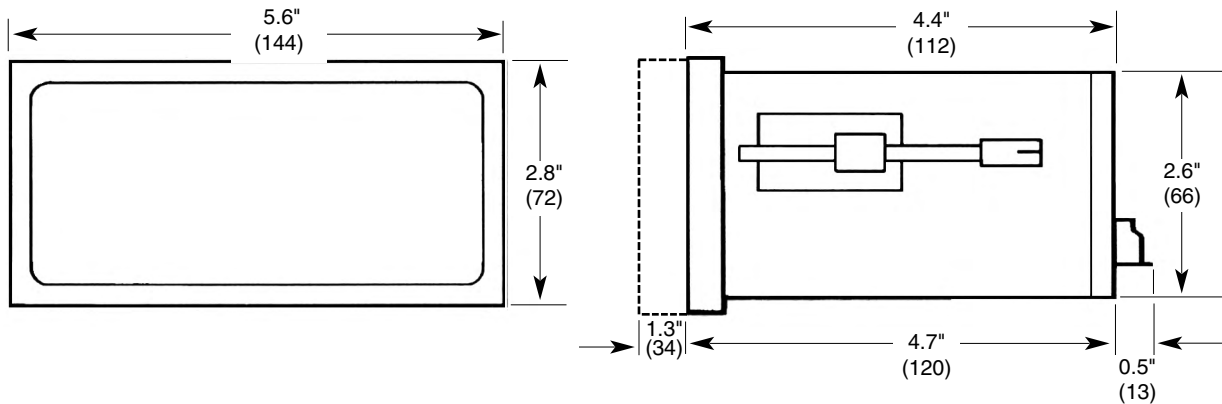

Safety information, installation and maintenance

This document does not contain sufficient information to install the product safely.

WARNING:

The controller operates at a potentially fatal voltage.

Do not attempt to install the LC2610 without first reading the Installation and Maintenance Instructions supplied with the unit. Copies may be obtained from Spirax Sarco.

Installation note:

The panel mounted LC2610 is installed in a 5.4" (137 mm) x 2.6" (67 mm) (approximate) cut-out and retained by side clips which tighten against the back of the panel. Additional sealing is required between the LC2610 and the panel to maintain the NEMA 4 (IP65) rating.

How to specify

Single unit level controller for on /off or modulating boiler or tank level control.

Specification:- 230 V / 115 V switch selectable supply voltage.

Two alarms, probe or 4 - 20 mA input, relay or 4 - 20 mA output, suitable for 2 or 3 element control duties.

Controller to be approved by Underwriters Laboratory as a Listed product.

How to order

Example: 1 of Spirax Sarco LC2610 level controller.