

# spirax/sarco®

## LP 10-4 Level Probe

- Single probe provides all the controls needed on a tank
- Suitable for use with steam boilers up to 464 psig (32 barg)
- For level control and simple alarm duties
- Stainless steel and PFA wetted parts

### Description

The Spirax Sarco LP10-4 level probe is used with Spirax Sarco LC1000 series level controllers to provide on / off level control and alarm functions in steam boilers, tanks or other vessels.

The four tip probe is particularly suitable where 3-lamp 'electric gauge glass' alarm/ level indicators are fitted. The probe body is grounded through its screwed connection and the boiler or tank normally forms the ground return path. The probe may also be used in concrete or plastic tanks by using one of the tips as a ground return, or by providing a separate ground rod or plate. The LP10-4 probe has four detachable level sensing tips which are cut to length on installation to give the required switching levels. Note: Tips are ordered separately, and are 39" long. Two sets of tips may be connected for a maximum probe length of 82". When a tip is immersed in conductive liquid it completes an electrical circuit to ground. When the level drops below the tip, the resistance to ground becomes high, indicating to the controller that the tip is out of the liquid.

### Limiting conditions

Nominal pressure rating	PN40
Maximum pressure	464 psig (32 bar)
Maximum temperature	462°F (239°C)
Maximum ambient temperature	158°F (70°C)
Minimum ambient temperature	-40°F ( -20°C)
Protection rating	NEMA 3R (IP54)
Maximum cable length (probe to controller)	100ft (30 m)
Maximum sensing depth	82" (2 095 mm)
Minimum sensing depth	3" (75 mm)

### Materials

No.	Part	Material
1	Probe body	Austenitic stainless steel Type 304L/ 1.4306
2	Probe tips	Austenitic stainless steel Type 316/ 316L
3	Tip insulation sleeving	PFA (Per Fluor Alkoxy)
4	Lower housing	PPS (Polyphenylene sulphide)
5	Upper housing	PPS (Polyphenylene sulphide)
6	Gland support pad	Thermoplastic elastomer
7	Cable gland	PA (Polyamide)
8	Tip steady	PEEK (Polyaryletherketone) Grade 450G

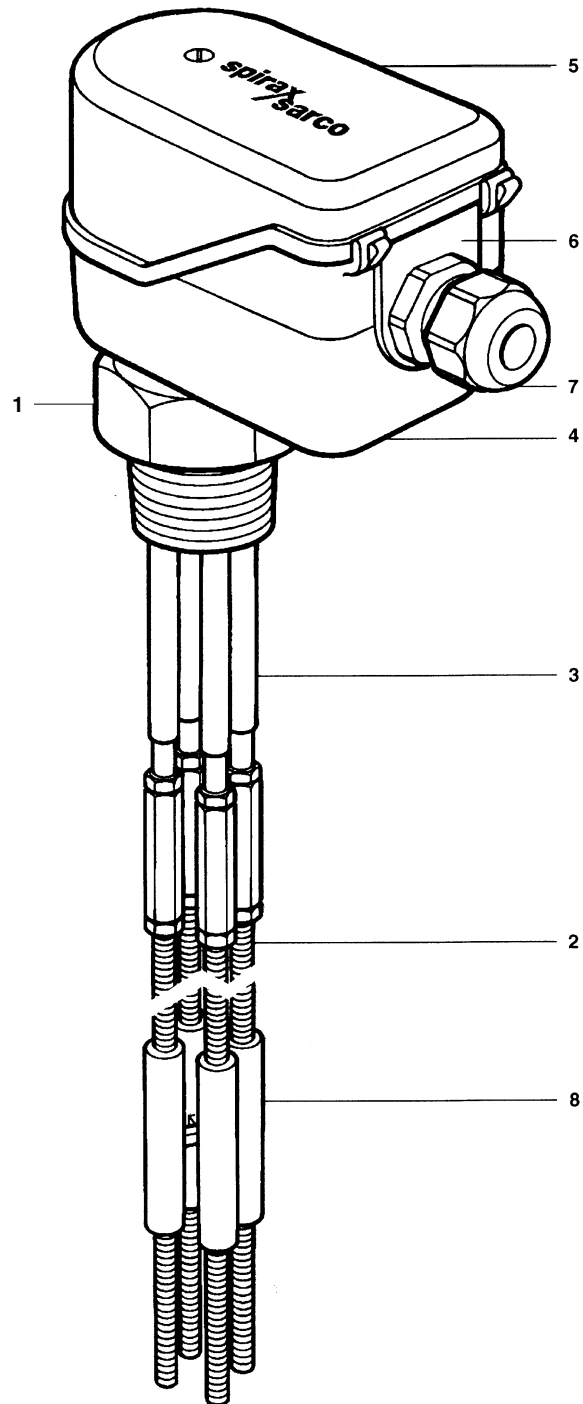

# LP 10-4 Level Probe

## Safety information

### WARNING

Your attention is drawn to Safety Information Leaflet IM-GCM-10, as well as to any National or Regional regulations.

This product is designed and constructed to withstand the forces encountered during normal use.

Use of the product for any purpose other than as a level probe could cause damage to the product and may cause injury or fatality to personnel.

This product contains materials including plastics which can give off toxic fumes if exposed to excessive heat. Additional environmental protection is needed for installation outdoors.

## Installation

This document does not contain sufficient information to install the product safely. See the Installation and Maintenance Instructions provided with every unit.

The LP10-4 is designed for installation in a 1" NPT threaded flange or cover. The probe tips are screwed to the probe body using the extension connectors and lock-nuts provided, then cut to length before installation to give the required switching levels. Tip steadies provide lateral support as well as insulation between the tips. For deep tanks/ boilers, the switching level may be extended to a maximum of 82" by fitting a second probe tip. A minimum 80 mm (3") nominal bore protection tube is recommended if installing the probe in a boiler, or in a tank which is subject to very turbulent conditions.

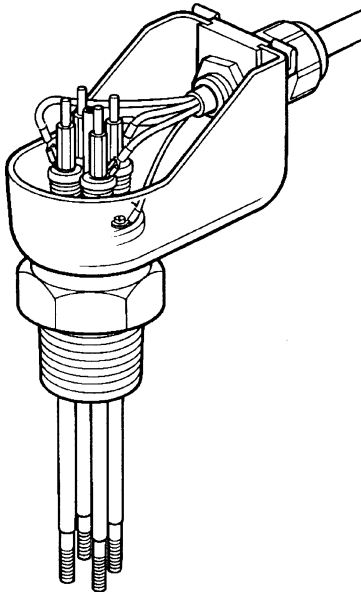

Dimensions / weight (approximate) in inches and lbs.

A	B	C	D	Weight
2.3	1	3	2	2.5

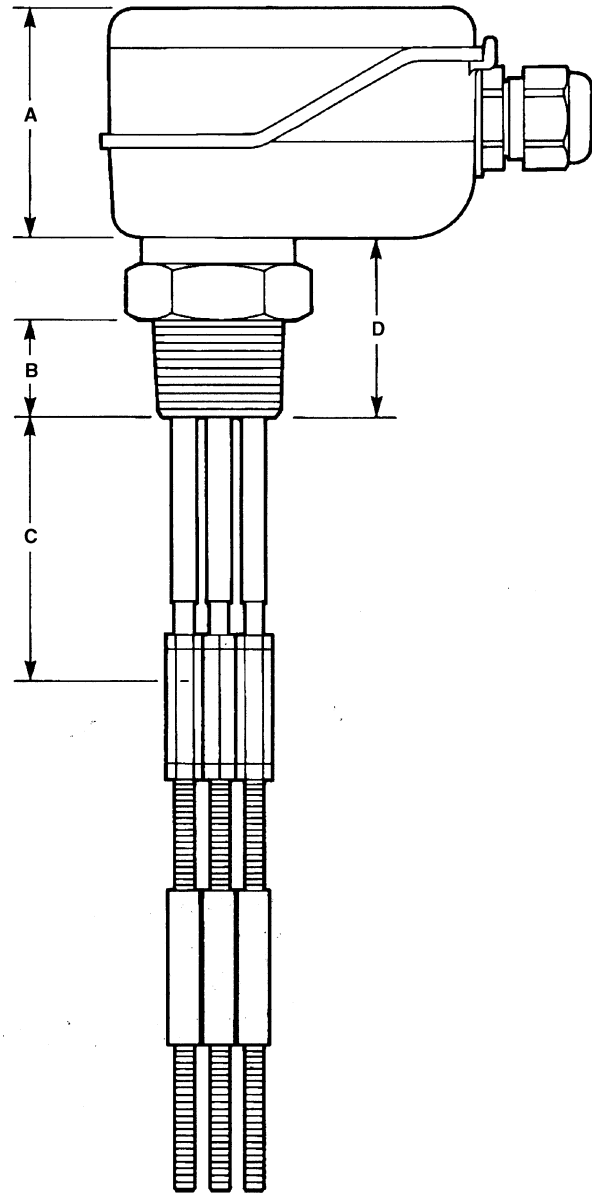

## Wiring

Wiring is straightforward on the LP10-4, as crimp connectors are used.

Extra connectors are available as a spares kit. Terminal posts are colour coded for easy identification.

The wiring loom may be disconnected and removed without disturbing the cable gland by lifting the gland carrier out of the lower housing.

## Maintenance

No special maintenance is required, though boiler water level controls do require periodic testing and inspection which is described in separate literature.

## How to specify

Conductivity probe with austenitic stainless steel body and probe tips, PFA tip insulation, suitable for steam boiler operation up to 464 psig (462°F)

## How to order

Example: 1 of Spirax Sarco LP10-4 probe with 39" tip assembly.

## Available spares

Crimp kit, comprising six flat crimp connectors and two ring crimps. Stock no. 4024480.