

LP 31 High Level Alarm Probe

- High integrity, self-monitoring high level alarm probe
- Suitable for pressures up to 464 psig, 462°F (32 barg, 239°C)
- Guards against the boiler flooding and water hammer in the steam mains
- Fail safe design
- Can also be used as a simple level probe

Description

The Spirax Sarco LP 31 is used with an LC3000 controller to provide a high integrity, self monitoring high level alarm for detection of high water levels in steam boilers and other vessels. The probe is normally installed direct in the boiler shell in a protection tube, but can be mounted in an external chamber if regulations permit. The LP 31 is supplied in three nominal tip lengths, and is cut to the exact length required prior to installation. In normal operation, the tip is above the water level, and has a high resistance to ground. If the water level rises to touch the probe tip, the resistance to ground drops, causing the alarm relays in the controller to be de-energized and the alarm to sound. The LP 31 is designed so that its tip and wiring connection integrity is monitored by the controller, causing an alarm signal in the event of a fault occurring. A DIN 43650 cable socket with 1/2" NPT conduit thread and four 18AWG wire are supplied with the unit.

Limiting Conditions

Maximum boiler pressure	464 psig (32 barg)
Maximum temperature	462°F (239°C)
Maximum ambient temperature	158°F (70°C)
Maximum probe cable length	165ft (50m)
Cable socket protection rating	IP65

Available Lengths

Tips are available in lengths of 19.7" (500 mm), 39.4" (1,000 mm), 59.1" (1,500 mm).

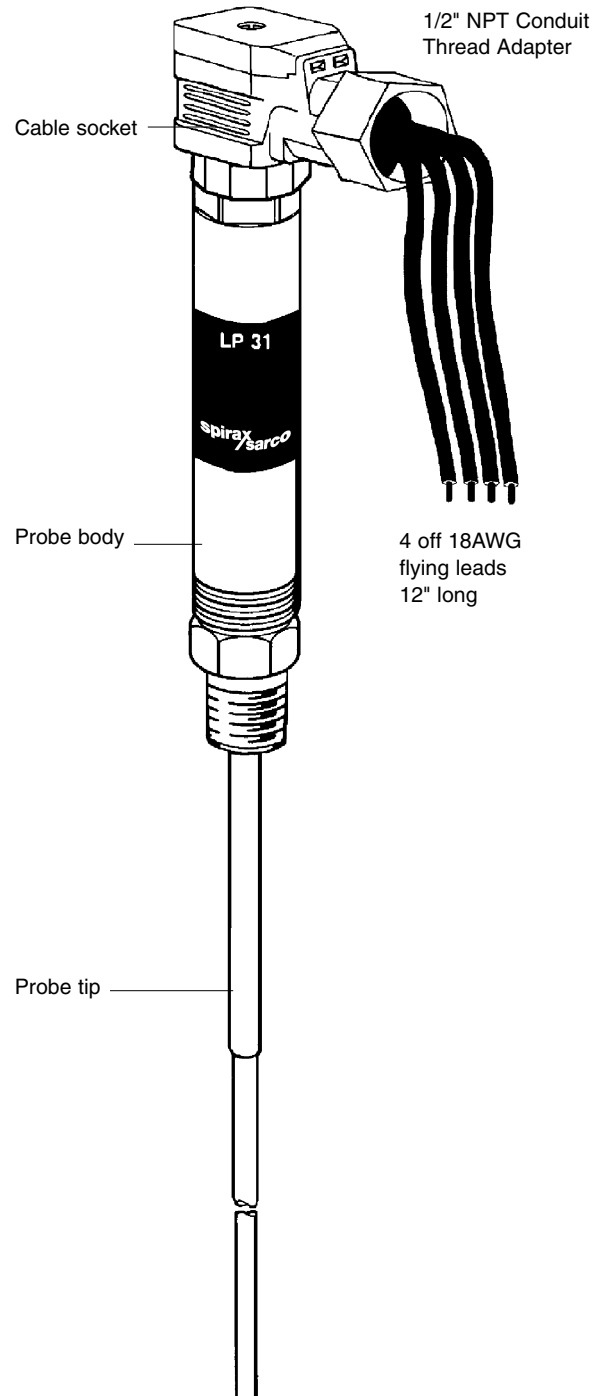

LP 31 High Level Alarm Probe

Dimensions (approximate) in inches and millimeters

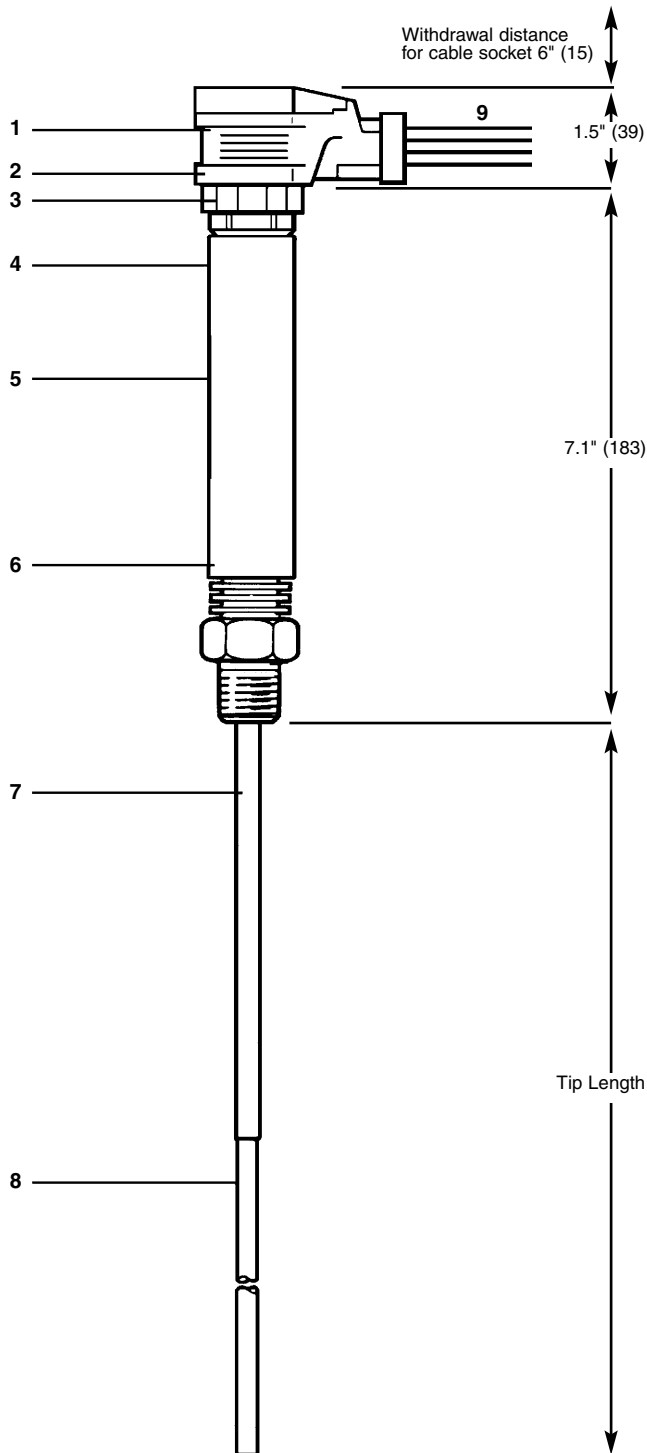

Materials

No.	Description	Material
1	Cable Socket	Polyamide, glass filled
2	Flat Gasket	Silicone Rubber
3	Probe Connector	Polyamide, glass filled
4	Cover Assembly	Austenitic Stainless Steel
5	Nameplate	Aluminum foil
6	Body	Austenitic Stainless Steel Type 316Ti W/S No. 1.4571
7	Probe Tip Sleeve	PTFE
8	Probe Tip	Austenitic Stainless Steel ASTM A276 316L
9	Flying leads	Copper conductor, PVC insulation 18AWG CSA TEW105°C, UL1015 105°C, 600V

Weight (approximate) including immediate packaging

19.7" (500mm) tip	1 lb (.51 kg)
39.4" (1000mm) tip	1.3 lb (.59 kg)
59.1" (1500mm) tip	1.5 lb (.67 kg)

Installation

The LP 31 tip is cut to length and de-burred prior to installation. The probe is installed in a 1/2" NPT thread using PTFE tape. Full installation and wiring instructions are provided with each unit.

How to Specify

Single tip, high integrity, self monitoring high alarm probe with all wetted parts in austenitic stainless steel/PTFE.

How to Order

Spirax Sarco UL LP31 (1/2" NPT) probe with 39.4" (1000mm) tip.

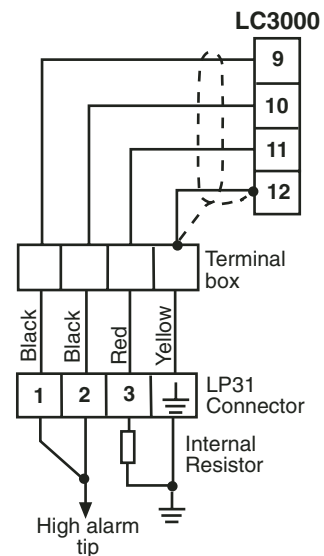

Approvals

UL	UL353
United States Standard	Limit Controls
	MH25452

ULC	C22.2 No. 24-93
Canadian Standard	MH25452