

# spirax/sarco®

## Stainless Steel Liquid Drain Trap FA-150

The **float-operated liquid drain trap** discharges continuously in direct response to variations in liquid flow rate, assuring thorough drainage of the system.

<b>Model</b> ⇄	FA-150
<b>PMO</b>	150 psig
<b>Sizes</b>	1/4"
<b>Connections</b>	NPT
<b>Construction</b>	Stainless Steel Body and Internals

### Typical Applications

Receiver and air line drainage, draining liquid from its vapor phase.

### Construction Materials

No.	Part	Material	
1	Body	Stainless Steel	AISI 304
2	Cover Screws	Plated Steel	ASTM A574
	Cover Nuts		ASTM A 563
3	Cover Gasket	Graphite	
4	Valve Seat	Stainless Steel	AISI 420F
5	'O' Rings	BUNA-N	
6	Float	Stainless Steel	AISI 304
7	Seat Bracket	Stainless Steel	AISI 301
8	Pivot Pin	Stainless Steel	AISI 303
9	Valve Head & Arm	Stainless Steel	AISI 300/440
10	Connection Stud	Stainless Steel	AISI 304
11	Connection Nut	Stainless Steel	AISI 303
12	Drain Plug	Stainless Steel	AISI 316

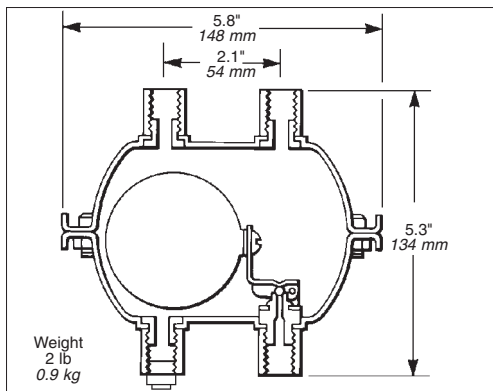
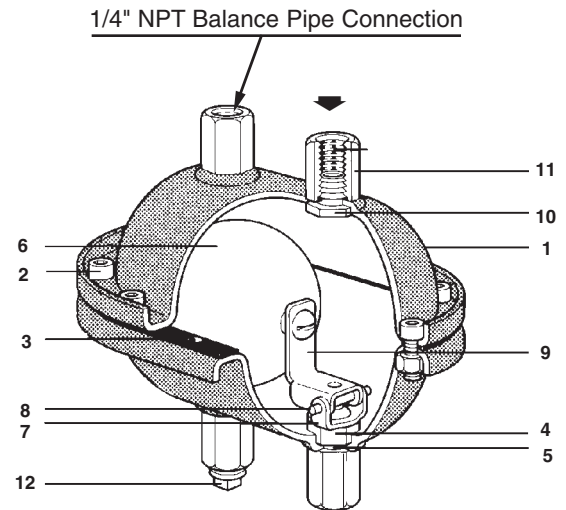

### Limiting Operating Conditions

#### Max. Operating Pressure (PMO)

Specific Gravity	psig	barg
1.0	150	10.3
.95	135	9.3
.90	119	8.2
.85	104	7.1
.80	89	6.1
.75	73	5.0
.70	58	4.0
.65	43	2.9
.60	25	1.7
.55	12	0.8

#### Max. Operating Temperature 250°F (121°C)

#### Pressure Shell Design Conditions

**PMA** 150 psig/0-250°F 10 barg/0-121°C  
Max. allowable pressure

**TMA** 250°F/0-150 psig 121°C/0-10 barg  
Max. allowable temperature

### Cold Water Capacity lb/h .10" (2.5mm) orifice diameter

		Differential pressure											
psi		1	2	5	10	20	30	50	65	75	100	125	150
bar		.07	.14	.34	.69	1.4	2.1	3.5	4.5	5.2	6.9	8.6	10.3
1/4"	FA-150	125	165	250	330	450	530	650	750	790	900	980	1025

For kg/h, multiply lb/h by .454

Local regulation may restrict the use of this product below the conditions quoted. Limiting conditions refer to standard connections only.  
In the interests of development and improvement of the product, we reserve the right to change the specification.

TI-7-307-US 03.06

# Stainless Steel Liquid Drain Trap

## FA-150

### Conversion Factors

for equivalent cold water capacity of light liquids

<b>Specific gravity</b>	.95-.99	.90-.94	.85-.89	.80-.84	.75-.79	.70-.74	.65-.69	.60-.64	.55-.59
<b>Conversion Factor</b>	1.03	1.06	1.09	1.12	1.16	1.20	1.24	1.29	1.35

### Draining Cold Water & Liquids of specific gravity 1.0

Obtain the required cold water capacity by multiplying the peak load by a safety factor of 1.5. Select the drain trap from the capacity table which satisfies the required cold water capacity and operates at the minimum pressure differential of the application.

### Draining Liquids of specific gravity 0.55 to 0.95

Determine the "Equivalent Cold Water Capacity" of the light liquid by multiplying its peak load (include a safety factor of 1.5) by the conversion factor given in the table above. If the maximum load is accurately known, the safety factor can be reduced or eliminated.

Refer next to Limiting Conditions table which gives the maximum operating pressure with various gravity liquids. For liquids between those listed, use the next lower specific gravity. Ensure that the maximum operating pressure is equal to, or greater than, the inlet pressure of the application.

### Sample Specification

The liquid drain trap shall be of the float type with screwed NPT connections. Body shall be stainless steel, and valve mechanism shall be stainless steel with hardened working surfaces designed to retain a water seal at all times. An NPT tapping shall be provided for a balance pipe. All internals are to be renewable and field serviceable.

### Installation

The trap must be fitted in a vertical pipe line so that the float mechanism is free to rise and fall in a vertical plane.

The high point of the cover is provided with a 1/4" NPT tapping for a balance pipe, which is essential for satisfactory operation of this unit. The balance pipe must be connected with a continuous rise between the tapping provided on the cover of the trap and the vessel being drained. The trap discharge should be piped to a safe place.

### Maintenance

This product can be maintained without disturbing the inlet piping connections. Complete isolation of the trap from both supply and return line is required before any servicing is performed.

The trap should be disassembled periodically for inspection and cleaning of the valve head and seat.

Worn or damaged parts should be replaced using a complete repair kit.

**Complete installation and maintenance instructions are given in IM-7-306-US which accompanies the product.**

Liquid drain traps can be used to drain most liquids from most gases. However, some applications, particularly those involving hazardous or unusual fluids, may be subject to regulation or may otherwise require special consideration.

Spirax Sarco will endeavor to provide whatever data is necessary to assist in product selection.

### Spare Parts

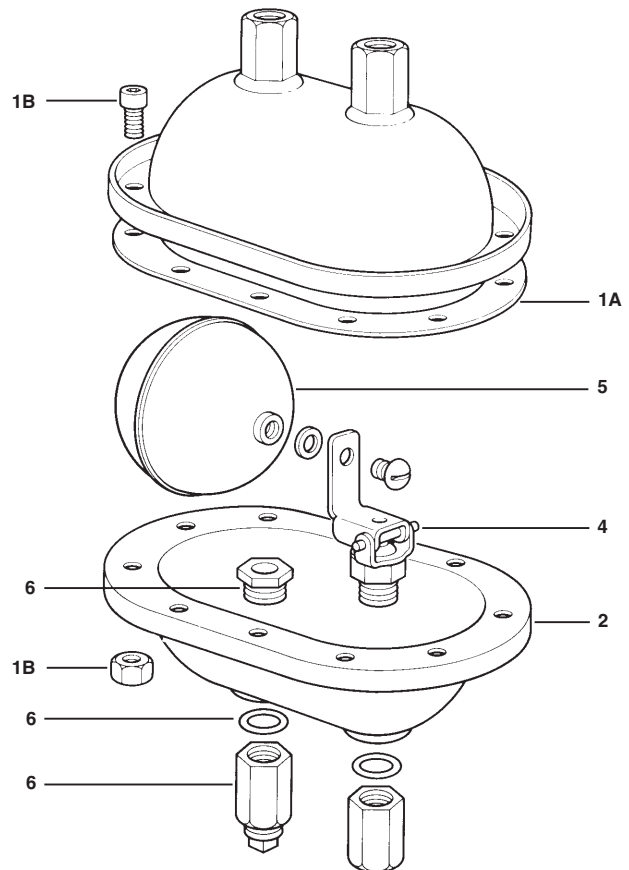

#### Gasket Kit (Set of 3 Cover & Seat Gaskets)

Complete valve mechanism assembly with 'O' ring	4
Float with Screw & Washer	5