

# spirax/sarco®

## Stainless Steel Liquid Drain Trap CA46S

The float-operated liquid drain trap discharges continuously in direct response to variations in liquid flow rate, assuring thorough drainage of the system.

Model	CA46S-4.5	CA46S-10	CA46S-14	CA46S-21
<b>Sizes</b>	1/2", 3/4", 1", 1-1/2", 2"			
<b>Connections</b>	ANSI 150 and 300 flanged			
<b>Construction</b>	316 Stainless Steel Body, Stainless Steel Internals			

**Note:** 1-1/2" and 2" valves are double-seated, and may not shut tight under no-load conditions. Normally, the liquid load will always be greater than the small residual leakage.

### Typical Applications

Process applications requiring an austenitic stainless steel liquid drain trap.

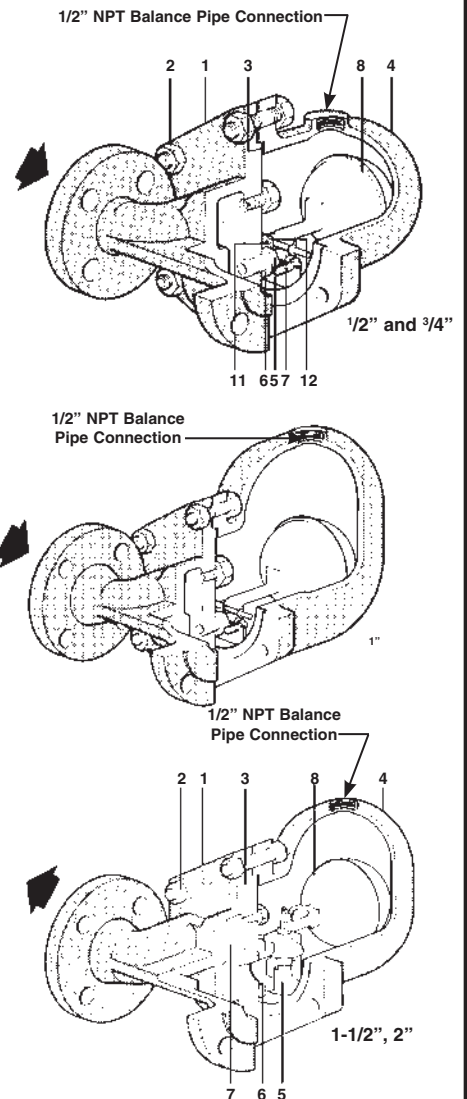

### Construction Materials

No.	Part	Material	
1	Body	Stainless Steel	AISI 316
2	Cover Bolts 1/2", 3/4", 1" 1-1/2", 2"	Stainless Steel	Class A2 Gr80
		M10 x 60 mm	
		M16 x 85 mm	
3	Cover Gasket	Stainless Steel	BS 1449 304 S16
4	Cover	Stainless Steel	AISI 316
5	Valve Seat 1/2", 3/4", 1"	Stainless Steel	BS 970 431 S29
	Main Valve Assembly w/ Erosion Deflector 1-1/2", 2"	Stainless Steel	BS 3146 Pt2 type ANC2 BS 970 416 S37
6	Valve Seat Gasket 1/2", 3/4", 1"	Stainless Steel	BS 1449 304 S11
	Main Valve Assembly Gasket 1-1/2", 2"	Stainless Steel	AISI 316
7	Pivot Frame Assembly	Stainless Steel	
	Set Screws 1/2", 3/4", 1"	M5 x 20 mm	BS 4183 18/8
	Main Valve Assembly Bolts 1-1/2"	Stainless Steel	
	Studs & Nuts 2"	M6 x 20 mm M8 x 20 mm	BS 970 304 S15 BS 6105 A4.80
8	Ball Float & Lever	Stainless Steel	BS 1449 304 S16
11	Support Frame	Stainless Steel	BS 1449 304 S16
12	Pivot Frame	Stainless Steel	BS 1449 304 S16

### Limiting Operating Conditions

**Max. Operating Pressure (PMO)** Up to 300 psig. The PMO depends on the model selected and the specific gravity of the liquid being drained. See TIS 7.318.

**Max. Operating Temperature** 750°F (400°C)

### Pressure Shell Design Conditions

<b>PMA</b> 49°C	580 psig/up to 121°F	40 barg/up to
Max. allowable pressure	398 psig/448°F	27 barg/231°C
	304 psig/752°F	21 barg/400°C
<b>TMA</b>	752°F/0-304 psig	400°C/0-21 barg
Max. allowable temperature		

Local regulation may restrict the use of this product below the conditions quoted. Limiting conditions refer to standard connections only. In the interests of development and improvement of the product, we reserve the right to change the specification.

TI-7-3022-US 11.09

# Stainless Steel Liquid Drain Trap CA46S

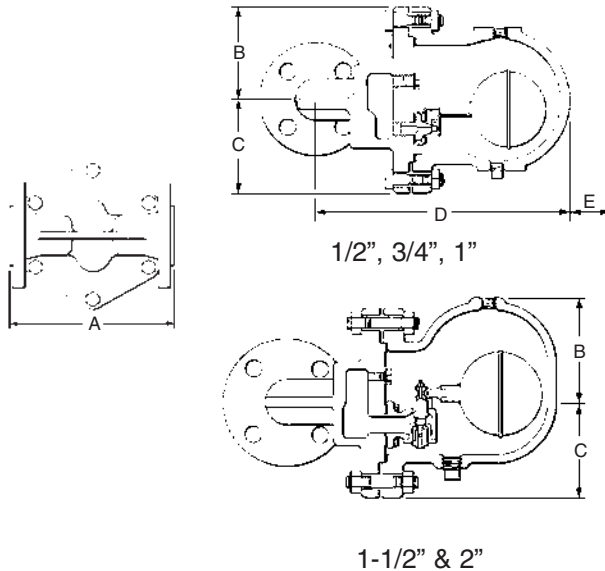

Size/DN	Dimensions (nominal) in inches and millimeters					Weight
	A	B	C	D	E	
1/2" 15	5.8 150	3.2 80	3.2 80	8.4 215	4.7 120	23.8 lb 10.8 kg
3/4" 20	5.8 150	3.2 80	3.2 80	8.8 225	4.7 120	23.8 lb 10.8 kg
1" 25	6.2 160	4.5 115	3.4 85	10.8 276	6.7 170	33 lb 15 kg
1-1/2" 40	9.0 230	4.8 130	4.5 115	12.7 326	7.9 200	72.8 lb 33 kg
2" 50	9.0 230	5.5 141	4.8 123	12.9 332	7.9 200	94.8 lb 43 kg

## Capacity

The discharge capacity depends on the differential pressure (inlet pressure minus outlet pressure) and the specific gravity of the liquid being drained. See TIS 7.318.

## Sample Specification

Steam traps shall be of the mechanical ball float type having stainless steel bodies, horizontal line connections, and all stainless steel internals. A 1/2" NPT tapping shall be provided for a balance pipe. All internals are to be renewable and field serviceable.

## Installation

The trap must be fitted in a horizontal pipe line with direction of flow as indicated and so that the float mechanism is free to rise and fall in a vertical plane. Full-flow isolating valves should be placed to permit servicing.

The high point of the body is provided with a 1/2" NPT tapping for a balance pipe, which is essential for satisfactory operation of this unit. The balance pipe must be connected with a continuous rise between the tapping provided on the body of the trap and the vessel being drained. The trap discharge should be piped to a safe place.

## Maintenance

This product can be maintained without disturbing the piping connections. Complete isolation of the trap from both supply and return line is required before any servicing is performed. The trap should be disassembled periodically for inspection and cleaning of the valve head and seat.

Worn or damaged parts should be replaced using a complete repair kit.

**Complete installation and maintenance instructions are given in IMI 7.306 which accompanies the product.**

Liquid drain traps can be used to drain most liquids from most gases. However, some applications, particularly those involving hazardous or unusual fluids, may be subject to regulation or may otherwise require special consideration. Spirax Sarco will endeavor to provide whatever data is necessary to assist in product selection.

## Spare Parts

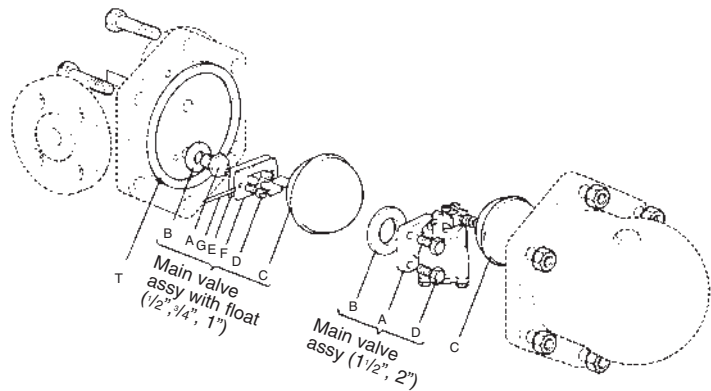

Main Valve Assembly w/ Float	A,B,C,D,E,F,G
Main Valve Assembly w/ Erosion Deflector (1-1/2", 2")	A,B,D
Ball Float (1-1/2", 2")	C
Three complete sets of Gaskets (Pkt of 3 sets) B,T	