

spirax sarco®

High Capacity Pressure Powered Pump™ 4" PPF-P

Spirax Sarco Pressure Powered Pump™ is a non-electric pump which transfers high temperature condensate or other liquids from a low point, low pressure or vacuum space to an area of higher pressure or elevation. This self-contained unit uses steam, compressed air or any other suitable pressurized gas as the pumping force. The PPF-P will handle liquids from 0.9 to 1.0 specific gravity.

Model ↔	PPF-P
PMO	150 psig
Sizes	4"
Connections	Inlet & outlet SW Flanges
Construction	150psig ASME code stamped with Stainless Steel Internals
Options	Up to 250 psig ASME body

Operating Characteristics

Pump discharge per cycle – 128 gal (484 l)
Average instantaneous discharge rate – 350 gpm (22 l/s)

Construction Materials

No.	Part	Material	
1	Cover	Steel	SA516 Gr 70
2	Cover Gasket	Graphite	
3	Pump Body – Shell	Carbon Steel	SA285 Gr 70
	– Heads	Carbon Steel	SA516 Gr 70
4	Mechanism Yoke	Cast Steel	
5	Mechanism Linkage	Stainless Steel	
6	Actuator Disc	Stainless Steel	
7	Float	Stainless Steel	
8	Spring	Inconel	
9	Check Valve	Stainless Steel	ASTM A351 CF3
10	Flex Hose	Stainless Steel	
11	Main Valve Casings	Cast Steel	ASTM A216 Gr WCB
12	Main Valve Head & Seats	Stainless Steel	
13	Main Valve Stems	Stainless Steel	
14	Main Valve Guides	Stainless Steel	
15	Main Valve Springs	Stainless Steel	
16	Diaphragm Plates	Brass	
17	Diaphragms	Phosphor Bronze	
18	Cap Gaskets	Graphite	
19	Pilot Valve Body & Caps	Stainless Steel	
20	Pilot Valve Trim	Stainless Steel	
21	Valve Trim Gaskets	Gln. Fn.	
22	Connector Gasket	Copper	ASTM B272
23	Packing	Teflon	

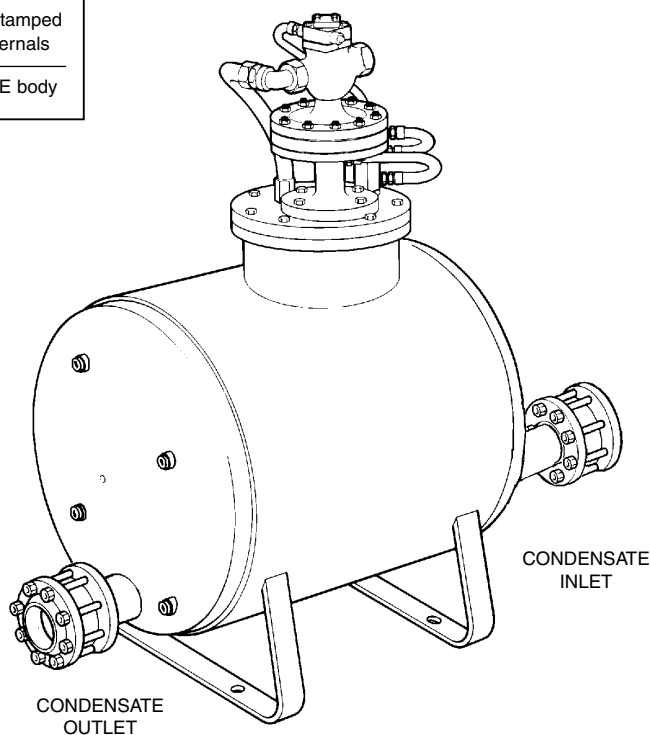

Accessories

Gauge glass with brass cocks; Reflex type gauge glass - (special order); Pump insulation cover; Cycle counter for measuring the amount of liquid pumped (A plugged 3/8" NPT boss is provided in the intermediate case on the main valve assembly for connecting the cycle counter).

Limiting Operating Conditions

Max. Operating Pressure (PMO) 150 psig (10.3 barg)
Minimum motive pressure required: 25 psig (1.7 barg)

Maximum backpressure is 80% of motive pressure for vented systems.
Specific Gravity of pumped liquid - 0.9 to 1.0

For closed loop systems, motive pressure must be 15 psi higher than backpressure. Vented systems minimum motive pressure 25 psi
Filling head recommended above pump is 24" (610 mm) (See TIS 5.202)

For increased service life, operate pump with motive pressure 15-20 psig - above pump back pressure.

Pressure Shell Design Condition

PMA 150 psig /0-650°F 10 barg/0-343°C
Max. allowable pressure

TMA 650°F/0-150 psig 343°C/0-10 barg
Max. allowable temperature

Capacities

For sizing and selection data, see TIS 5.202.

*Local regulation may restrict the use of this product below the conditions quoted. Limiting conditions refer to standard connections only.
In the interests of development and improvement of the product, we reserve the right to change the specification.*

TI-5-220-US 9.03

High Capacity Pressure Powered Pump™

4" PPF-P

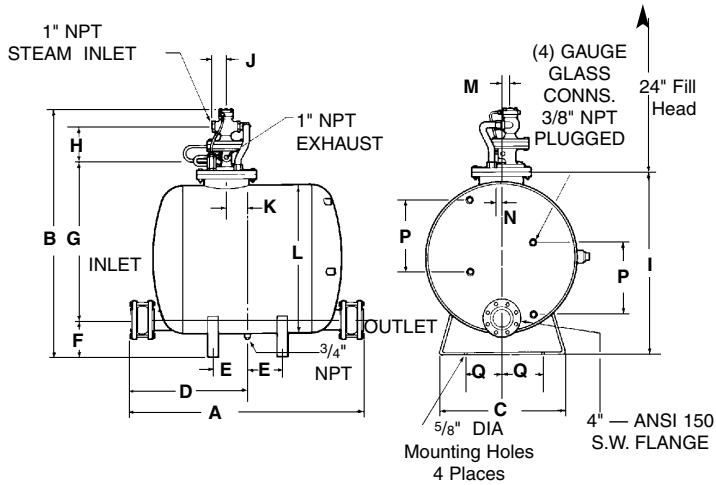

Sample Specification

The pump shall be a 4" Spirax Sarco pressure powered pump operated by steam from 25 to 150 psig. Body construction of welded steel, ASME Code Stamped for 150 psig service, with 4" socket weld ends. The pump shall contain a float operated snap-acting mechanism, which operates a pilot valve and two-way steam/gas valve, and requires no electrical energy for operation.

The pump mechanism and valves shall be steel construction with stainless steel trim and hardened stainless steel mechanism bearing components. When required, shall be equipped with a cycle counter to monitor the volume of liquids being pumped, and sight glass to track operation.

Dimensions (nominal) in inches and millimeters									
A	B	C	D	E	F	G	H	I	
56	60	30.5	27.6	8.3	8.75	40.1	7.1	44.3	
1422	1524	775	701	211	222	1019	180	1125	
J	K	L	M	N	P	Q	Weight		
3.0	3.4	36.2	2.5	0.7	17.5	12	1132 lb		
76	86	919	64	18	445	305	513 kg		

Maintenance

Complete installation and maintenance instructions are given in IMI 5.220, a copy of which is supplied with each pump. Available spare parts are shown on TIS 5.221.

Spare Parts

See TIS 5.221.

Installation

Full details are given in IMI 5.220, which accompanies the product.

