

spirax sarco®

Vented Pressure Powered Pump Packages PPEC / PTC / PTF

The modular pumping system consists of the standard PPEC / PTC / PTF Pressure Powered Pumps, pre-piped with the necessary auxiliary components and integral receiver mounted on a skid base. The unit offers versatility of providing a base mounted module and pump with added modular options for a comprehensive fully engineered modular package ensuring a technically correct and complete hook up.

Standard Pump Packages

Model		PPEC Simplex Pump Package	PPEC Duplex Pump Package
Limiting Conditions	PMA:	See TI-5-218-US	See TI-5-218-US
	TMA:	See TI-5-218-US	See TI-5-218-US
	Receiver Tank:	Rated for atmospheric pressure only. 650°F / 0 psig Sized for flash steam rates of up to 375 lb/hr.	Rated for atmospheric pressure only. 650°F / 0 psig Sized for flash steam rates of up to 375 lb/hr for 1" PPEC and 1150 lb/hr for 1 1/2" PPEC.
Sizes	Pump:	1" x 1" & 1 1/2" x 1 1/2"	1" x 1" & 1 1/2" x 1 1/2"
	Receiver:	8 Gallons	1" PPEC 8 Gallons, 1 1/2" PPEC 26 Gallons
Capacity		See TI-5-202	See TI-5-202
Construction		Fabricated steel receiver tank and frame. Ductile Iron pump body Stainless steel pump internals Stainless steel check valves	Fabricated steel receiver tank and frame. Ductile Iron pump body Stainless steel pump internals Stainless steel check valves
Model		PTC Simplex Pump Package	PTC Duplex Pump Package
Limiting Conditions	PMA:	See TI-5-010-US	See TI-5-010-US
	TMA:	See TI-5-010-US	See TI-5-010-US
	Receiver Tank:	Rated for atmospheric pressure only. 650°F / 0 psig Sized for flash steam rates of up to 1150 lb/hr.	Rated for atmospheric pressure only. 650°F / 0 psig Sized for flash steam rates of up to 2000 lb/hr.
Sizes	Pump:	2" x 2" & 3" x 2"	2" x 2" & 3" x 2"
	Receiver:	26 Gallons	57 Gallons
Capacity		See TI-5-202	See TI-5-202
Construction		Fabricated steel receiver tank and frame. Ductile Iron pump body Stainless steel pump internals Stainless steel check valves	Fabricated steel receiver tank and frame. Ductile Iron pump body Stainless steel pump internals Stainless steel check valves
Model		PTF Simplex Pump Package	PTF Duplex Pump Package
Limiting Conditions	PMA:	See TI-5-010-US	See TI-5-010-US
	TMA:	See TI-5-010-US	See TI-5-010-US
	Receiver Tank:	Rated for atmospheric pressure only. 650°F / 0 psig Sized for flash steam rates of up to 1475 lb/hr.	Rated for atmospheric pressure only. 650°F / 0 psig Sized for flash steam rates of up to 2500 lb/hr.
Sizes	Pump:	2" x 2" & 3" x 2"	2" x 2" & 3" x 2"
	Receiver:	31 Gallons	65 Gallons
Capacity		See TI-5-202	See TI-5-202
Construction		Fabricated steel receiver tank and frame. Fabricated pump body, ASME coded. Stainless steel pump internals Stainless steel check valves	Fabricated steel receiver tank and frame. Fabricated pump body, ASME coded. Stainless steel pump internals Stainless steel check valves

Standard Pump Package Options

- Pump motive inlet (fully trapped) and exhaust piping.
- Overflow pipe.
- Pump drain
- Receiver only
- ASME coded receiver (150 psig @ 450°F)
- Pump and receiver gauge glass
- Inline strainer
- Pressure gauges
- Receiver with modified connections.
- Pump isolation valve on outlet.

*Local regulation may restrict the use of this product below the conditions quoted. Limiting conditions refer to standard connections only.
In the interests of development and improvement of the product, we reserve the right to change the specification.*

TI-5-203-US 07.10

Vented Pressure Powered Pump Packages PPEC / PTC / PTF

PPEC Simplex Pump Package

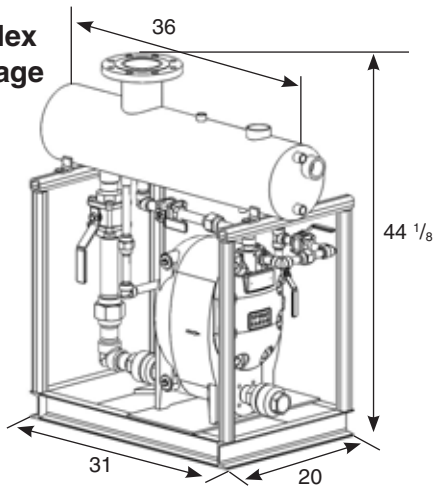

1-1/2" PPEC Duplex Pump Package

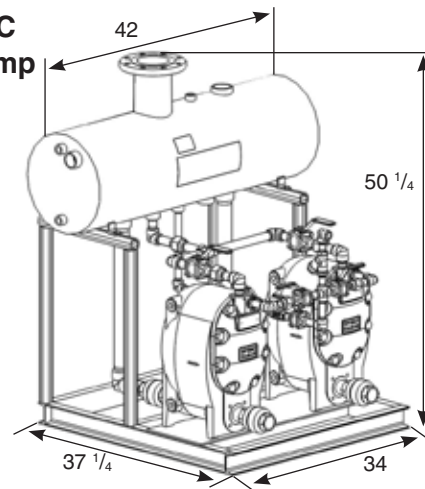

PTC Simplex Pump Package

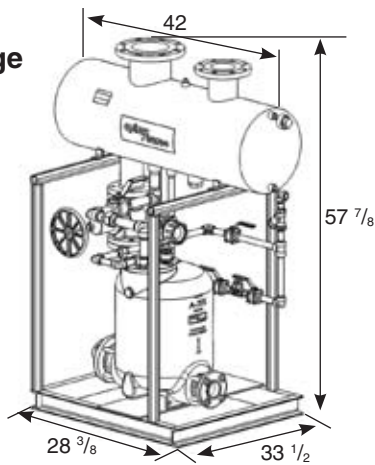

PTC Duplex Pump Package

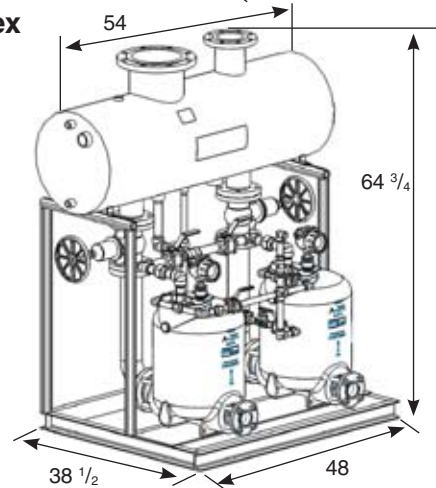

PTF Simplex Pump Package

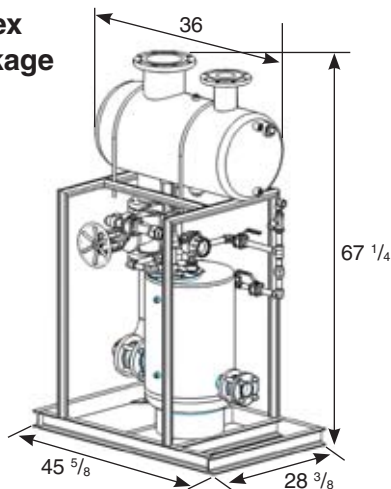

PTF Duplex Pump Package

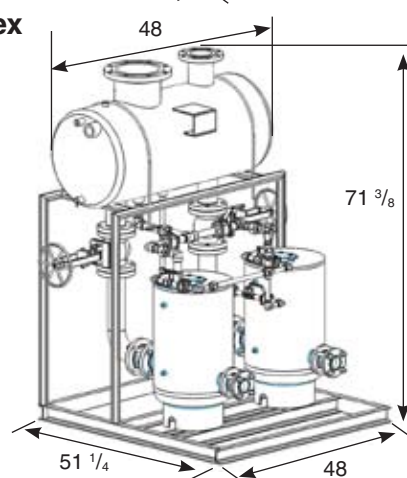

Note: All packages shown as base package with steam inlet and exhaust pipe modular option included. All sizes are approximate.

Sample Specification

The Pump Package Unit should be a Spirax Sarco Pressure Powered Pump Unit operated by steam, compressed air or other pressurized gas to 200 psig, which does not require any electrical energy and is safe for use in explosive atmospheres. The pump shall be a Spirax Sarco Pressure Powered Pump and supplied complete with vented receiver as a pre-piped packaged unit ready for commissioning. The pre-piped package should include the Pressure Powered Pump with stainless steel check valves and include motive inlet and exhaust piping, trapped for efficient pump operation. The pump shall have a float operated snap-acting mechanism and hardened stainless steel mechanism bearing components with no external seals or packing. For ease of maintenance, safety and system diagnosis an overflow, inline strainer, pump cycle counter, pressure gauges, pump drain and isolation valves should be included to ensuring a technically correct hook up.

TI-5-203-US 07.10