

spirax/sarco®

Balanced Pressure Thermostatic Air Vent T202

The T202 air vent is designed for use on steam systems to remove air and other non-condensable gases, which may impair heat transfer during start-up and normal operation.

Model ⇄	T202
PMO	125 psig
Sizes	3/8" x 1/4"
Connections	NPT
Construction	Brass Body with Stainless Steel Internals

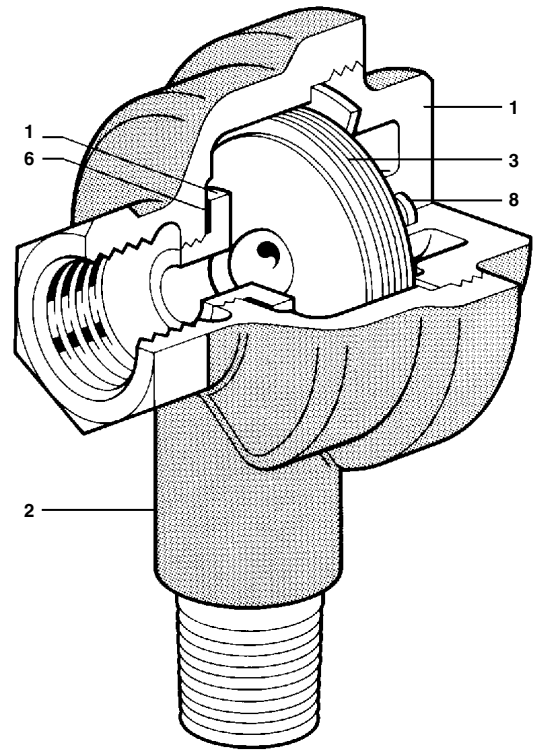

LIMITING OPERATING CONDITIONS

Max. Operating Pressure (PMO) 125 psig (8.6 barg)

Max. Operating Temperature Saturated Steam Temperature

PRESSURE SHELL DESIGN CONDITIONS

PMA 125 psig/up to 353°F 9 barg/up to 178°C
Max. allowable pressure

TMA 353°F/0-125 psig 178°C/0-9 barg
Max. allowable temperature

CONSTRUCTION MATERIALS

No.	Part	Material	
1	Cap	Brass	ASTM B124 Class 2
2	Body	Brass	ASTM B62
3	Thermostatic Bellows	Stainless Steel	300 & 400 Series SS
5	Seat	Stainless Steel	AISI 303
6	Seat Gasket	Brass	ASTM B36 Alloy 8
8	Spring	Stainless Steel	AISI 304

TYPICAL APPLICATIONS

For installation at end of all steam mains and headers, on all steam equipment such as air coils, heat exchangers, autoclaves, sterilizers, platen presses, rotating cylinders, jacketed kettles, laundry equipment and reboilers.

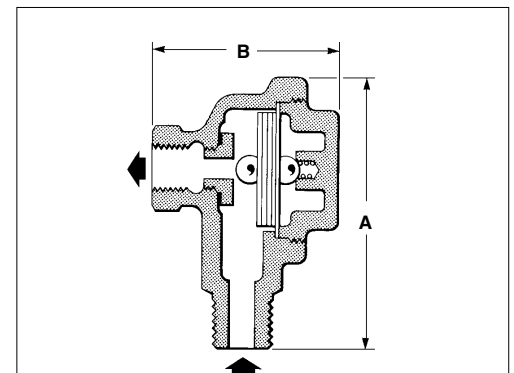

DIMENSIONS (NOMINAL) IN INCHES AND MILLIMETERS

Size	Outlet	A	B	Weight
3/8"	1/4"	2.9	2.1	1.0 lb
		75	54	.045 kg

Seat orifice – 1/4" diameter

Local regulation may restrict the use of this product below the conditions quoted. Limiting conditions refer to standard connections only.
In the interests of development and improvement of the product, we reserve the right to change the specification.

TI-4-104-US 03.94

Balanced Pressure Thermostatic Air Vent T202

SAMPLE SPECIFICATION

Air Vents shall be installed at the end of all steam mains and headers, and on large equipment steam spaces to facilitate start-up and heat transfer. They shall be self-adjusting balanced pressure thermostatic type with precision welded multiple plate stainless steel bellows. Head shall be hardened and both head and seat shall be stainless steel. Body and cap shall be brass and internals shall be renewable.

INSTALLATION

The air vent should be positioned at a high point of the piping system or equipment, or where the air collects. The discharge can be hot and wet; the outlet should therefore be piped to a safe place. An isolation valve should be fitted upstream of the air vent.

MAINTENANCE

This product can be maintained without disturbing the inlet piping connections. Complete isolation is required before any servicing is performed.

The air vent should be disassembled periodically for inspection and cleaning of the valve head and seat.

Worn or damaged parts should be replaced using a complete element set.

Complete installation and maintenance instructions are given in the IMI sheet, which accompanies the product.

AIR CAPACITY (discharge to atmosphere)

SCFM cubic feet per minute at standard conditions of 14.7 psig at 60°F. For dm³/s multiply by .4719.

		Inlet Pressure					
psi		5	10	25	50	100	125
bar		.34	.68	1.7	3.4	6.9	8.6
SCFM		8	13	25	40	70	80

SPARE PARTS

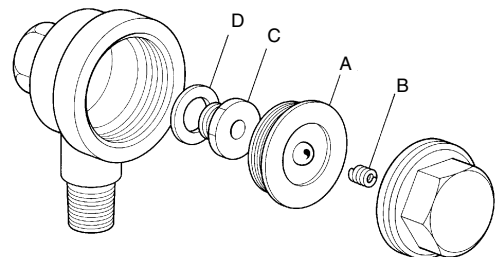

Element Set

A, B, C, D