

spirax sarco

Stainless Steel Sanitary Pressure Regulator SRV6

The SRV6 is an angle pattern, sanitary pressure regulator with polished 316/316L stainless steel construction for use on steam, process liquids and gases.

Model	SRV6
Sizes	1", 1 1/2", 2"
Connections	Tri-Clamp®* compatible
Construction	All 316/316L Stainless Steel Wetted Parts

* A registered trademark of Tri-Clover, Inc.

Construction Materials

No.	Part	Material	
1	Adjusting screw	Stainless Steel (PTFE coated)	AISI 303
2	Lock nut	Stainless Steel	AISI 304
3	Spring chamber	Stainless Steel	AISI 316L
4	Spring pusher	Stainless Steel	AISI 304
5	Spring	Stainless Steel	
6	Diaphragm nut	Stainless Steel	AISI 304
7	Spring washer	Stainless Steel	
8	Spacer ring	Stainless Steel	AISI 304
9	Retainer	Stainless Steel	AISI 304
10	Upper disc	Stainless Steel	AISI 304
11	V-band clamp	Stainless Steel	AISI 300 Series
12	Lower disc	Stainless Steel	AISI 316
13	Main valve	Stainless Steel	AISI 316
14	Body	Stainless Steel	AISI 316L
15	Diaphragm	Viton/PTFE (FDA approved)	

Surface Finish

All wetted parts mechanically polished to 20 microinch Ra then electropolished. All external parts electropolished.

Pressure Ranges

Downstream Control Range: 7-75 psi 0.5– 5.2 bar

Shutoff

ANSI Class III

Note: The SRV6 should **not** be used for line isolation. If line isolation is required, a suitable shut-off valve should be installed upstream of the SRV6.

Limiting Operating Conditions

Max. Operating Pressure (PMO) 116 psig 8.0 barg

Max. Operating Temperature 347°F 175°C

Pressure Shell Design Conditions

PMA 232 psig 15 barg
Max. allowable pressure

TMA 347°F 175°C
Max. allowable temperature

Typical Applications

Clean steam, gas, and liquid supplies to bioreactors, centrifuges, freeze dryers (lyophilizers), sterilizers, autoclaves, process tanks, production suites, humidifiers, and culinary equipment.

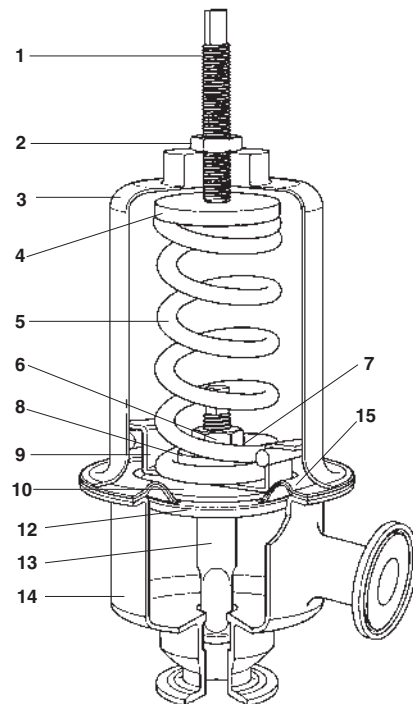
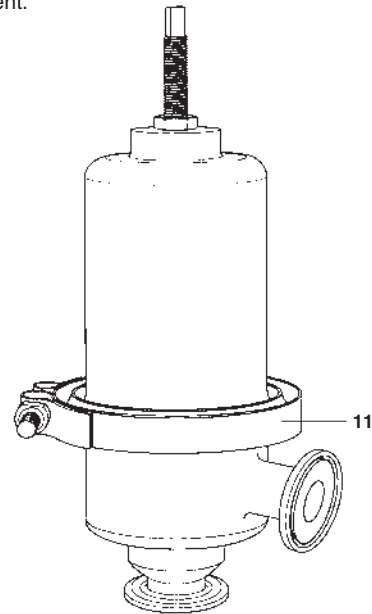

Local regulation may restrict the use of this product below the conditions quoted. Limiting conditions refer to standard connections only.
In the interests of development and improvement of the product, we reserve the right to change the specification.

TI-3-111-US 05.11

Stainless Steel Sanitary Pressure Regulator SRV6

Valve Selection:

Step 1

For Steam:

Establish whether the flow is critical or non-critical, and calculate the required C_v using one of the following formula:

$$\text{Critical } \Delta P \quad C_v = \frac{Q}{1.6 \times P_1} \\ P_2 < 1/2 P_1$$

$$\text{Noncritical } \Delta P \quad C_v = \frac{Q}{3.2 \times \sqrt{(P_1 - P_2) \times P_2}} \\ P_2 > 1/2 P_1$$

All pressures in psi absolute

For Liquids:

Calculate the required C_v using the following formula:

$$C_v = W \sqrt{\frac{S.G.}{\Delta P}}$$

Q = Steam load lb/h
P1 = Primary pressure (psia)
P2 = Secondary pressure (psia)
W = Liquid flow rate (GPM)
SG = Specific gravity of liquid
 ΔP = Pressure differential

STEP 2

For highest control accuracy, especially on widely fluctuating loads, select the valve size with the closest C_v at 20% droop to the required value.

For steady load applications, or where high accuracy of control is not required, the maximum C_v figure can be used for selection.

C_v Values			
Valve size	1"	1-1/2"	2"
Average C_v at 20% droop	2.5	3.0	4.2
Maximum C_v	5.5	13.5	27

Dimensions

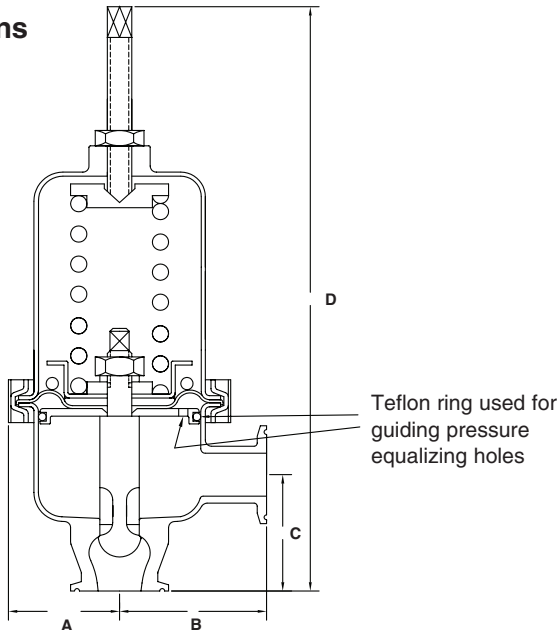

Dimensions (nominal) in inches and millimeters

Size	A	B	C	D	Weight lb(kg)
1"	2.3	3.0	2.4	12	6.5
	58	77	60	305	3.0
1-1/2"	2.3	3.0	3.5	13.3	7.2
	58	77	90	340	3.3
2"	2.3	3.0	4.3	14.8	8.9
	58	77	110	355	4.0

Installation

The SRV6 should be installed with the inlet vertical and the spring chamber upward. Full installation instructions accompany each valve.

Maintenance

Complete isolation of the valve is required before any servicing is performed. **Full installation & maintenance instructions are given in IMI 3.111 which accompanies the product.**

Spare Parts

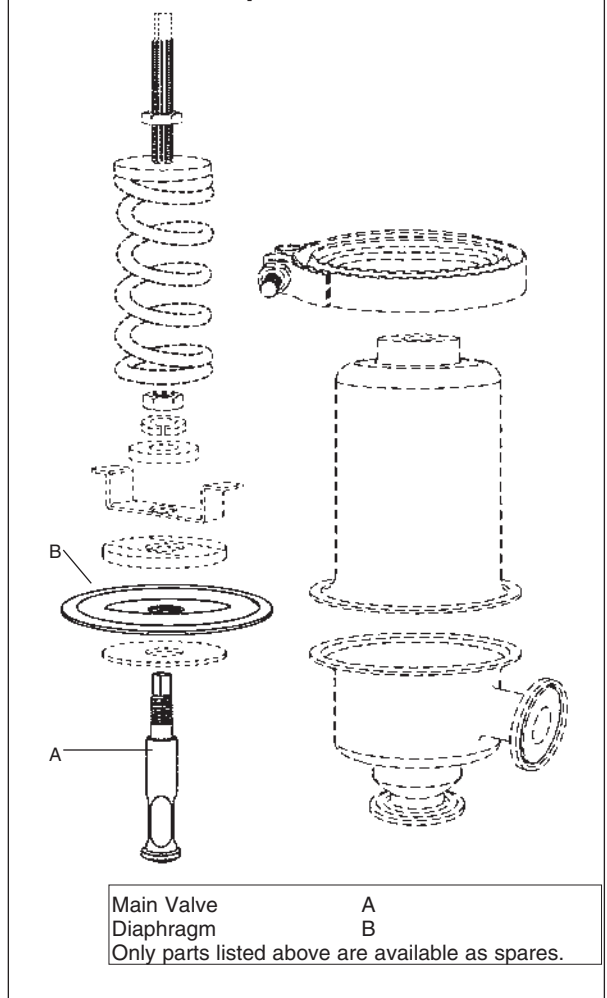

Sample Specification

Stainless steel sanitary pressure regulator shall be diaphragm actuated with integral valve guide and have all wetted parts in AISI 316/316L mechanically polished to 20 microinch Ra then electropolished. All parts AISI 300 series with electropolished external surfaces. Angle pattern design shall be fully self-draining when installed with inlet vertical. Valve travel stops shall prevent over extension of diaphragm, and diaphragm shall include an integral valve stem seal, complete with restraint. Spirax Sarco SRV6 sanitary pressure regulator

TI-3-111-US 05.11