

spirax sarco®

Combination Pressure/Temperature Regulator w/ Electric Override 6" 25PTE

The 25PTE has all of the features of the 25PT pressure/temperature regulator, with the addition of an electric pilot which permits an electrical signal to override the temperature and pressure pilots. The valve meets Class IV shut-off specifications but is not suitable for dead-end service. Standard capillary tubing lengths are 8ft and 15ft.

Model	25PTE	
Sizes	6"	
Connections	ANSI 125, 250	ANSI 150, 300
Construction	Cast Iron	Cast Steel
Options	Reduce Orifice Designated by "S" Non-standard capillary tubing length in 5 ft intervals to a maximum of 50ft. (See TI-1-1123-US)	
Electric Pilot Specifications	Enclosure: NEMA 4 & 7 (C&D) 115v (230v)/60Hz Inrush: 45 VA Normally closed 200 psig Max. operating pressure	
Electric Pilot Options	At pressures below 125 psig, use the following electric pilot: Enclosure: NEMA 4 & 7 (C&D) 115v (230v)/60Hz Inrush: 45 VA Normally closed 140 psig Max Operating Pressure	

Typical Applications

Pressure/Temperature control applications where the regulator must also respond to an electrical program timer, safety or limit switch, or remote manual switch.

Sample Specification

Pressure/Temperature Regulators shall be of the pilot-actuated, diaphragm-operated type with separate pressure and temperature pilots. The main valve shall be single-seated, with hardened stainless steel trim; the regulator body shall be cast iron. The pilots shall be removable without disturbing the control connections. The temperature setting shall be adjustable without the use of tools, and the set point shall be indicated on a calibrated dial. The thermostatic system shall be solid fill, and shall incorporate overheat protection.

Capacities

The regulator is sized according to the temperature control requirements. For selection and sizing, see TI-1-1124-US and TI-3-030-US.

Limiting Operating Conditions

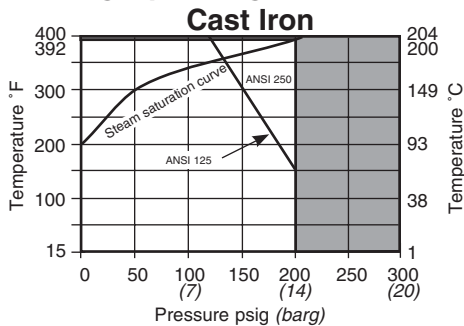

The product should not be used in shaded area.

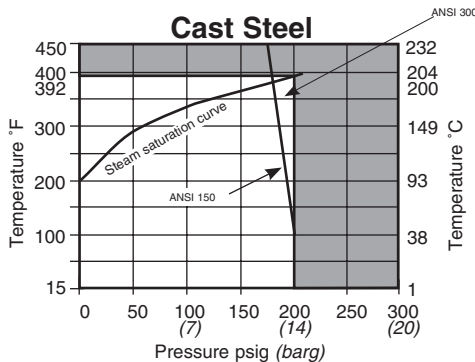

The product should not be used in shaded area.

C_v Values

Size	6"	6" "S"
C _v value	260	185

*The temperature of the sensing bulb must not exceed 350°F (177°C)

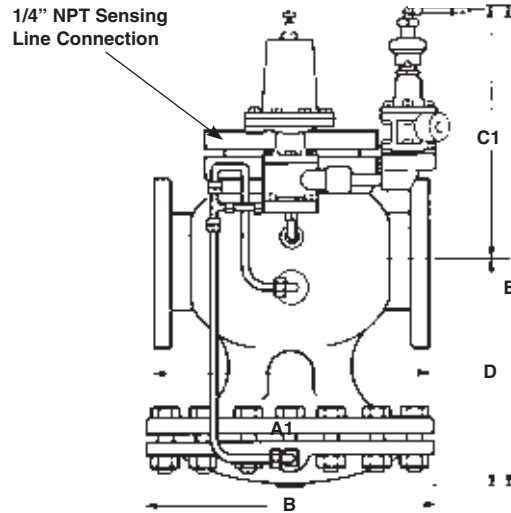

Dimensions (nominal) in inches and millimeters

Size	Ansi 125/150		Ansi 250/300		D	E	F	Weight
	A1	A1	B	C1				
6"	18.1	19.0	19.75	13.0	16.7	29.7	5.0	560 lb
	460	483	502	330	424	754	127	254 kg

Standard Temperature Ranges

30°F to 90°F	0°C to 32°C		
60°F to 120°F	15°C to 50°C	160°F to 220°F	70°C to 105°C
100°F to 160°F	40°C to 70°C	200°F to 260°F	95°C to 125°C
120°F to 180°F	50°C to 80°C	260°F to 320°F	125°C to 160°C

Downstream Pressure Ranges

For the following downstream pressures, 3 color-coded pilot valve springs are available:

Yellow: 3 to 30 psi **Blue:** 20 to 100 psi **Red:** 80 to 190 psi

Local regulation may restrict the use of this product below the conditions quoted. Limiting conditions refer to standard connections only.

In the interests of development and improvement of the product, we reserve the right to change the specification.

TI-3-0181-US 06.10

Combination Pressure/Temperature Regulator w/ Electric Override 6" 25PTE

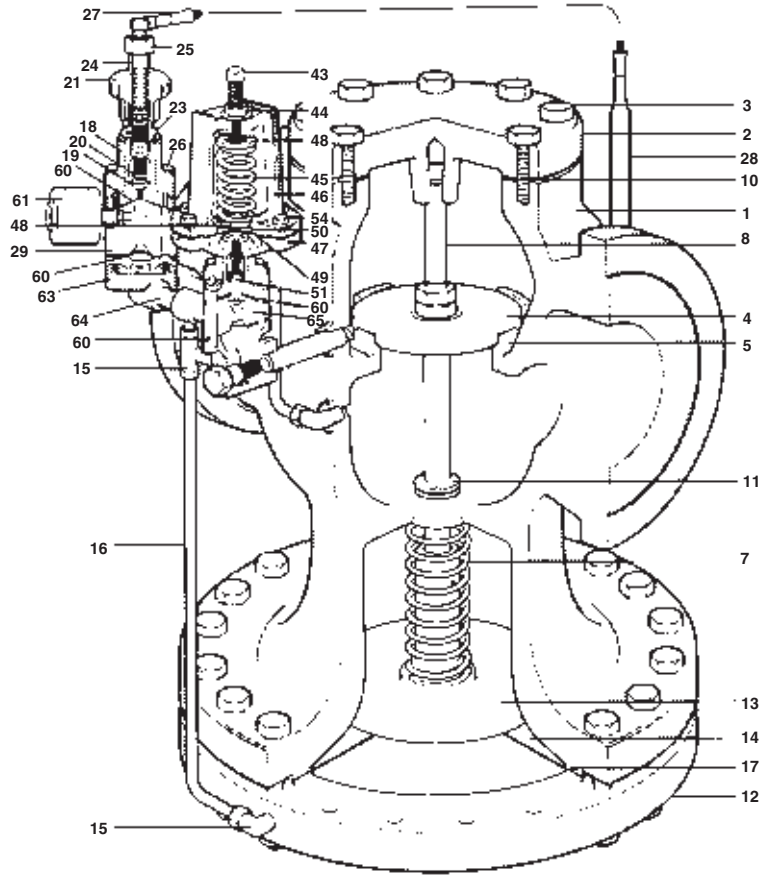

Construction Materials

No.	Part	Material	
1	Valve Body	Cast Iron	ASTM A 126 CL B
		Cast Steel	ASTM A 216 WC B
2	Cover	Cast Iron	ASTM A 126 CL B
		Cast Steel	ASTM A 216 WC B
3	Cover Bolts	Steel	AISI 1038
4	Main Valve Head	Stainless Steel	ASTM A 743 CA 40
5	Main Valve Seat	Stainless Steel	ASTM A 743 CA 40
7	Valve Return Spring	Stainless Steel	AISI 302
8	Valve Stem	Stainless Steel	AISI 304
10	Cover Gasket	Graphite	BS 2815 A
11	Stem Bushing	Brass	ASTM B16
12	Lower Diaphragm Case	Cast Iron	ASTM A 126 CL B
		Cast Steel	ASTM A 216 WC B
13	Diaphragm Plate	Stainless Steel	ASTM A 743 CA 40
14	Main Diaphragm (2 ply)	Stainless Steel	ASTM A240
15	Tube & Orifice	Brass	ASTM B16
16	Tubing Assembly	Copper	ASTM B280 (122)
17	Diaphragm Gasket (2)	Graphite	BS 2815 A
18	Pilot Valve Body	Cast Iron	ASTM A 126 CL B
		Cast Steel	ASTM A 216 WC B
19	Pilot Valve Seat	Stainless Steel	AISI 303
20	Pilot Valve Head	Stainless Steel	AISI 440A
21	Adjustment Knob	Phenolic	ASTM D 700 Ty2
23	Extension Nut	Brass	ASTM B16
24	Case Tube	Brass	ASTM B 135 (330)
25	Retaining Nut	Brass	ASTM B 16
26	Pilot Mounting Screws	Steel	ASTM A 449
27	Capillary Tube	Varies with style selected	
28	Bulb	Varies with style selected	
29	Electric Pilot Adaptor	Cast Bronze	ASTM B62
43	Adjustment Screw	Stainless Steel	AISI 304

44	Jam Nut	Brass	ASTM B16
45	Pilot Valve Spring	Steel	AISI 1060
46	Upper Diaphragm Case	Cast Iron	ASTM A 126 CL B
		Cast Steel	ASTM A 216 WC B
47	Lower Diaphragm Case	Cast Iron	ASTM A 126 CL B
		Cast Steel	ASTM A 216 WC B
48	Spring Plate	Steel	ASTM A 569
49	Diaphragm	Stainless Steel	ASTM A 240
50	Diaphragm Plate	Brass	ASTM B36
51	Head & Seat Assembly	Stainless Steel	AISI 440
		Stainless Steel	AISI 440F
54	Diaphragm Case Screws	Steel 5/16" - 18 x 1"	ASTM A449
60	Pilot Gasket	Graphite	
61	Electric Solenoid Valve		
63	"T" Pilot Adaptor	Brass	ASTM B 62
64	Adaptor Pipe	Steel	ASTM A 53
65	"P" Pilot Adaptor	Ductile Iron	ASTM A 395
		Cast Steel	ASTM A 216 Gr WC B

Installation

The regulator should be installed in a horizontal line with suitable bypass and isolating valves. A steam trap should be installed upstream to prevent condensate from reaching the regulator. The trap and regulator should both be protected with a strainer separator set. The thermostatic bulb must be carefully located in the medium being heated. The pressure sensing line may be located either in the downstream piping or in the steam space. Complete installation instructions are given in IM-3-000-US.

Maintenance

Complete installation and maintenance instructions are given in IM-3-000-US and ADVP 3029, a copy of which is supplied with each regulator. Available spare parts are shown on TI-3-029-US and TI-3-0271-US.

TI-3-0181-US 06.10