

spirax sarco®

Combination Pressure/Temperature Regulator 1/2" to 4" 25PT

The 25PT eliminates the need for a separate pressure regulator and a temperature regulator. Normal operation is controlled by the temperature pilot, and the pressure pilot sets an upper limit on the downstream steam pressure. The temperature pilot has a calibrated dial for accurate temperature setting, and is available with a variety of solid-fill sensing bulbs (See TIS 1.1123). The standard capillary tubing length is 8 feet, with an optional standard length of 15 feet.

Model ↔	25PT			
Sizes	1/2" to 2"	2-1/2", 3", 4"	1/2" to 2"	2-1/2", 3", 4"
Connections	NPT	ANSI 125 figd.	NPT	ANSI 300 figd.
Construction	Cast Iron		Cast Steel	
Options		ANSI 250 figd.		ANSI 150 figd.
	Non-Standard capillary tubing length (see TIS 1.1123)			

Typical Applications

Storage steam water heaters, instantaneous heat exchangers and converters, air handling coils, tank heating coils, steam jacketed vessels, steam chests, molds and platens, and other temperature control applications where it is necessary or desirable to set an upper limit on the delivered steam pressure.

Capacities

The regulator is sized according to the temperature control requirements. For selection and sizing, see TI-1-1124-US.

Limiting Operating Conditions

Max. Operating Pressure (PMO)
 NPT: 250 psig (17 barg) @ 450°F (232°C)
 ANSI 125: 125 psig (8 barg) @ 450°F (232°C)
 ANSI 250: 250 psig (17 barg) @ 450°F (232°C)
 ANSI 150: 185 psig (12 barg) @ 450°F (232°C)
 ANSI 300: 300 psig (20 barg) @ 450°F (232°C)

Max. Operating Temperature
 450°F (232°C)

*The temperature of the sensing bulb must not exceed 350°F (177°C)

Standard Temperature Ranges

30°F to 90°F	0°C to 32°C		
60°F to 120°F	15°C to 50°C	160°F to 220°F	70°C to 105°C
100°F to 160°F	40°C to 70°C	200°F to 260°F	95°C to 125°C
120°F to 180°F	50°C to 80°C	260°F to 320°F	125°C to 160°C

Downstream Pressure Ranges

For the following downstream pressures, three color-coded pilot valve springs are available:

Yellow: 3 to 30 psi **Blue:** 20 to 100 psi **Red:** 80 to 290 psi

Pressure Shell Design Conditions

PMA Cast Iron: 250 psig/0-450°F 17 barg/0-232°C
 Max. allowable pressure Cast Steel: 600°F/0-300 psig 316°C/0-21 barg

TMA Cast Iron: 450°F/0-250 psig 232°C/0-17 barg
 Max. allowable temperature

Sample Specification

Pressure/Temperature Regulators shall be of the pilot-actuated, diaphragm-operated type with separate pressure and temperature pilots. The main valve shall be single-seated, with hardened stainless steel trim; the regulator shall be cast iron (cast steel). The pilots shall be removable without disturbing the control connections. The temperature setting shall be adjustable without the use of tools, and the set point shall be indicated on a calibrated dial. The thermostat system shall be solid fill, and shall incorporate overheat protection. The regulator shall be capable of dead-end shut-off.

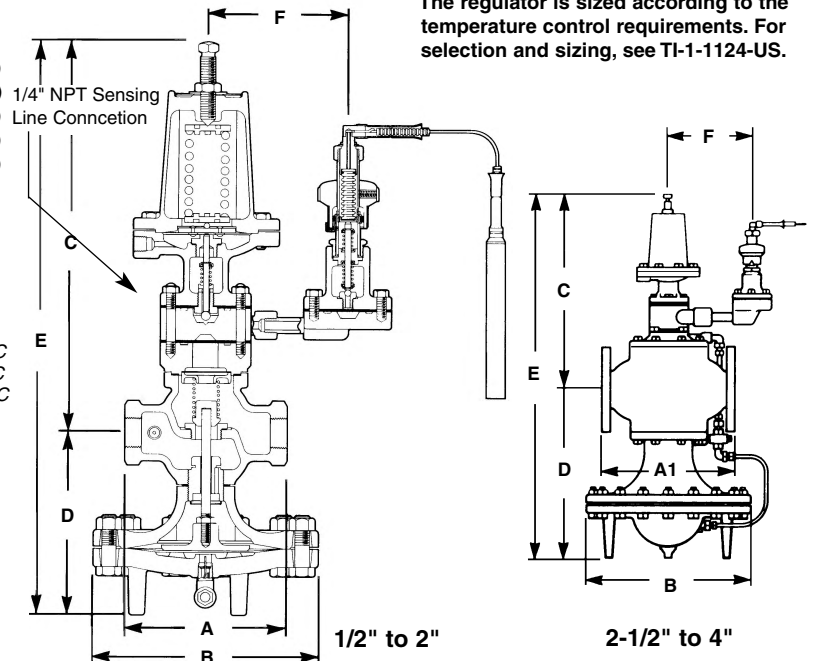

Dimensions (nominal) in inches and millimeters

Size	ANSI 125		ANSI 250		ANSI 300		WEIGHT			
	A	A1	A1	B	C	D	E	F	Cast Iron	Cast Steel
1/2", 3/4"	5.5	-	-	7.6	13.25	6.2	19.4	5.0	38 lb	41 lb
	140	-	-	194	337	157	494	127	17.2 kg	18.6 kg
1"	6.0	-	-	8.6	13.2	6.75	19.9	5.0	45 lb	49 lb
	152	-	-	219	335	171	506	127	20.4 kg	22.2 kg
1-1/4", 1-1/2"	7.25	-	-	8.6	13.75	7.1	20.8	5.0	50.5 lb	55 lb
	184	-	-	219	349	179	529	127	22.9 kg	25.0 kg
2"	8.5	-	-	10.6	14.4	8.2	22.6	5.0	75 lb	82 lb
	216	-	-	270	365	208	573	127	34 kg	37.2 kg
2-1/2"	-	10.9	11.5	13.6	15.1	13.9	29.0	5.0	163.5 lb	178 lb
	-	276	292	346	383	354	737	127	74.2 kg	80.7 kg
3"	-	11.75	12.5	13.6	15.0	14.4	29.4	5.0	194.5 lb	212 lb
	-	298	318	346	381	367	748	127	88.2 kg	96.2 kg
4"	-	13.9	14.5	15.6	16.3	16.1	32.4	5.0	290.5 lb	316 lb
	-	352	368	397	414	410	824	127	132 kg	143 kg

Local regulation may restrict the use of this product below the conditions quoted. Limiting conditions refer to standard connections only.

In the interests of development and improvement of the product, we reserve the right to change the specification.

TI-3-017-US 01.05

Combination Pressure/Temperature Regulator

1/2" to 4" 25PT

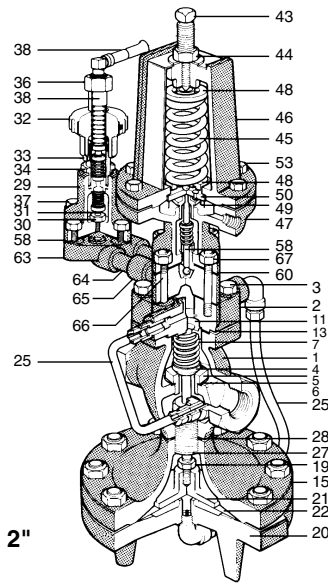

1/2" to 2"

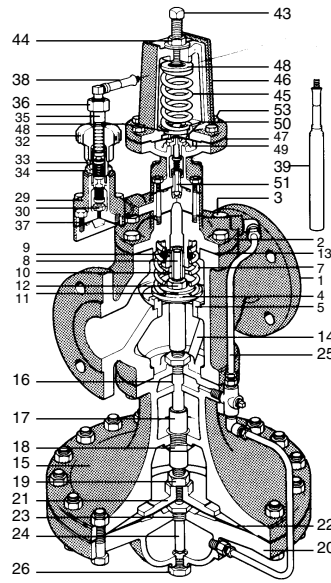

2-1/2" to 4"

Construction Materials

No.	Part	Material	
1	Valve Body	Cast Iron	ASTM A 126 CL B
		Cast Steel	ASTM A216 Gr WCB
2	Cover	Cast Iron	ASTM A 126 CL B
		Cast Steel	ASTM A216 Gr WCB
3	Cover Bolts	Steel	ASTM A449
4	Main Valve Head	Stainless Steel	
		1-1/2", 25 & 2" 25S	AISI 420
		all other sizes	AISI 420F
5	Main Valve Seat	Stainless Steel 1-1/2"-2"	AISI 420F
		2-1/2" - 4"	AISI 303
6	Main Valve Seat Gasket	Copper	ASTMB272
7	Valve Return Spring	Stainless Steel	AISI 631
8	Valve Stem	Stainless Steel	AISI 303
9	Strainer Screen	Stainless Steel	AISI 304
10	Valve Stem Sleeve	Stainless Steel	AISI 420F
11	Spring Guide	Cast Iron 1/2"-2"	ASTM A 126 CL B
		CRS 2-1/2" - 4"	AISI 1117
12	Nut	Steel	ASTM A307
13	Cover Gasket	Graphite	
14	Pressure Equalizer Pipe	Stainless Steel (2-1/2" - 4")	AISI 304
15	Upper Diaphragm Case	Cast Iron	ASTM A 126 CL B
		Cast Steel	ASTM A216 Gr WCB
16	Stem Bushing (2-1/2" - 4" Cast Steel only)	Stainless Steel	AISI 303
17	Diaphragm Plate Stem	Stainless Steel	AISI 304
18	Diaphragm Stem Guide	Stainless Steel	AISI 303
19	Nut	Brass 1/2" - 2"	ASTM B16
		Steel 2-1/2" - 4"	ASTM A307
20	Lower Diaphragm Case	Cast Iron	ASTM A 126 CL B
		Cast Steel	ASTM A216 Gr WCB
21	Diaphragm Plate	Brass 1/2" - 2"	ASTM B124 (377)
		C.I. 2-1/2" - 4"	ASTM A126 CL B
22	Main Diaphragm (2 ply)	Stainless Steel	ASTM A240
23	Bushing	CRS	AISI 1117
24	Tube & Orifice	Stainless Steel	AISI 304
25	Tubing Assembly	Copper	ASTM B280 (122)
		Brass	ASTM B16
26	Plug (Cast Iron) (Cast Steel)	Brass	ASTM B16
		Steel	ASTM A105
27	Connector Stud	Stainless Steel	AISI 303
28	Body Gasket	1/2" - 2" Copper Clad	Non-Asbestos Fill
		2-1/2" - 4" Graphite	
29	Pilot Valve Body	Cast Iron	ASTM A 126 CL B
		Cast Steel	ASTM A216 Gr WCB
30	Pilot Valve Seat	Stainless Steel	AISI 303
31	Pilot Valve Head	Stainless Steel	AISI 440A
32	Adjustment Knob	Phenolic	ASTM D 700 Ty2

33	Pointer	Stainless Steel	AISI 301
34	Extension Nut	Brass	ASTM B16
35	Case Tube	Brass	ASTM B 135 (330)
36	Retaining Nut	Brass	ASTM B 16
37	Pilot Mounting Screws	Steel	ASTM A449
38	Capillary Tube	Varies with style selected	
39	Bulb	Varies with style selected	
43	Adjustment Screw	Stainless Steel	AISI 303
44	Jam Nut	Brass	ASTM B16
45	Pilot Valve Spring	Steel	AISI 1060
46	Upper Diaphragm Case	Cast Iron	ASTM A 126 CL B
		Cast Steel	ASTM A216 Gr WCB
47	Lower Diaphragm Case	Cast Iron	ASTM A 126 CL B
		Cast Steel	ASTM A216 Gr WCB
48	Spring Plate	Steel	ASTM A569
49	Diaphragm	Stainless Steel	ASTM A240
50	Diaphragm PLate	Brass	ASTM B36
51	Pilot Head Spring	Stainless Steel	AISI Type 302
52	Spring Retainer Cup	Stainless Steel	AISI Type 301
53	Retaining Ring	Brass	ASTM B36
54	Pilot Seat	Stainless Steel	AISI Type 440F
55	Pilot Head	Stainless Steel	AISI Type 440
56	Head Stem	Stainless Steel	AISI Type 303
57	Stem Guide	Stainless Steel	AISI Type 303
58	Stem Guide Gasket	Stainless Steel	AISI Type 302
59	Seat Gasket	Stainless Steel	AISI Type 302
60	Pilot Gasket	Graphite	
61	Pilot Mounting Screws	Steel	ASTM A449
62	Diaphragm Case Screws	Steel/ 5/16" - 18 x 1"	ASTM A449
63	"T" Pilot Adapter	Brass	ASTM B62
64	Adapter Pipe	Steel	ASTM A53
65	"P" Pilot Adapter	Ductile Iron	ASTM A395
		Cast Steel	ASTM A216 Gr WCB
66	Adapter Stud	Steel	ASTM A193 Gr B7
67	Adapter Nut	Steel	SAE Grade 5

Installation

The regulator should be installed in a horizontal line with suitable bypass and isolating valves. A steam trap should be installed upstream to prevent condensate from reaching the regulator. The trap and regulator should both be protected with a strainer. The thermostatic bulb must be carefully located in the medium being heated. The pressure sensing line may be located either in the downstream piping or in the steam space. Complete installation instructions are given in IMI 650-D76.

Maintenance

Complete installation and maintenance instructions are given in IMI 650-D76, a copy of which is supplied with each regulator. Available spare parts are shown on TI-3-027-US and TI-3-0271-US.

TI-3-017-US 01.05