

spirax sarco®

TD62LM and TD62M Thermodynamic Steam Trap with replaceable seats

Description

The TD62LM and TD62M are maintainable high pressure thermodynamic steam traps with integral strainer and a replaceable seat to ease maintenance. They have been specifically designed for mains drainage applications up to 62 barg.

The TD62LM is specifically designed for relatively small condensate loads on superheat and mains drainage applications. An insulating cover is fitted as standard to prevent the trap being unduly influenced by excessive heat loss when subjected to low outside temperatures, wind, rain etc.

Model ⇄	TD62LM and TD62M
PMO	900 psig
Sizes	1/2", 3/4", 1"
Connections	SW to ANSI B16.11 Class 3000
Construction	Alloy Steel
Options	NPT Connections ANSI 300 / ANSI 600 Flanged Blowdown Valve (SW and NPT only)

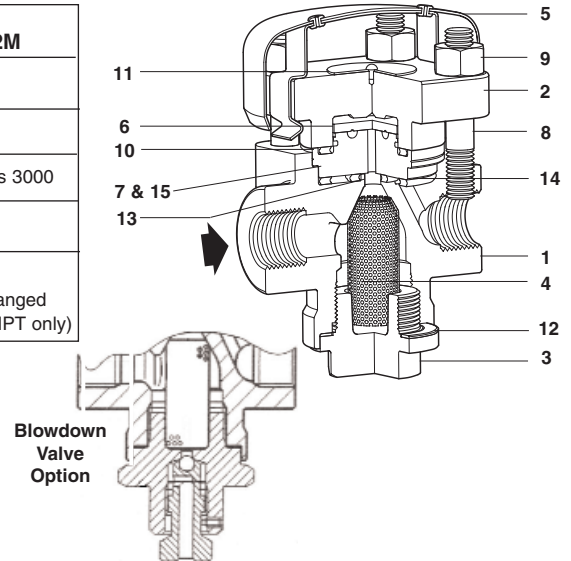

Capacities

Pressure		Hot Condensate Flow			
		TD62LM		TD62M	
psig	barg	#/hr.	kg.hr.	#/hr.	kg.hr.
25	2			293	133
50	3			422	192
100	7			552	250
120	8	167	76	586	266
150	10	185	84	628	285
200	14	212	96	682	309
250	17	235	107	724	328
300	21	256	116	758	344
350	24	274	124	786	357
400	28	292	132	811	368
500	34	324	147	853	387
550	38	338	153	871	395
600	41	352	160	887	402
650	45	366	166	902	409
700	48	378	172	916	415
750	52	391	177	929	421
800	55	402	183	941	427
850	59	414	188	952	432
900	62	425	193	963	437

Materials

No.	Part	Material
1	Body	Steel
2	Cover	Steel
3	Strainer cap	Steel
4	Strainer screen	Stainless steel 100 mesh 316L
5	Insulating cover	Aluminium
6	Disc	Chromium steel
7	Seat	Chromium steel
8	Cover studs	Steel
9	Cover nuts	Steel
10	Cover gasket	Spirally wound stainless steel with exfoliated graphite filler
11	Name-plate	Stainless steel
12	Strainer cap gasket	Reinforced exfoliated graphite
13	Inner seat gasket	Spirally wound stainless steel with exfoliated graphite filler
14	Outer seat gasket	Spirally wound stainless steel with exfoliated graphite filler
15	Ferrule	Stainless steel

* Note: Item 15 (ferrule) is pressed into item 7 (seat).

Operating Range (SW Connection Only)

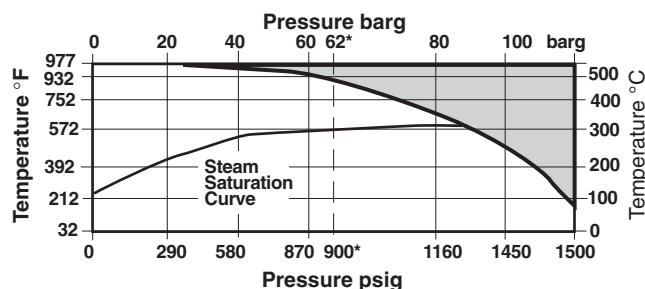

The product must not be used in this region

* PMO — Max. operating pressure recommended
PMOB — Max. operating back pressure 80% of upstream pressure

Limiting Conditions

Body design conditions ANSI 600

PMA — Max. allowable pressure 1500 psig 103 barg
TMA — Max. allowable temperature 977°F 525°C
Cold hydraulic test pressure 2250 psig 155 barg

TD62LM

Minimum pressure for satisfactory operation is 120 psig, 8 barg.
Maximum back pressure should not exceed 50% of the inlet pressure under any conditions of operation, otherwise the trap may not shut.

TD62M

Minimum pressure for satisfactory operation is 20 psig, 1.4 barg.
Maximum back pressure should not exceed 80% of the inlet pressure under any conditions of operation, otherwise the trap may not shut.

Local regulation may restrict the use of this product below the conditions quoted. Limiting conditions refer to standard connections only.

In the interests of development and improvement of the product, we reserve the right to change the specification.

TD62LM and TD62M Thermodynamic Steam Trap with replaceable seats

Socket Weld / NPT

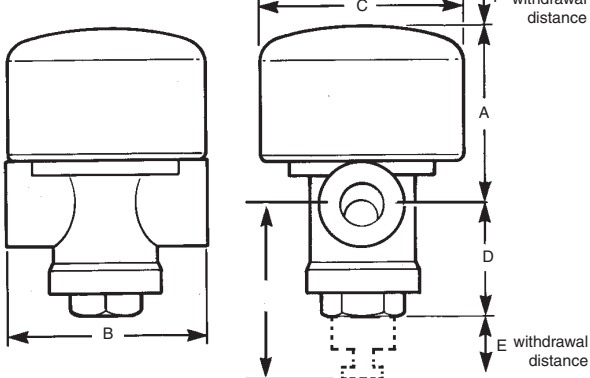

Dimensions (nominal) in inches and millimeters

Size	A	B	C	D	D ₁ *	E	F	Weight
1/2", 3/4"	3.1 79	3.6 92	3.6 92	2.0 51	3.3 84	0.8 20	2.0 51	4.6 lb 2.1 kg
1"	3.3 84	3.9 100	3.6 92	1.8 46	3.1 79	0.8 20	2.0 51	5.3 lb 2.4 kg

* Traps with blowdown valve

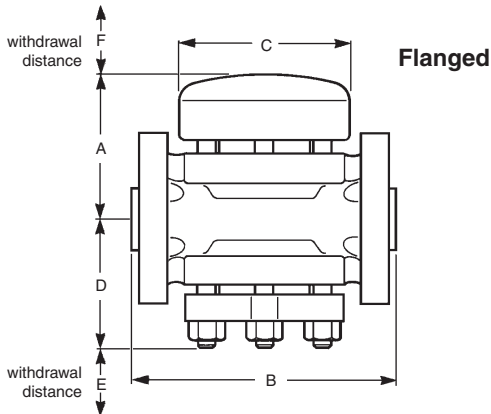

Dimensions (nominal) in inches and millimeters

Size	ANSI 600		ANSI 300		C	D	E	F	Weight
	A	B1	B2						
1/2"	3.2 82	5.9 150	5.3 135	3.6 92	2.8 72	1.6 40	1.2 30	18.7 lb 8.5 kg	
3/4"	3.2 82	5.9 150	5.4 138	3.6 92	2.8 72	1.6 40	1.2 30	18.7 lb 8.5 kg	
1"	3.2 82	6.3 160	5.8 147	3.6 92	2.8 72	1.6 40	1.2 30	20.0 lb 9.1 kg	

Sample Specification

Spirax Sarco TD62M ThermoDynamic® steam trap, available in sizes 1/2", 3/4", and 1" socket weld connections to ANSI B16.11 Class 3000 (or NPT or ANSI 300 or 600 flanged connections). Alloy steel construction, suitable for operation from 20 to 900 psig at a maximum operating temperature of 842°F. An integral strainer and insulating cover are standard. Traps to have replacement seats and disc.

Installation

The preferred trap installation is in a horizontal pipe with the insulcap up. After 24 hours in service the cover nuts should be checked for tightness and if necessary torqued to 33-37 ft•lb. Full-port isolating valves should be installed upstream and downstream of the trap.

Spare Parts

Socket Weld / NPT

Flanged

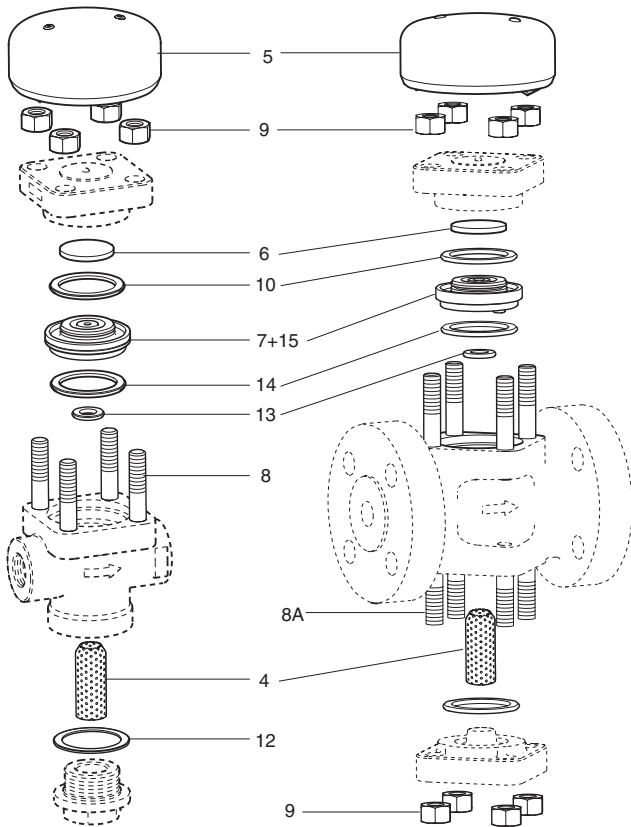

Spare Parts

The spare parts available are shown in solid outline. Parts shown in broken line are not supplied as spares.

Available spares

Insulating cover		5
Set of cover studs and nuts (set of 8) on FCC	4 on other	8, 8A, 9
Seat and disc assembly	6, 7, 10, 13, 14, 15	
Strainer screen 100 mesh		4
Cover gasket (packet of 3 sets) Flanged		10,13,14
Set of gaskets (packet of 3 sets) SW, NPT		10,12,13,14

How to order spares

Always order spares by using the description given in the column headed "Available spares" and state the size and type of trap.

Example: 1- Strainer screen for a Spirax Sarco 1" TD62LM thermodynamic steam trap (ASTM body)

Maintenance

This product can be maintained without disturbing the piping connections. Complete isolation of the trap from both supply and return line is required before any servicing is performed.

The trap should be disassembled periodically for cleaning of the strainer screen and inspection and cleaning of the disc and seat.

Complete installation and maintenance instructions are given in the IMI Sheet, which accompanies the product. (IM-P068-58)

TI-2-525-US 08.06