

spirax sarco®

Thermo-Dynamic® Steam Trap TDC

The **Thermo-Dynamic® steam trap** cycles periodically to discharge condensate very near to steam temperature. It is unaffected by waterhammer or superheat.

Model ⇄	TDC
PMO	600 psig
Sizes	3/8", 1/2", 3/4", & 1"
Connections	NPT
Construction	Stainless Steel

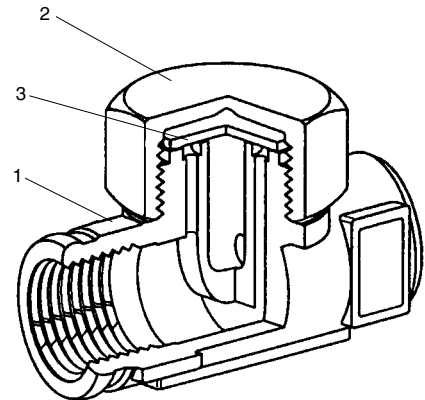

Capacities

Pounds of condensate per hour
continuous discharge at saturated steam temperature to atmosphere

Inlet Pressure		3/8" TDC	1/2" TDC	TDC 3/4"	TDC 1"
psig	barg				
3.5	.24	180	300	405	640
5	.34	185	310	420	670
10	.69	190	345	470	725
20	1.4	200	410	560	865
30	2.1	215	465	640	980
50	3.5	245	575	810	1200
75	5.2	305	700	1000	1470
100	6.9	370	810	1160	1750
150	10.3	500	1000	1450	2200
200	13.8	610	1140	1670	2600
250	17.2	700	1270	1900	2900
300	20.7	790	1410	2100	3250
350	24.1	880	1530	2250	3500
400	27.6	960	1630	2430	3780
450	31.0	1050	1730	2600	4020
500	34.5	1100	1830	2750	4250
550	37.9	1160	1910	2900	4450
600	41.4	1250	2000	3050	4700

Construction Materials

No.	Part	Material	
1	Body	Stainless Steel	ASTM A743 GR. CA40F
2	Cap	Stainless Steel	ASTM A743 GR. CA40F
3	Disc.	Stainless Steel	AISI 420

Limiting Operating Conditions

Max. Operating Pressure (PMO) 600 psig (42 barg)

Max. Operating Temperature 800°F (427°C) at all operating pressures

Minimum pressure for satisfactory operation is 3.5 psig, (0.24 barg)

Maximum back pressure should not exceed 80% of the inlet pressure under any conditions of operation, otherwise the trap may not shut.

Pressure Shell Design Conditions

PMA 600 psig/up to 800°F
Max. allowable pressure 42 barg/up to 427°C

TMA 800°F/0-600 psig
Max. allowable temperature 427°C/0-42 barg

Typical Applications

Steam main drainage and tracer lines, process equipment, laundry and kitchen equipment, superheated steam applications, outdoor installations subject to freezing.

Thermo-Dynamic® Steam Trap TDC

Dimensions (nominal) in inches and millimeters							
Size	A	B	C	D	E	F	Weight
3/8" TDC	2 50.8	1.7 43.2	1.7 43.2	1 25.4	1.03 26.2	0.4 10.2	.7 lb .24 kg
1/2" TDC	2.7 68.6	1.7 43.2	2 50.8	1.2 30.5	1.24 31.5	0.4 10.2	0.9 lb .41 kg
3/4" TDC	2.8 71.1	2.1 53.3	2.4 61.0	1.5 38.1	1.56 39.6	0.4 10.2	1.8 lb .82 kg
1" TDC	3.3 83.8	2.5 65.5	2.8 71.1	1.8 45.7	1.87 47.5	0.6 15.2	2.7 lb 1.22 kg

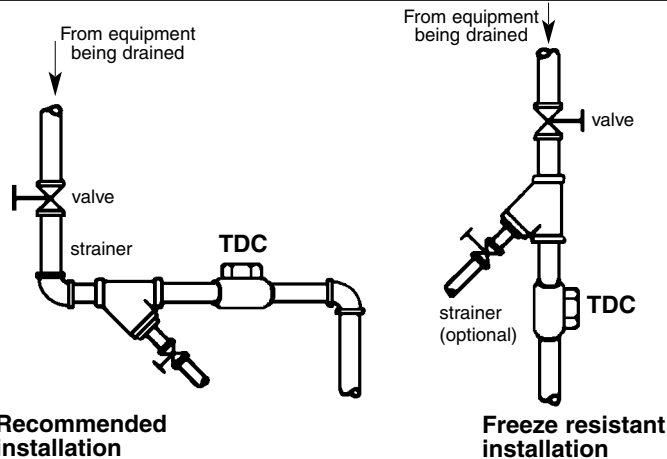
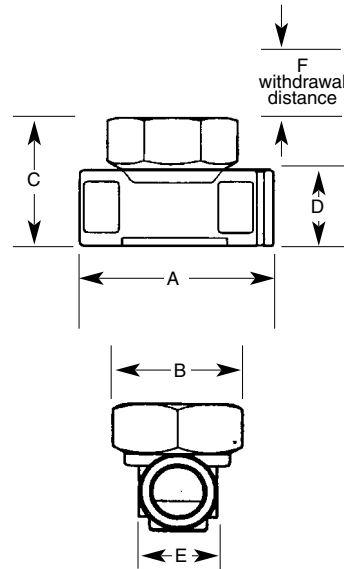

Installation

The preferred installation is in the horizontal position as close as possible to equipment being drained. Install strainer (20 mesh) upstream and full port isolating valves upstream and downstream of trap. Piping to and from the trap should be at least equal to or one size larger than trap connection. Do not weld pipe connection to trap. Body material is not suitable for welding.

For freeze resistant installations, all drains must be pitched toward the trap for gravity flow. Trap must be installed vertically, discharging downward. Discharge piping must be self-draining.

Sample Specification

Steam trap shall be all stainless steel Thermo-Dynamic® disc type with connections on a common center line, which will operate in any position. Integral seat design with hardened disc and seating surfaces. Trap to have intergral insul-cap and three hole balanced discharge.

Maintenance

This product can be maintained without disturbing the piping connections. Complete isolation of the trap from both supply and return line is required before any servicing is performed.

The trap should be disassembled periodically for inspection and cleaning of the disc and seat.

The only wearing parts of the trap are the disc and seat rings, which should be inspected and cleaned periodically. Slight wear can often be corrected by resurfacing on a lapping plate.

Caution: Only perform maintenance after trap has been isolated.

Complete installation and maintenance instructions are given in IMI 2.5162, which accompanies the product.

