

spirax sarco®

Stainless Steel Float & Thermostatic Steam Trap FT 46

The FT 46 is a stainless steel float trap designed for applications requiring continuous drainage of high condensate loads in filtered steam applications.

Model	FT 46 - 4.5	FT 46 - 10	FT 46 - 14	FT 46 - 21
PMO	65 psig	145 psig	200 psig	300 psig
Sizes	1", 1-1/2", 2"			
Connections	ANSI 150, 300			
Construction	AISI 316 Stainless Steel Body, Stainless Steel Internals			
Options	3/8" NPT Drain Cock Tapping			

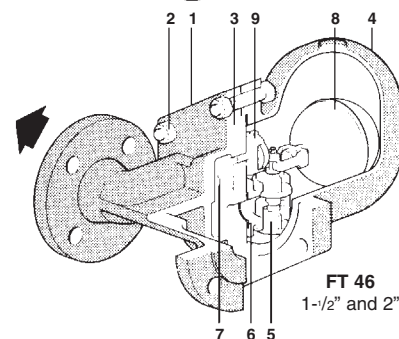
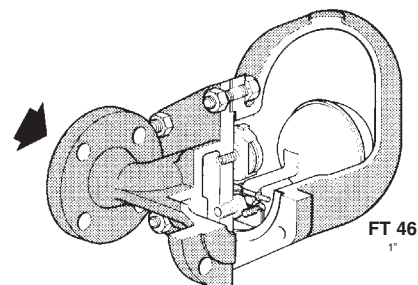

Construction Materials

No.	Part	Material	
1	Body	Stainless Steel	AISI 316
2	Cover Bolts 1"	Stainless Steel	Class A2 Gr80
		M10 x 60 mm	
	1-1/2", 2"	M16 x 85 mm	
3	Cover Gasket	Stainless Steel	BS 1449 304 S16
4	Cover	Stainless Steel	AISI 316
5	Valve Seat 1"	Stainless Steel	BS 970 431 S29
		Main Valve Assembly w/ Erosion Deflector 1-1/2", 2"	Stainless Steel BS 3146 Pt2 type ANC2 BS 970 416 S37
6	Valve Seat Gasket 1"	Stainless Steel	BS 1449 304 S11
		Main Valve Assembly Gasket 1-1/2", 2"	Stainless Steel AISI 316
7	Pivot Frame Assmbley Set Screws 1"	Stainless Steel	
		M5 x 20 mm	BS 4183 18/8
	Main Valve Assembly Bolts 1-1/2"	Stainless Steel	
		M6 x 20 mm	BS 970 304 S15
	Studs & Nuts 2"	M8 x 20 mm	BS 6105 A4.80
8	Ball Float & Lever	Stainless Steel	BS 1449 304 S16
9	Air Vent	Stainless Steel	
11	Support Frame	Stainless Steel	BS 1449 304 S16
12	Pivot Frame	Stainless Steel	BS 1449 304 S16

Capacities

Refer to TIS 2.308

Typical Applications

Removal of filtered steam condensate from heating jackets, heat exchangers, large process vessels, steam filters, separators, and humidifiers.

Limiting Operating Conditions

Max. Operating Pressure (PMO)	FT46-4.5: 65 psig (4.5 barg)
	FT46-10: 145 psig (10 barg)
	FT46-14: 200 psig (14 barg)
	FT46-21: 300 psig (21 barg)
Max. Operating Temperature	45°F (25°C) of Superheat at all operating pressures

Pressure Shell Design Conditions

PMA Max. allowable pressure	580 psig/0-248°F	40 barg/0-120°C
	472 psig/464°F	32 barg/240°C
	304 psig/752°F	21 barg/400°C
TMA Max. allowable temperature	752°F/0-304 psig	400°C/0-21 barg

Local regulation may restrict the use of this product below the conditions quoted. Limiting conditions refer to standard connections only.
In the interests of development and improvement of the product, we reserve the right to change the specification.

TI-2-318-US 9.08

Stainless Steel Float & Thermostatic Steam Trap FT 46

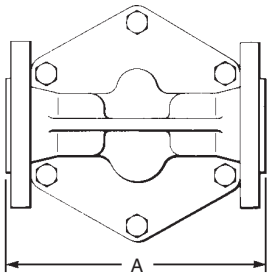

Dimensions
(nominal) in inches and millimeters

Size/DN	A	B	C	D	E	Weight
1" 25	6.2 160	4.5 115	3.4 85	10.8 276	6.7 170	33 lb 15 kg
1-1/2" 40	9.0 230	4.8 130	4.5 115	12.7 326	7.9 200	72.8 lb 33 kg
2" 50	9.0 230	5.5 141	4.8 123	12.9 332	7.9 200	94.8 lb 43 kg

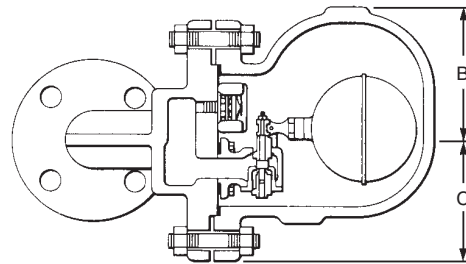
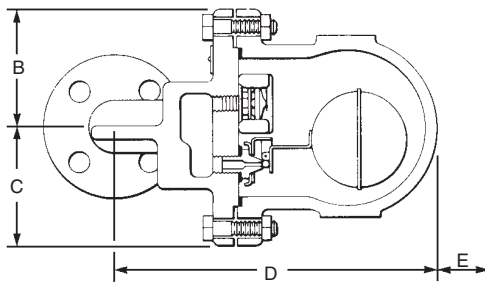

NOTE: Flanges drilled and tapped

Installation

The trap must be fitted with the direction of flow as indicated on the body, and with the float arm in a horizontal plane so that it rises and falls vertically. Full-flow isolating valves should be installed upstream and downstream of the trap.

Sample Specification

Float & Thermostatic traps for pharmaceutical sterile areas on plant or clean steam service shall have 316L stainless steel bodies and covers, and all internals, including float, main valve, head/seat, thermostatic air vent and air vent head/seat, shall be stainless steel. Connections shall be in-line horizontal. ANSI flanged Spirax Sarco Model FT 46.

Maintenance

This product can be maintained without disturbing the piping connections. Complete isolation from both supply and return line is required before any servicing is performed.

The trap should be disassembled periodically for inspection and cleaning of the valve head and seat, operating mechanism and air vent.

Worn or damaged parts should be replaced using a complete main valve assembly and/or air vent assembly.

Complete installation and maintenance instructions are given in the IMI sheet, which accompanies the product.

Spare Parts

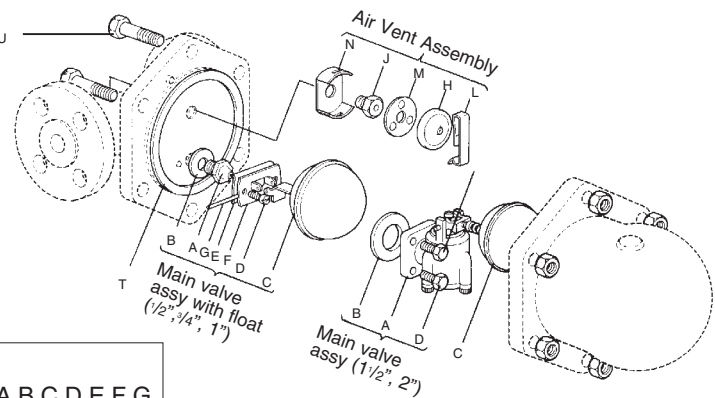

Main Valve Assembly w/ Float	A,B,C,D,E,F,G
Main Valve Assembly w/ Erosion Deflector (1-1/2", 2")	A,B,D
Ball Float (1")	C
Air Vent Assembly	H, J, L, M, N
Three complete sets of Gaskets (Pkt of 3 sets)	B,K,P,R,T
Set of Cover Bolts & Nuts	U

TI-2-318-US 9.08