

spirax/sarco®

Cast Iron Float & Thermostatic Steam Traps FT-150, FT-200

The trap contains a float valve mechanism which modulates to discharge condensate continuously at steam temperature, while non-condensable gases are released by a separate internal balanced pressure thermostatic air vent.

Model →	FT-150	FT-200
PMO	150 psig	200 psig
Sizes	3/4", 1", 1-1/4", 1-1/2"	
Connections	NPT	
Construction	Cast Iron Body & Cover Stainless Steel Internals	
Option	Gauge Glass Vacuum Breaker	

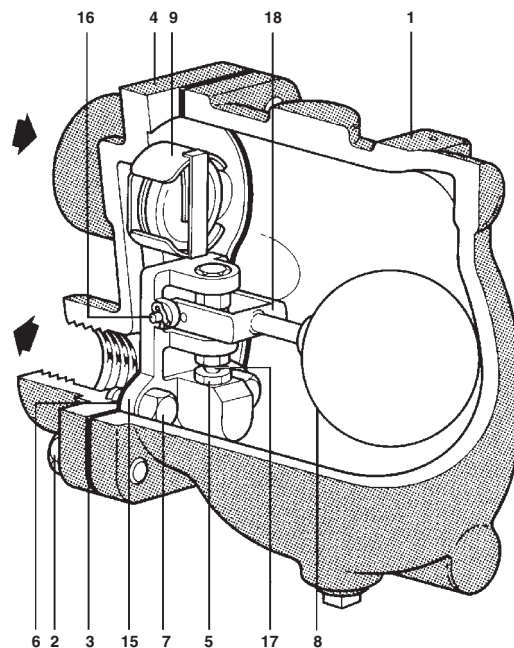

LIMITING OPERATING CONDITIONS

Max. Operating Pressure (PMO) FT-150: 150 psig (10.3 barg)
FT-200: 200 psig (13.8 barg)

Max. Operating Temperature 45°F (25°C) of Superheat at all operating pressures

PRESSURE SHELL DESIGN CONDITIONS

PMA 200 psig/up to 450°F 13.8 barg/up to 232°C
Max. allowable pressure

TMA 450°F/0-200 psig 232°C/0-13.8 barg
Max. allowable temperature

TYPICAL APPLICATIONS

All process equipment, particularly when controlled by modulating temperature control valves, unit heaters, air heating coils, heat exchangers and steam main drip stations

For Capacities, see TIS 2.317.

CONSTRUCTION MATERIALS

No.	Part	Material	
1	Body	Cast Iron	ASTM A126 CL B
2	Cover Screws	Carbon Steel	ASTM A449
3	Cover Gasket	Graphite	
4	Cover	Cast Iron	ASTM A126 CL B
5	Valve Seat	Stainless Steel	Type 303
6	Main Valve Assy Gasket	Graphite	
7	Main Valve Assy Screws	Copper Alloy	Everdur 1015
8	Ball Float	Stainless Steel	Type 304
9	Air Vent Assembly	Stainless Steel	
	Air Vent Head	Stainless Steel	Type 440 GR B
	Air Vent Seat	Stainless Steel	Type 303
15	Main Valve Assy Housing	Cast Red Brass	ASTM B62 (85-5-5-5)
16	Pivot Pin	Stainless Steel	Type 303
17	Valve Head	Stainless Steel	Type 303
18	Float Arm	Forged Brass (3/4", 1") Cast Red Brass (1-1/4", 1-1/2")	ASTM B124 Alloy 377 ASTM B62 (85-5-5-5)

Local regulation may restrict the use of this product below the conditions quoted. Limiting conditions refer to standard connections only.
In the interests of development and improvement of the product, we reserve the right to change the specification.

Iron Float & Thermostatic Steam Traps

FT-150, FT-200

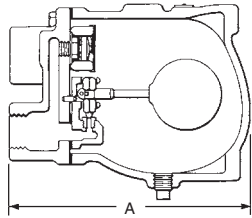
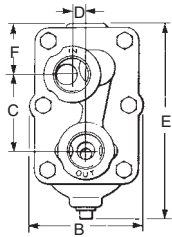

DIMENSIONS (NOMINAL) IN INCHES AND MILLIMETERS							
Size	A	B	C	D	E	F	Weight
3/4", 1"	8.5 216	3.9 100	2.6 65	0.4 9	6.9 175	1.8 46	15 lb 6.8 kg
1-1/4", 1-1/2"	10.75 273	5.75 146	3 76	0.6 14	9.1 232	2.5 64	30 lb 13.6 kg

SAMPLE SPECIFICATION

Steam traps shall be of the mechanical ball float type having cast iron bodies, NPT connections, and stainless steel valve heads and seats. Incorporated into the trap body shall be a stainless steel balanced pressure thermostatic air vent capable of withstanding 45°F (25°C) of superheat and resisting waterhammer without sustaining damage. Internals of the trap shall be completely servicable without disturbing the piping.

INSTALLATION

A pipeline strainer should be installed ahead of any steam trap. Full port isolating valves should be placed to permit servicing. The trap should be installed below the drainage point of the equipment with a collecting leg before the trap, in a position so that the float arm is in a horizontal plane and the float rises and falls vertically, with the flow direction as indicated on the cover. Refer to IMI 2.300 for complete instructions.

MAINTENANCE

This product can be maintained without disturbing the piping connections. Complete isolation from both supply and return line is required before any servicing is performed.

The trap should be disassembled periodically for inspection and cleaning of the valve head and seat, operating mechanism and air vent.

Worn or damaged parts should be replaced using a complete valve mechanism assembly and/or air vent assembly.

Complete installation and maintenance instructions are given in IMI 2.300, which accompanies the product.

SPARE PARTS

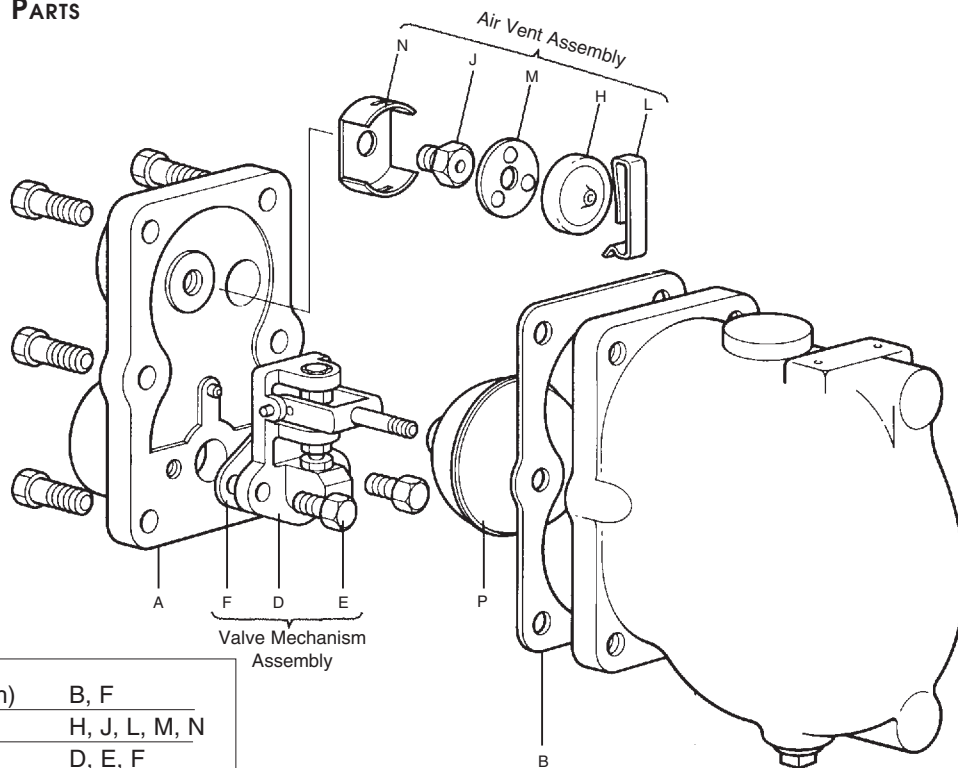

Gasket Kit (3 of each)	B, F
Air Vent Kit	H, J, L, M, N
Valve Mechanism Kit (less float)	D, E, F
Float Kit	P