

spirax/sarco®

Thermo-Dynamic® Steam Trap TDT Tracer Trap

The Thermo-Dynamic® steam trap cycles periodically to discharge condensate at a subcooled temperature. It is unaffected by waterhammer or superheat. Specifically designed as a tracing trap.

Model ⇄	TDT
PMO	150 psig
Sizes	1/2"
Connections	NPT
Construction	stainless steel

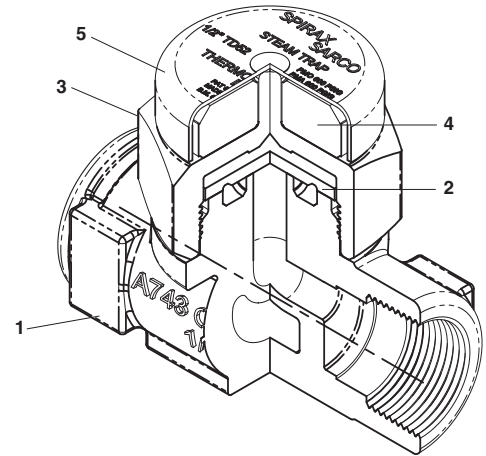

Capacities

Pressure psig	Pressure barg	Cold Water lb/hr.	Hot Condensate lb/hr.
10	0.69	440	75
20	1.4	550	100
30	2.1	630	100
50	3.5	830	100
75	5.2	1000	100
100	6.9	1190	100
125	8.6	1340	100
150	10.3	1445	100

Limiting Operating Conditions

Max. Operating Pressure (PMO) 150 psig (10 barg)

Max. Operating Temperature 800°F (427°C) at all operating pressures

Minimum pressure for satisfactory operation is 5 psig, (0.35 barg).

Maximum back pressure should not exceed 80% of the inlet pressure under any conditions of operation, otherwise the trap may not shut.

Condensate Flow

Average Operating Subcool Below Saturation

< 50 lb/hr	34°F
< 100 lb/hr.	50°F

Pressure Shell Design Conditions

PMA 600 psig/up to 800°F 42 barg/up to 427°C
Max. allowable pressure

TMA 800°F/0-600 psig 427°C/0-42 barg
Max. allowable temperature

Typical Tracer Output for 100ft @ 40°F Product Temperature

Pressure psig barg	3/8" nom. .50 OD	1/2" nom. .625 OD	3/4" nom. .875 OD	1" nom. 1.125 OD
15	15	18	25	33
25	16	20	28	36
50	19	23	32	42
100	22	28	39	50
150	25	31	44	56

Typical Applications

Tracer lines and application where subcooling condensate is desired.

Thermo-Dynamic® Steam Trap

TDT Tracer Trap

Dimensions (nominal) in inches and millimeters							
Type	A	B	C	D	E	F	Weight
1/2" TD52L	2.7 68.6	1.24 31.5	2.5 63.5	1.7 43.2	1.2 30.4	.4 10.2	1.2 lbs .54 kg

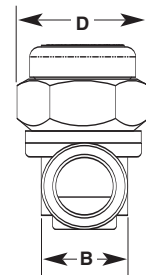
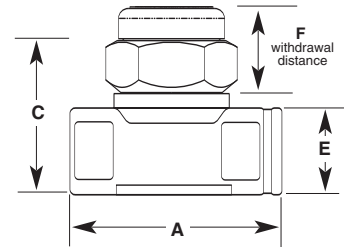

Construction Materials

No.	Part	Material
1	Body	Stainless Steel (with ENP) ASTM A743 GR. CA40F
2	Disc	Stainless Steel AISI 420
3	Cap	Stainless Steel (with ENP) ASTM A743 GR. CA40F
4	Insulator	Ceramic
5	Nameplate Cover	Stainless Steel Type 304

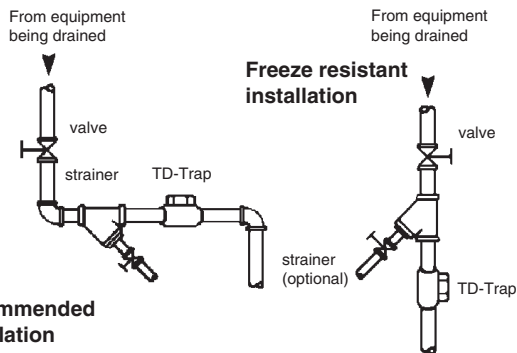

Recommended installation

Installation

The preferred installation is in the horizontal position as close as possible to equipment being drained. Install strainer (20 mesh) upstream and full port isolating valves upstream and downstream of trap. Piping to and from the trap should be at least equal to or one size larger than trap connection. Do not weld pipe connection to trap. Body material is not suitable for welding. For freeze resistant installations, all drains must be pitched toward the trap for gravity flow. Trap must be installed vertically, discharging downward. Discharge piping must be self-draining.

Sample Specification

Steam trap shall be all stainless steel thermo-Dynamic® disc type with connections on a common center line, which will operate in any position. Integral seat design with hardened disc and seating surfaces. Trap to have integral insulating cap.

Maintenance

This product can be maintained without disturbing the piping connections. Complete isolation of the trap from both supply and return line is required before any servicing is performed. The trap should be disassembled periodically for inspection and cleaning of the disc and seat. The only wearing parts of the trap are the disc and seat rings, which should be inspected and cleaned periodically. Slight wear can often be corrected by resurfacing on a lapping plate.

Caution: Only perform maintenance after trap has been isolated.

Complete installation and maintenance instructions are given in IMI 2.516, which accompanies the product.

Spare Parts

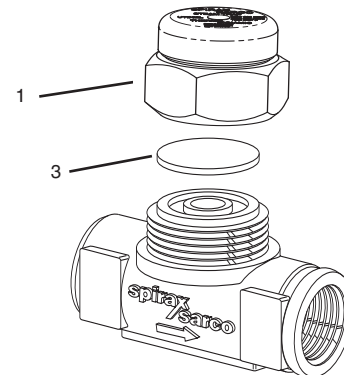

Disc	3
Cap Assembly	1