

spirax sarco®

Balanced Pressure Thermostatic Steam Trap SBP30LC

The welded stainless steel element is self-adjusting over the entire operating pressure range and will discharge condensate at approximately 18°F (10°C) below saturated steam temperature. The element is resistant to waterhammer, and up to 90°F (50°C) superheat over saturated steam temperature can be tolerated by this trap.

Model ⇄	SBP30LC
PMO	435 psig
Sizes	1/2" & 3/4"
Connections	NPT
Construction	All Stainless Steel tamper-proof body
Options	S.W. & BSP connections Subcooling capsule filling

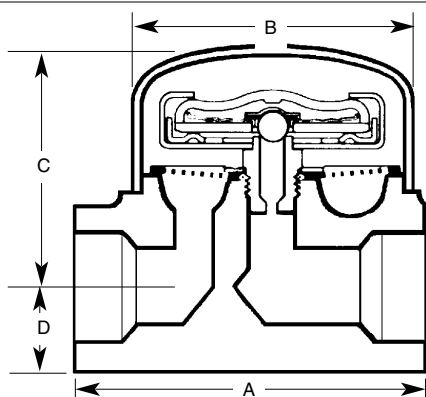
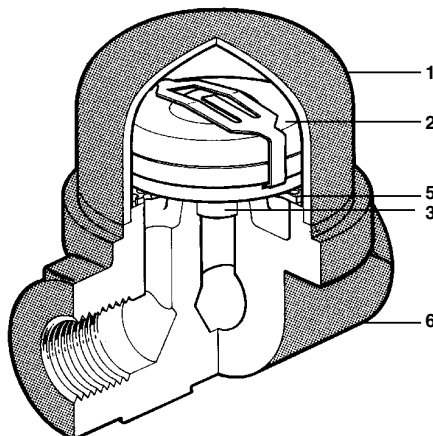

DIMENSIONS (NOMINAL) IN INCHES AND MILLIMETERS

Size	A	B	C	D	Weight
1/2", 3/4"	3.1 80	2.5 63	2.2 56	0.74 19	2.2 lb 1.0 kg

TYPICAL APPLICATIONS

Kitchen and hospital equipment, steam tracers, steam coils, steam radiators and steam main drip stations.

LIMITING OPERATING CONDITIONS

Max. Operating Pressure (PMO) 435 psig (30 barg)

Max. Operating Temperature 500°F (260°C) at 435 psig (30 barg)
545°F (285°C) at operating pressures below 426 psig (29 barg)

PRESSURE SHELL DESIGN CONDITIONS

PMA 720 psig/up to 100°F 50 barg/up to 38°C
Max. allowable pressure 450 psig/459°F 31 barg/237°C
400 psig/752°F 27 barg/426°C

TMA 752°F/0-400 psig 400°C/0-27 barg
Max. allowable temperature

CAPSULE FILLING

As standard, the trap is supplied with filling **D**, which will operate approximately 18°F (10°C) below steam temperature.

As an option, the trap can be supplied with filling **C**, which will operate approximately 36°F (20°C) below steam temperature, i.e. sub-cooling.

Note: If the alternative capsule is required, this must be clearly stated on the order, e.g. Capsule to have **C** fill.

CONSTRUCTION MATERIALS

No.	Part	Material	
1	Cover*	Stainless Steel	ASTM A240 Gr 304
2	Capsule	Stainless Steel	AISI 321
2A	Element Valve	Stainless Steel	AISI 440
3	Seat Assembly	Stainless Steel	AISI 431
4	Valve Seat Gasket	Stainless Steel	AISI 304
5	Strainer Screen	Stainless Steel	AISI 304
6	Body*	Stainless Steel	ASTM A473 Gr 304

* The body/cover weld joint complies with ASME section IX and BS4870 (1981).

Local regulation may restrict the use of this product below the conditions quoted. Limiting conditions refer to standard connections only.

In the interests of development and improvement of the product, we reserve the right to change the specification.

TI-2-0061-US 09.97

Balanced Pressure Thermostatic Steam Trap SBP30LC

SAMPLE SPECIFICATION

Steam trap shall be encapsulated Spirax Sarco SBP30LC balanced pressure thermostatic type, which self-adjusts to all pressures to 435 psig and can be installed in either horizontal or vertical piping. Maintenance-free and tamper-proof design of all stainless steel construction with forged body and drawn cover completely sealed against leakage. Operating element to be a solidly liquid-filled thermostatic capsule which vents air freely, operates close to steam temperature, resists waterhammer and freezing conditions, and can withstand up to 90°F superheat.

INSTALLATION

Although the trap will operate in any position, the preferred installation is in a horizontal pipe with a drop leg immediately before the trap. The electric arc process must be used when the SW trap is welded into the pipeline. Full port isolating valves should be installed unstream and downstream of the trap.

MAINTENANCE

This product is factory sealed for tamper-proof operation, and no repair parts are available. Complete isolation from both supply and return line is required before the trap is removed.

Complete installation and maintenance instructions are given in the IMI sheet, which accompanies the product.

CAPACITIES

