

# spirax/sarco®

## Vent Head Type VH

Spirax Sarco Vent Heads type VH are designed for fitting to vertical open-ended steam vent pipes. The vent head will discharge dry steam at low velocity safely to atmosphere protecting personnel from injury and buildings from material damage. The vent head incorporates an internal baffle to separate entrained water from the steam and discharges separately through the drain connection.

Model ⇄	VH 2S-VH 3S	VH 3-VH 12
Sizes	2" and 3"	3" - 12"
Vent Connection	NPT	ANSI 150
Drain Connection	NPT	
Construction	Stainless Steel	Stainless Steel Flange - Plated Steel

### TYPICAL APPLICATIONS

Vent heads type VH are ideal for condensate tanks, blowdown vessels, boiler feedtanks, deaerators, hot water storage tanks, etc. *Caution:* Vent heads are not recommended for safety valve outlets.

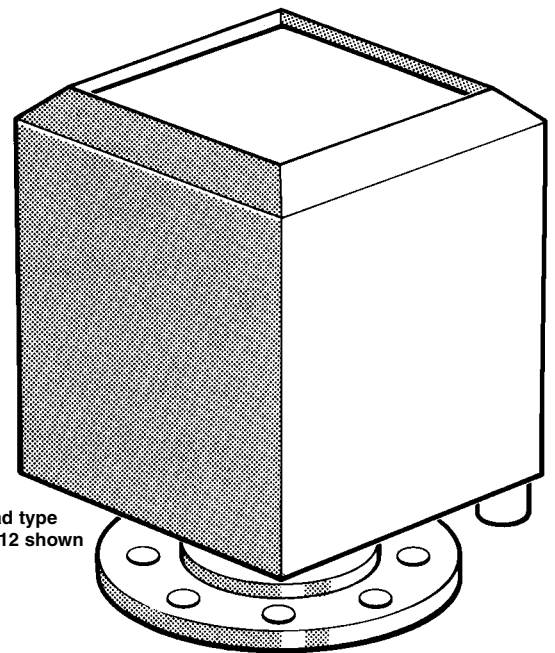

Vent Head type  
VH 3 — VH 12 shown

### AVAILABLE TYPES

Vent heads are available as types VH 2S, 3S, 3, 4, 6, 8, 10 and 12. The vent head should be selected so that it is the same nominal size as the vent pipe, when sized for a maximum velocity of 3500 ft/min at atmospheric pressure.

### MATERIALS

300 grade austenitic stainless steel except the flange (VH 3–VH 12 only) which is electroplated carbon steel

### SAMPLE SPECIFICATION

Vent head shall be baffle type, manufactured in stainless steel with threaded drain connection. Flanged units shall have a lap type flange to allow rotation and easy orientation of the drain connection during installation.

### INSTALLATION

The lap joint flange allows rotation and easy orientation of the drain connection. The drain should be piped to a safe position. An annual inspection is recommended to ensure that the outlet drain connection is unobstructed.

### DIMENSIONS (NOMINAL) IN INCHES AND MILLIMETERS

Vent Head Type	Inlet size	Drain Size	H	W	Weight
VH 2S	2"	3/4" NPT	8.3	6.0	4.4 lb
	50		210	152	2.0 kg
VH 3S	3"	3/4" NPT	10.6	8.0	5.5 lb
	80		270	202	2.5 kg
VH 3	3"	3/4" NPT	12.0	8.6	12.0 lb
	80		305	218	5.5 kg
VH 4	4"	1" NPT	12.6	9.5	13.0 lb
	100		320	240	6.0 kg
VH 6	6"	1" NPT	15.4	13.4	29.0 lb
	150		390	340	13.0 kg
VH 8	8"	1-1/2" NPT	16.9	16.7	44.0 lb
	200		430	425	20.0 kg
VH 10	10"	1-1/2" NPT	19.5	20.7	62.0 lb
	250		495	525	28.0 kg
VH 12	12"	2" NPT	22.4	24.6	77.0 lb
	300		570	625	35.0 kg

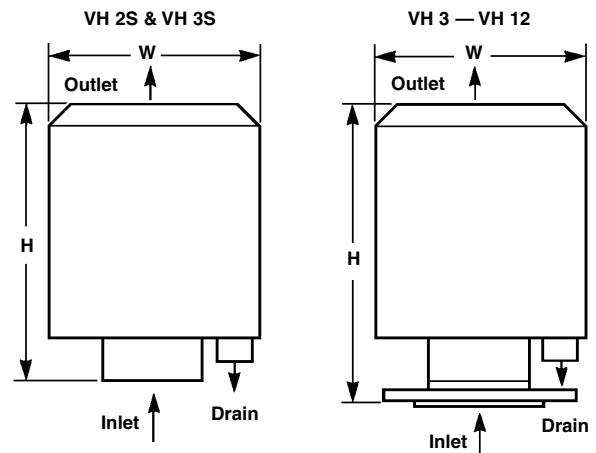

**Inlet Connections:** VH 2S is screwed 2" NPT; VH3S is screwed 3" NPT  
VH 3 — VH 12 flanged to suit ANSI 150  
Flanges are the lap joint type.

Local regulation may restrict the use of this product below the conditions quoted. Limiting conditions refer to standard connections only.

In the interests of development and improvement of the product, we reserve the right to change the specification.

TI-10-5310-US 11.95