

# spirax sarco®

## TW 3 Port Valve for Liquid Systems

The TW is a 3-way self actuated temperature control valve which may be used on liquid systems as either a diversion valve for heating or cooling, or a mixing valve for blending hot and cold water.

<b>Model</b> ⇄	TW
<b>Sizes</b>	3/4", 1", 1-1/2"
<b>Connections</b>	NPT
<b>Construction</b>	Bronze

### LIMITING OPERATING CONDITIONS

#### Maximum Differential Pressure

3/4" to 1-1/2"    50 psi    3.4 bar

### OPERATING RANGE

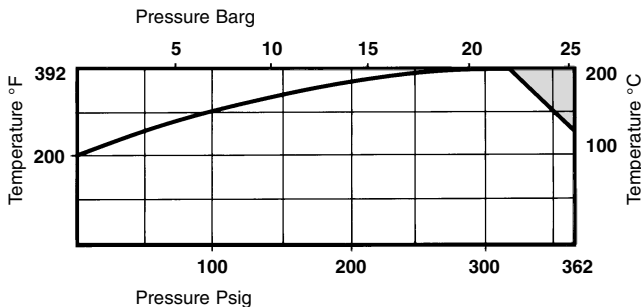

 The valves must not be used in this region

 The valves may be used in this region provided that the above maximum differential pressures are not exceeded. Valves with ANSI flanges must not be used above flange limits.

SHUTOFF: ANSI CLASS III

### PRESSURE SHELL DESIGN CONDITIONS

**PMA**                      362 psig/0-248°F    25 barg/120°C  
Max. allowable pressure    319 psig/0-392°F    22 barg/0-200°C

**TMA**                      392°F/0-319 psig    200°C/0-22 barg  
Max. allowable temperature

### TYPICAL APPLICATIONS

Industrial or commercial applications using water as a heating or cooling medium.

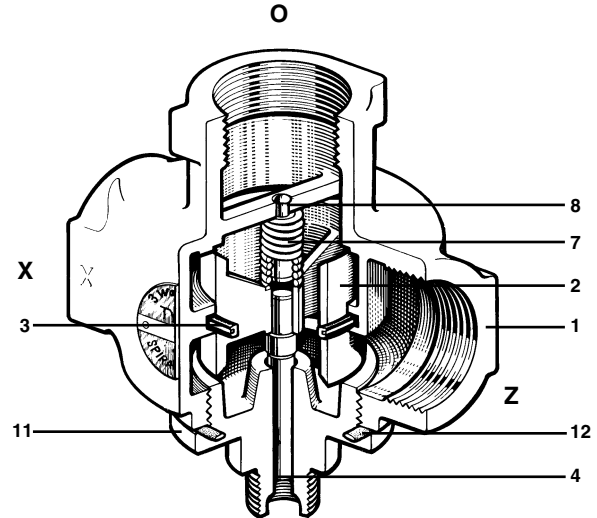

### CONSTRUCTION MATERIALS

No.	Part	Material	Material Spec.	Closest Equivalent
1	Body	Bronze	BS 1400 LG2	B62 UNS 83600
2	Piston	Bronze	BS 1400 LG2	B62 UNS 83600
3	Piston Sealing Ring	Carbon Impregnated PTFE		
4	Stem	Brass	BS 2874 CZ 121	B16M
7	Return Spring	Stainless Steel	BS 2056 302 S26	A313 Type 302
8	Return Spring Plate	Brass	BS 2874 CZ 121	B16M
11	Bonnet	Brass	BS 2874 CZ 121	B16M
12	Bonnet Gasket	Nickle Reinforced Exfoliated Graphite		

Local regulation may restrict the use of this product below the conditions quoted. Limiting conditions refer to standard connections only.

In the interests of development and improvement of the product, we reserve the right to change the specification.

TI-1-809-US 08.99

# TW 3 Port Valve for Liquid Systems

## DIMENSIONS (NOMINAL) IN INCHES AND MILLIMETERS

SCREWED				
SIZE	A	C	D	WEIGHT
3/4"	3.8 97	2.3 58	2.1 54	2.7 lb 1.2 kg
1"	4.5 114	2.4 61	2.2 57	4.3 lb 1.9 kg
1-1/2"	5.9 151	3.0 76	2.8 70	8.5 lb 3.8 kg

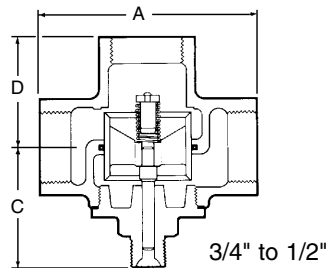

## SAMPLE SPECIFICATION

Control valve shall be bronze body, bronze trim, piston balanced 3 port with screwed connections. Valve shall achieve ANSI Class III Shutoff. Valve is coupled to the appropriate temperature control system. This combined unit is self acting and provides proportional control action. The temperature control system shall be brass with PVC covered capillary or stainless steel sensor and capillary, oil filled, hydraulically operated; and shall incorporate packless glands and a gas filled overheat protection device. Temperature setting shall be adjustable while control is in service include, °F adjustment scale and shall incorporate a tamper proof device. When required, sensor bulb shall be mounted in a separable well for removal from the equipment. Refer to TIS 1.900 or 1.901 for temperature control system details.

## PIPING ARRANGEMENTS

Application	Port 'O'	Port 'X'	Port 'Z'
Diversion Valve - Heating	Flow in	to heating surface	to recirculation
Diversion Valve - Cooling	Flow in	to recirculation	to cooling surface
Mixing Valve	Blended Outlet	Hot flow in	Cold flow in

Note: Port 'X' closes on high temperature; port 'Z' closes on low temperature; Port 'O' is always open

## C<sub>v</sub> VALUES

3/4"	1"	1-1/2"
5.4	10.5	24

For complete sizing information, see TIS 1.012 .

## INSTALLATION

The valve should be installed in a horizontal section of pipe with the control system connection pointing vertically downward. Suitable stop valves should be provided to permit servicing, and Y-pattern strainers should be installed in the inlet piping. The valve ports are marked 'O', 'X' and 'Z', and piping instructions are supplied with each valve.

## MAINTENANCE

Except for periodic cleaning of the upstream strainer, maintenance or servicing is normally required only is a malfunction is detected.

**Complete installation and maintenance instructions are given in the IMI sheet, which accompanies the product.**

## SPARE PARTS

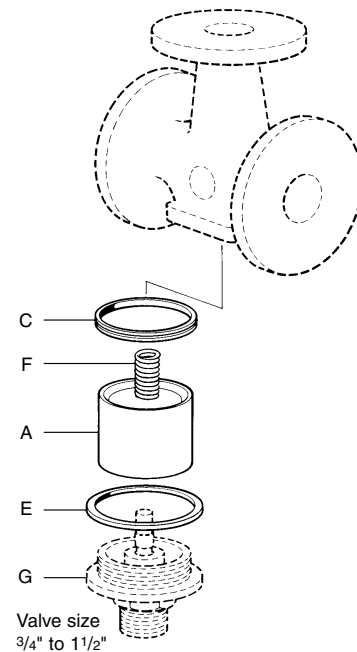

Piston Sealing Ring	C, F, E
Piston Set	A, C, E, F
Set of Cover Studs & Nuts	P

Available spare parts are shown in heavy outline. Parts drawn in broken line are not supplied as spares.