

spirax sarco®

NS and NSRA Bronze Self-Acting Control Valves

NS
Normally open, closes with temperature rise for heating, double seat.

NSRA
Normally closed, opens with rising temperature for cooling, double seat.

Model	NS, NSRA
Sizes	2½", 3"
Connections	NPT
Construction	Bronze Body and Trim
Options	BSP Connections ANSI 150 or 300 flanges

NOTE: NS & NSRA are not to be used with HL10/130 safeguard overheat protection.

Limiting Operating Conditions

Maximum Differential Pressure

Size/DN	NS	NSRA
2½"	150 psi*	40 psi
65	10 bar	2.7bar
3"	150 psi*	30 psi
80	10 bar	2 bar

*On liquid applications, the permissible maximum differential pressure may be affected by high static pressure. Please consult the factory if the application requires a large differential pressure with a high inlet pressure. Not to be used in compressed air applications.

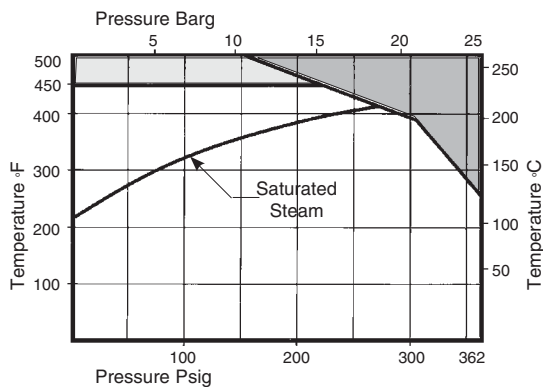

If the valve is to be used in this region, a spacer (stock #0467000) must be fitted between the valve and the control system to protect the control system from overheating.

The valves must not be used in this region

The valves may be used in this region provided that the above maximum differential pressures are not exceeded. Valves with ANSI flanges must not be used above flange limits.

SHUTOFF: ANSI CLASS II

Pressure Shell Design Conditions

PMA
Max. allowable pressure
362 psig/248°F 25 barg/120°C
253 psig/428°F 17.5 barg/220°C
152 psig/500°F 10.5 barg/260°C

TMA
Max. allowable temperature
500°F/0-152 psig 260°C/0-10.5 barg

NS Valve

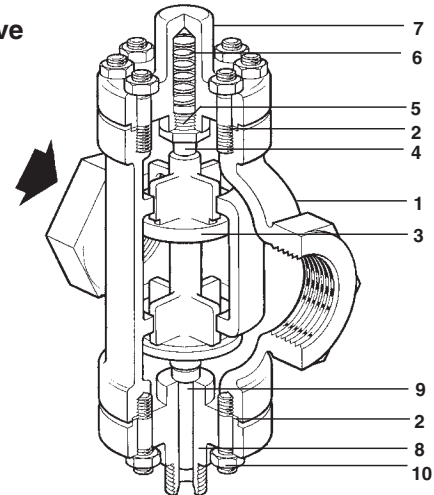

NSRA Valve

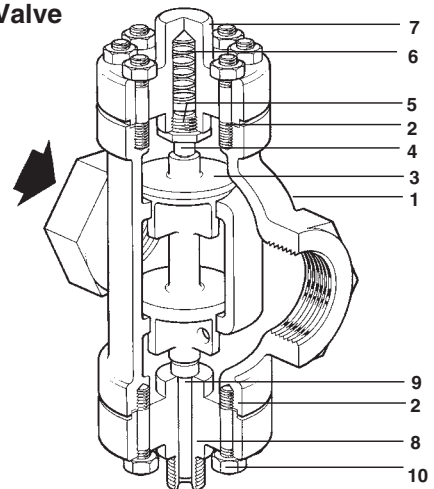

Construction Materials

No.	Part	Material	Material Spec.
1	Body	Gun-metal	BS 1400 LG2
2	Body Gasket	Semi-ridged graphite	BS 2815 Gr A
3	Valve Closure Member	Gun-metal	BS 1400 LG 2
4	Plunger	Brass	BS 2874 CZ 121
5	Plunger Guide	Brass	BS 2874 CZ 121
6	Return Spring	Stainless Steel	BS 2056 302 S 26
7	Spring Housing	Gun-metal	BS 1400 LG 2
8	Bonnet	Gun-metal	BS 1400 LG 2
9	Stem	Brass	BS 2874 CZ 121
10	Body Studs	Steel	BS 4439 Gr 8.8
	Body Nuts	Steel	BS 3692 Gr 8
	2½"	M12	
	3½"	M16	

Local regulation may restrict the use of this product below the conditions quoted. Limiting conditions refer to standard connections only.
In the interests of development and improvement of the product, we reserve the right to change the specification.

TI-1-802-US 5.09

NS and NSRA Bronze Self-Acting Control Valves

Dimensions (nominal) in inches and millimeters

Size DN	ANSI 300/150			Weight	
	A	B	C	NPT	Fig.
2½" 65	6.7 171	8.0 203	5.9 150	18.0 lb 8.1 kg	38.0 lb 17.2 kg
3" 80	7.6 194	9.2 236	6.3 160	30.0 lb 13.6 kg	50.0 lb 22.7 kg

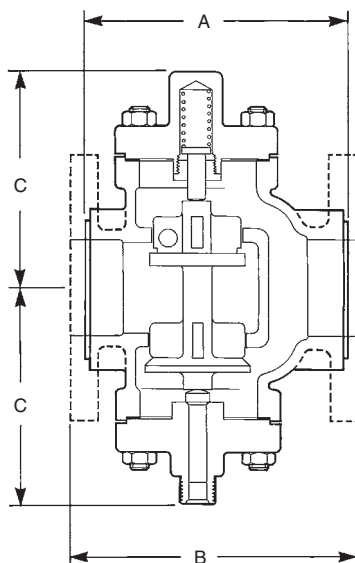

C_v at P Band*

Size	2½"	3
C _v	75.6	109.2
P Band (°F)*	24°	24°

*The proportional band (P Band) is the difference required between the desired set temperature and the actual controlled temperature to open the valve fully. The above figures apply to valves fitted with 121 or 123 control systems.

For complete sizing information, see TIS 1.011 (steam) or TIS 1.012 (water).

Typical Applications

Industrial or commercial applications using steam or hot water as a heating medium, or water for cooling.

Spare Parts

Body Gasket (pkt of 6) See item #2 in Construction Materials

Sample Specification

Control valve shall be bronze body with bronze trim. Valve shall achieve ANSI Class II Shutoff. Valve is coupled to the appropriate temperature control system. This combined unit is self acting and provides proportional control action. The temperature control system shall be brass with PVC covered capillary or stainless steel sensor and capillary, oil filled, hydraulically operated; and shall incorporate packless glands and a gas filled overheat protection device. Temperature setting shall be adjustable while control is in service, include °F adjustment scale and shall incorporate a tamper proof device. When required, sensor bulb shall be mounted in a separable well for removal from the equipment. Refer to TI-1-900-US or TI-1-901-US for temperature control system details.

Installation

The valve should be installed in a horizontal section of the heating or cooling medium inlet piping. The control system connection must point vertically downward. A bypass with suitable stop valves should be provided to permit servicing, and a Y-pattern strainer should be installed upstream of the valve. If the valve is smaller than the pipeline, eccentric reducers should be used. In a steam system, a steam trap should be installed upstream of the valve to ensure that the steam entering the valve is as dry as possible.

Maintenance

Except for periodic cleaning of the upstream strainer, maintenance or servicing is normally required only if a malfunction is detected. Complete installation and maintenance instructions are given in the IMI sheet (IM-S21-01), which accompanies the product.

TI-1-802-US 5.09