

spirax/sarco®

SB and SBRA Bronze Valves

SB

Normally open, closes with temperature rise for heating, single seat.

SBRA

Normally closed, opens with rising temperature for cooling. Single seat with optional 1/8" (C_v .44) bleed bypass and optional fusible device.

Model ↔	SB, SBRA
Sizes	1/2", 3/4", 1"
Connections	NPT
Construction	Bronze Body Stainless Steel Trim
Options	BSP Connections ANSI 300 flanges (SB only)

Limiting Operating Conditions

Maximum Differential Pressure

Size/DN	SB	SBRA
1/2	250 psi* 17 bar	174 psi 12 bar
3/4	150 psi* 10 bar	101 psi 7 bar
1	100 psi* 6.8 bar	70 psi 4.7 bar

* On liquid applications, the permissible maximum differential pressure may be affected by high static pressure. Please consult the factory if the application requires a large differential pressure with a high inlet pressure.

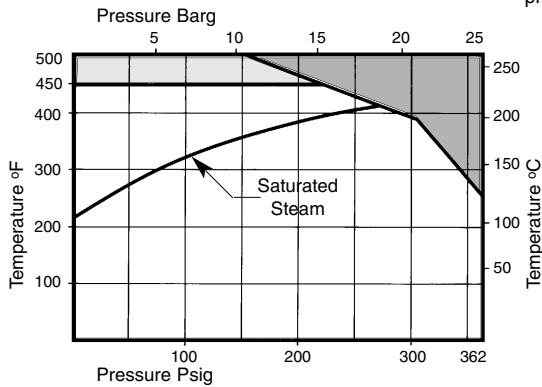

If the valve is to be used in this region, a spacer (stock #0467000) must be fitted between the valve and the control system to protect the control system from overheating.

The valves must not be used in this region

The valves may be used in this region provided that the above maximum differential pressures are not exceeded. Valves with ANSI flanges must not be used above flange limits.

SHUTOFF: ANSI CLASS IV

Pressure Shell Design Conditions

PMA	362 psig/248°F	25 barg/120°C
Max. allowable pressure	253 psig/428°F	17.5 barg/220°C
	152 psig/500°F	10.5 barg/260°C

TMA	500°F/0-152 psig	260°C/0-10.5 barg
Max. allowable temperature		

Typical Applications

Industrial or commercial applications using steam or hot water as a heating medium, or water for cooling.

Local regulation may restrict the use of this product below the conditions quoted. Limiting conditions refer to standard connections only.

In the interests of development and improvement of the product, we reserve the right to change the specification.

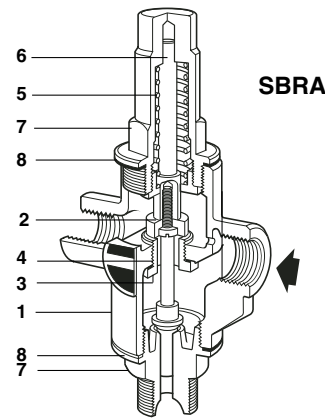
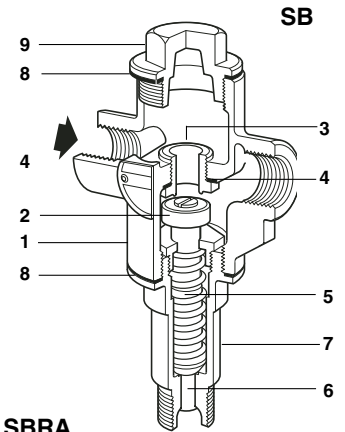

SBRA with fusible device and bleed

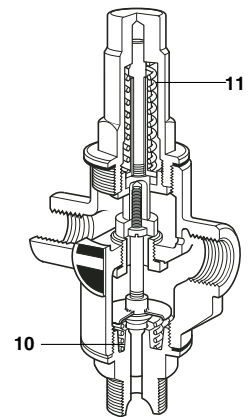

Construction Materials

No.	Part	Material	Material Spec.	Closest Equivalent
1	Body	Bronze	BS 1400 LG2	B62 UNS 83600
2	Valve	Stainless Steel	BS 970 431 S29	A276 Type 431
3	Valve Seat	Stainless Steel	BS 970 431 S29	A276 Type 431
4	Valve Seat Gasket	Copper	BS 2870 C102	B152 UNS C10200
5	Return Spring	Stainless Steel		
6	Push Rod	Brass	BS 2874 CZ 121	B16M
7	Bonnet	Brass	BS 2874 CZ 121	B283 UNS No. 37700
8	Bonnet Cap Gasket	Nickle Reinforced Exfoliated Graphite		
9	Cap	Brass	BS 2872 CZ 122	B283 UNS No. 37700
10	Fail Safe Spring	Stainless Steel	BS 2056 302 S26	
11	Fusible Devise	Brass	BS 2874 CZ 121	

SB and SBRA Bronze Valves

Dimensions (nominal) in inches and millimeters

SB VALVES SIZE DN	ANSI 300				WEIGHT	
	A	B	C	D	Scr.	Flg.
1/2 15	3.1 79	3.9 98	3.9 101	2.0 50	2.3 lb 1.0 kg	7.7 lb 3.5 kg
3/4 20	3.7 95	4.4 113	3.9 101	2.0 50	3.0 lb 1.3 kg	8.0 lb 3.6 kg
1 25	4.7 108	5.0 128	3.9 101	2.0 50	3.5 lb 1.5 kg	8.5 lb 3.8 kg
SBRA						
1/2 15	3.1 79	-	2.6 66	3.7 95	2.3 lb 1.0 kg	-
3/4 20	3.7 95	-	2.6 66	3.7 95	3.0 lb 1.3 kg	-
1 25	4.7 108	-	2.6 66	3.7 95	3.5 lb 1.5 kg	-

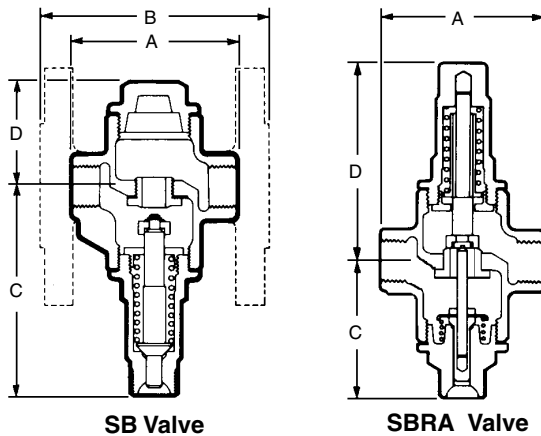

Cv at P Band*

Size	1/2"	3/4"	1"
Cv	3.0	4.5	7.9
P Band (°F)*	8°	8°	10°

* The proportional band (P Band) is the difference required between the desired set temperature and the actual controlled temperature to open the valve fully. The above figures apply to valves fitted with 121 or 123 control systems. For 122 or 128 systems, the P Band will be twice the amount shown.

Example: For a 3/4" SB valve with a 122 control system, the valve will not fully open until the controlled temperature drops to 16° F below the set point. For complete sizing information, see TIS 1.011 (steam) or TIS 1.012 (water).

Sample Specification

Control valve shall be bronze body with stainless steel trim. Valve will achieve ANSI Class IV Shutoff. Valve is coupled to the appropriate temperature control system. This combined unit is self acting and provides proportional control action. The temperature control system shall be brass with PVC covered capillary or stainless steel sensor and capillary, oil filled, hydraulically operated; and shall incorporate packless glands and a gas filled overheat protection device. Temperature setting shall be adjustable while control is in service, include °F adjustment scale and shall incorporate a tamper proof device. When required, sensor bulb shall be mounted in a separable well for removal from the equipment. Refer to TIS 1.900 or 1.901 for temperature control system details.

Installation

The valve should be installed in a horizontal section of the heating or cooling medium inlet piping. The control system connection must point vertically downward. A bypass with suitable stop valves should be provided to permit servicing, and a Y-pattern strainer should be installed upstream of the valve. If the valve is smaller than the pipeline, eccentric reducers should be used. In a steam system, a steam trap should be installed upstream of the valve to ensure that the steam entering the valve is as dry as possible.

Spirax Sarco, Inc., 1150 Northpoint Blvd, Blythewood, SC 29016

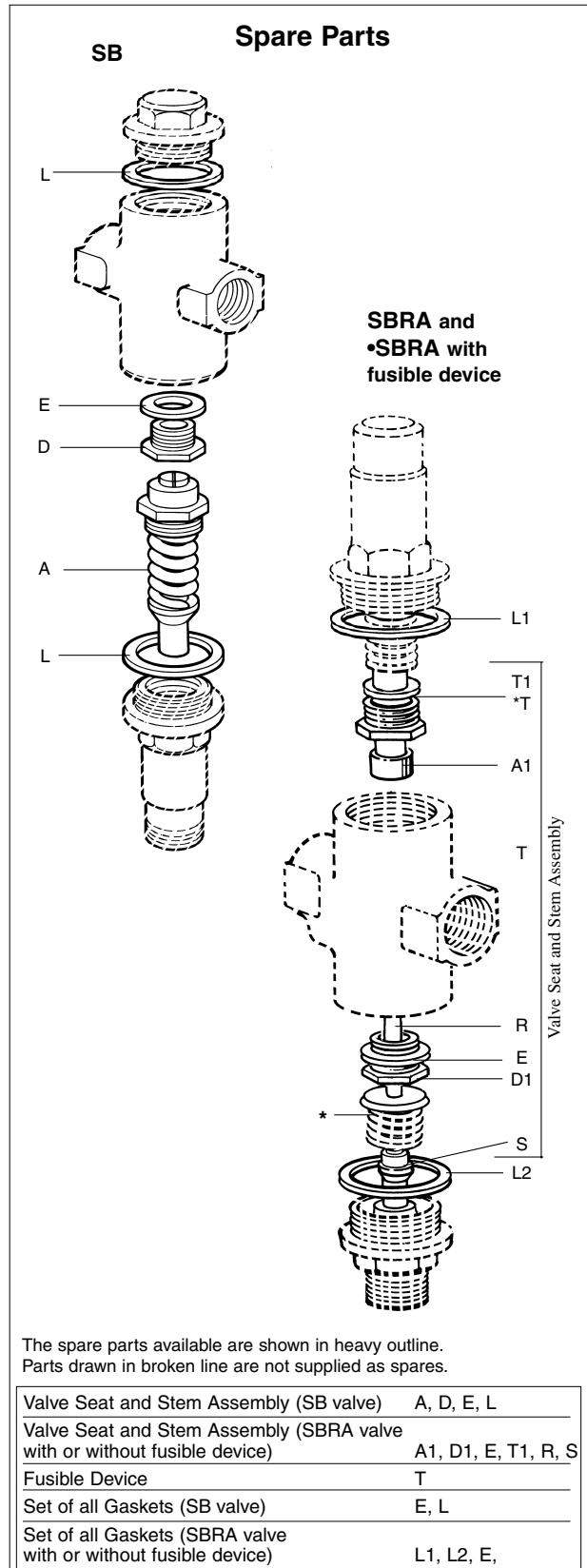

The spare parts available are shown in heavy outline. Parts drawn in broken line are not supplied as spares.

Maintenance

Except for periodic cleaning of the upstream strainer, maintenance or servicing is normally required only if a malfunction is detected. **Complete installation and maintenance instructions are given in the IMI sheet, which accompanies the product.**

TI-1-801-US 09.03

Telephone: (803) 714-2000 FAX (803) 714-2222