

spirax/sarco®

K Series 1/2" to 4" Stainless Steel Control Valves

Description

A range of two port stainless steel single seat globe valves conforming to ANSI/ASTM standards in sizes 1/2" to 4" (DN15 to DN100) available with screwed or flanged connections. When used in conjunction with a pneumatic or electric linear actuator, they provide characterized modulating or on/off flow control. For close control with pneumatic actuators, a valve positioner should be used.

Sizes and pipe connections

KEA61 1/2", 3/4", 1", 1-1/4", 1-1/2" and 2" screwed NPT.
KEA63 1/2", 3/4", 1", 1-1/2", 2", 2-1/2", 3" and 4" flanged ANSI 150 and ANSI 300

Options

Trim	Equal %, linear, reduced C _v , fast opening (on/off) soft seal, hard faced, low noise, and anti-cavitation.
Stem seal	PTFE chevrons or graphite packing.

Refer to TI-P305-04 US for further details.

Technical data

Plug design	1/2" to 1-1/4" (DN15 to DN32)	Caged parabolic
	1-1/2" to 4" (DN40 to DN100)	Vee port
Leakage	Metal-to-metal seat	ANSI/FCI 70/2 Class IV
	PTFE soft seal	ANSI/FCI 70/2 Class VI
Flow characteristic	KEA valves	Equal percentage (modulating)
	KLA valves	Linear (modulating)
	KFA valves	Fast opening (on/off)
Rangeability		50 to 1
Travel	1/2" to 2" (DN15 to DN50)	3/4" (20 mm)
	2-1/2" to 4" (DN15 to DN50)	1-3/16" (30 mm)

Limiting conditions

Body design conditions	ANSI 150 and ANSI 300	
Maximum design temperature	PTFE chevron seals	482°F (250°C)
	Graphite packed seals	800°F (426°C)
Minimum design temperature	-148°F (-100°C)	
Maximum cold hydraulic test pressure	ANSI 150	425 psig (29.3 bar g)
	ANSI 300	1100 psig (75.8 bar g)
Maximum differential pressures	see actuator TIS	

Operating range

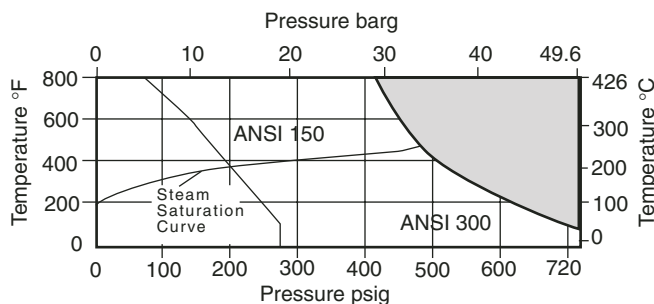

K_A63 1/2" to 1-3/4"

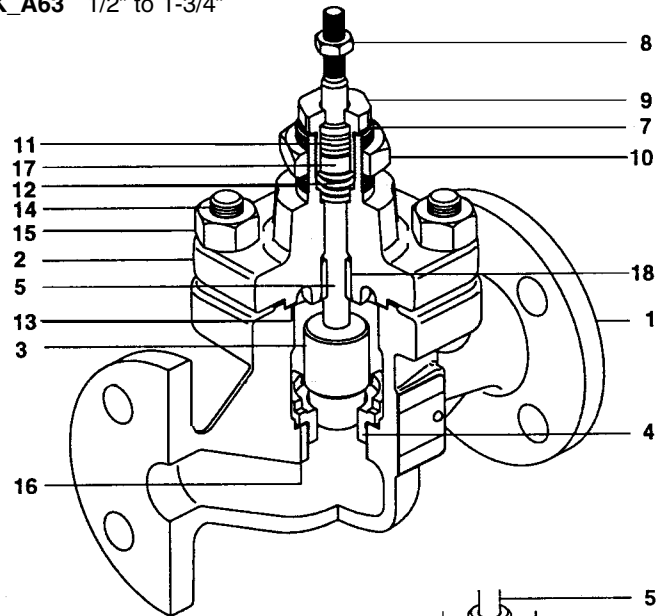

K_A
1-1/2" to 4" plug and seat

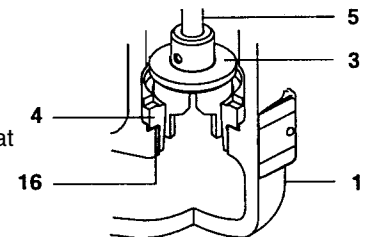

Materials

1	Body	Stainless steel	ASTM A351 CF8M
2	Bonnet	Stainless steel	ASTM A351 CF8M
3	Valve plug	Stainless steel	ASTM A276 316L
4	Valve seat	Stainless steel	ASTM A276 316L
5	Valve stem	Stainless steel	ASTM A276 316L
7	Gland nut gasket	Semi-rigid graphite laminated	
8	Lock-nut	Stainless steel	
9	Gland nut	Stainless steel	ASTM A276 31 6L
10	Mounting nut	Mild steel zinc plated	
11	Gland seals	PTFE chevrons	
12	Gland spring	Stainless steel	
13	Bonnet gasket	Semi-rigid graphite laminated	
14	Bonnet studs	Stainless steel	ASTM A193 B8 M2
15	Bonnet nuts	Stainless steel	ASTM A194 8M
		1/2" to 3/4" (DN15 and DN20)	3/8" UNC
		1" to 2" (DN25 to DN50)	1/2" UNC
		2-1/2" to 4" (DN65 to DN100)	5/8" UNC
16	Seat gasket	Semi-rigid graphite laminated	
17	Guide bush	Glass reinforced PTFE	
18	Bonnet guide	Stainless steel	
		Stellite	

Note: Part No.18 'Bonnet guide' used on all valves above 1-1/2" and valves having soft seat and hard faced trims in smaller sizes.

Local regulation may restrict the use of this product below the conditions quoted. Limiting conditions refer to standard connections only.
In the interests of development and improvement of the product, we reserve the right to change the specification.

TI-1-427-US 09.03

K Series

1/2" to 4" Stainless Steel Control Valves

C_V Values

Size	1/2" (DN15)	3/4" (DN20)	1" (DN25)	1-1/4" (DN32)	1-1/2" (DN40)	2" (DN50)	2-1/2" (DN65)	3" (DN80)	4" (DN100)
Equal % and linear trim	4.7	7.4	11.7	18.7	29.3	42	74	117	187
On/Off trim	4.7	7.4	11.7	21.0	32.8	59	99	137	211

Three reductions in C_V are available for equal percentage and linear trims, for further details see TIS 1.427.
 For conversion C_V(UK) = C_V(US) x 0.833 K_{VS} = C_V(US) x 0.855

Dimensions

(approximate) in inches (mm)

Valve size	A	B (ANSI 150)	B (ANSI 300)	C	D
1,2" (DN15)	6.5 (165)	7.3 (184)	7.5 (191)	3.3 (84)	1.69 (43)
3/4" (DN20)	6.5 (165)	7.3 (184)	7.6 (194)	3.4 (87)	1.7 (44)
1" (DN25)	7.8 (197)	7.3 (184)	7.8 (197)	3.8 (96)	2.0 (51)
1-1/4" (DN32)	8.5 (216)	-	-	4.0 (101)	2.3 (58)
1-1/2" (DN40)	9.3 (235)	8.8 (222)	9.3 (235)	4.0 (101)	2.5 (64)
2" (DN50)	10.5 (267)	10.0 (254)	10.5 (267)	4.2 (106)	3.0 (76)
2-1/2" (DN65)	-	10.9 (276)	11.5 (292)	5.4 (136)	-
3" (DN80)	-	11.8 (298)	12.5 (318)	5.6 (141)	-
4" (DN100)	-	13.9 (353)	14.5 (368)	6.5 (165)	-

Weights

(approximate) in pounds (kg)

	K A61	K A63
1,2"	8.4 (3.8)	10.6 (4.8)
3/4"	8.8 (4.0)	13.2 (6.0)
1"	12.1 (5.5)	18.1 (8.2)
1-1/4"	17.6 (8.0)	-
1-1/2"	19.9 (9.0)	30.9 (14.0)
2"	23.2 (10.5)	36.4 (16.5)
2-1/2"	-	59.5 (27.0)
3"	-	72.8 (33.0)
4"	-	103.6 (47.0)

Sizing

For steam see TIS 1.618.

Installation

The valve should be installed in a horizontal pipeline with the direction of flow arrow as indicated by the arrow on the valve body. If necessary the actuator should be commissioned in accordance with the Installation and Maintenance Instructions supplied with the valve.

How to order

Example: 1 off - 2" KEA63 C_V (US) 42 control valve flanged ANSI 300.

Spare parts

See TIS 1.430.

Compatible actuators and positioners

Electric	EL3500, EL5060 and EL5600 series.
Pneumatic	PN5000, 6000, 3000, 4000, 1000 Series.
Positioners	PP5 (pneumatic), EPS (electropneumatic) and SP2 (smart electropneumatic).

Refer to relevant TIS sheet for further details

KEA61 1/2" to 2"

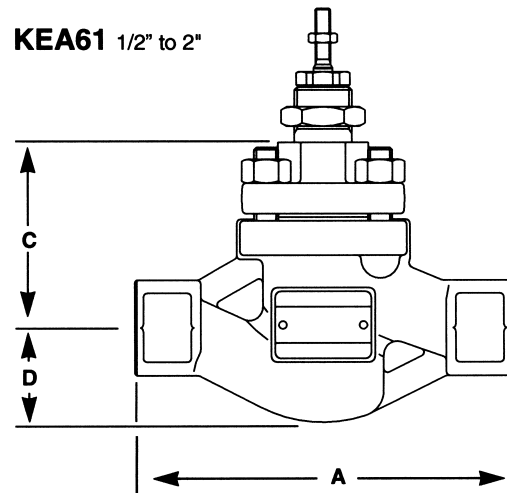

KEA63 1/2" to 4"

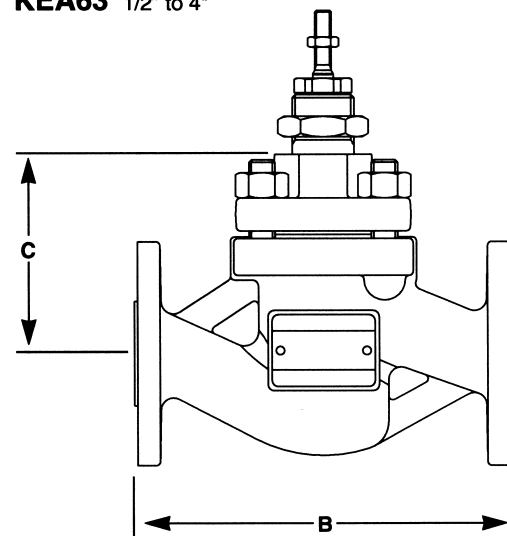

TI-1-427-US 09.03