

spirax sarco®

Direct Acting Temperature Regulator 25 MT

The 25 MT is a self-actuated temperature control valve with a calibrated dial for accurate temperature setting. A variety of solid-fill sensing bulbs are available (see TI-1-1123-US). The standard capillary tubing length is 8 feet, with an optional standard length of 15 feet.

Model	25MT
Sizes	½"
Connections	NPT
Construction	Cast Iron
Options	BSP Connections Non-standard capillary tubing lengths (see TI-1-1123-US)

Construction Materials

No.	Part	Material	
1	"M" Body	Cast Iron	ASTM A 126 CL B
2	Gasket	Graphite	
19	"T" Body	Cast Iron	ASTM A 126 CL B
30	Pilot Valve Seat	Stainless Steel	AISI 303
31	Pilot Valve Head	Stainless Steel	AISI 440A
32	Adjustment Knob	Phenolic	ASTM D 700 Ty 2
33	Pointer	Stainless Steel	AISI 301
34	Extension Nut	Brass	ASTM B 16
35	Case Tube	Brass	ASTM B 135 (330)
36	Retaining Nut	Brass	ASTM B 16
37	Pilot Mounting Screws	Steel	ASTM A449
38	Capillary Tube	Varies with style selected	
39	Bulb	Varies with style selected	

Typical Applications

Small storage steam water heaters, instantaneous heat exchangers and converters, air handling coils, tank heating coils, steam jacketed vessels, steam chests, molds and platens.

Sample Specification

The temperature control valves shall be self-actuated. The temperature setting shall be adjustable without the use of tools, and the set point shall be indicated on a calibrated dial. Thermostatic system shall be solid fill, and shall incorporate overheat protection.

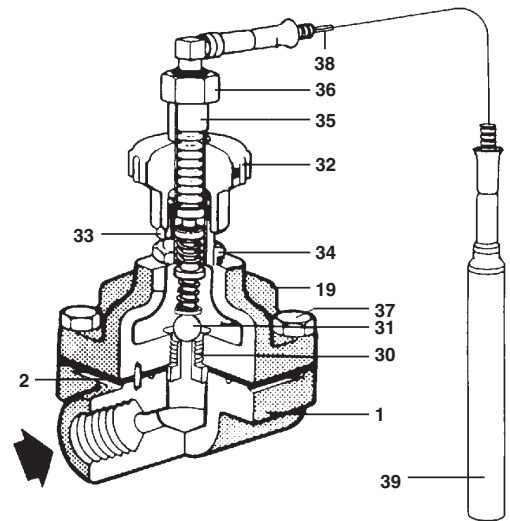

25 MT Capacity Pounds of Saturated Steam per Hour

Inlet Press Psig	Outlet Press Psig	Capacity (Lb/Hr) Vs P-Band (°F)		
		Cv > .134	5	10
10	0	5.3	9.7	18.5
10	3	4.8	8.8	16.6
10	5	4.3	7.8	14.8
25	0-5	8.5	15.6	29.7
25	15	7.4	13.6	25.8
25	20	5.6	10.4	19.7
50	0-18	13.9	25.5	48.3
50	35	11.7	21.5	40.8
50	42	9.1	16.8	31.8
75	0-30	19.2	35.3	67.0
75	55	16.0	29.4	55.8
75	65	12.1	22.2	42.2
100	0-43	24.6	45.1	85.7
100	75	20.3	37.3	70.7
100	85	16.6	30.4	57.8
150	0-68	35.3	64.8	123.1
150	105	31.5	57.8	109.7
150	130	23.1	42.3	80.4
200	0-93	46.0	84.5	160.4
200	140	41.3	75.8	144.0
200	170	31.9	58.6	111.2
250	0-118	56.8	104.2	197.8
250	175	51.1	93.9	178.3
250	210	40.7	74.6	141.7

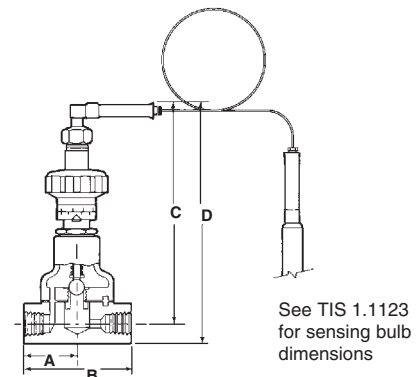

Dimensions (nominal) in inches and millimeters

Size	A	B	C	D	Weight
½"	1.75	3.5	7.38	8.06	5.25 lb
	44	89	187	205	2.4 kg

Local regulation may restrict the use of this product below the conditions quoted. Limiting conditions refer to standard connections only.
In the interests of development and improvement of the product, we reserve the right to change the specification.

TI-1-1125-US 05.09

Direct Acting Temperature Regulator 25 MT

Limiting Operating Conditions

Max. Operating Pressure (PMO) 250 psig (17 barg)

Max. Operating Temperature* 450°F (232°C)

*The temperature of the sensing bulb must not exceed 350°F (177°C)

Standard Temperature Ranges

30°F to 90°F	0°C to 32°C		
60°F to 120°F	15°C to 50°C	160°F to 220°F	70°C to 105°C
100°F to 160°F	40°C to 70°C	200°F to 260°F	95°C to 125°C
120°F to 180°F	50°C to 80°C	260°F to 320°F	125°C to 160°C

Pressure Shell Design Conditions

PMA 250 psig/0-450°F 17 barg/0-232°C
Max. allowable pressure

TMA 450°F/0-250 psig 232°C/0-17 barg
Max. allowable temperature

Installation and Maintenance

The regulator should be installed in a horizontal pipe with suitable by-pass and isolating valves. A steam trap must be installed upstream to prevent condensate from reaching the regulator. The trap and regulator should both be protected with a strainer. The thermostatic bulb must be carefully located in the medium being heated. Complete installation & maintenance instruction are given in IM-1-1125-US, which accompanies the product.

Spare Parts

Temperature Pilot
(see TIS 1.1123)

Thermal System (T1, T2, T3, T10, T11, T12) State bulb style, capillary tube length and temperature range	A2
Well (T5, T6, T7, T8) (Specify bulb style)	B2
Wall Mounting Bracket (T9) (State bulb size)	C2
Complete Pilot Adjustment Assembly	D2, W
Head & Seat Assembly (Specify 15 psig or below Assembly or Standard)	E2, W

© Spirax Sarco, Inc. 2009

TI-1-1125-US 05.09