

SSC20

Sanitary Sample Cooler



1. Safety information
2. General product information
3. Installation
4. Commissioning
5. Operation
6. Maintenance
7. Spare parts

1. Safety information

Safe operation of these products can only be guaranteed if they are properly installed, commissioned, used and maintained by qualified personnel (see Section 1.11) in compliance with the operating instructions. General installation and safety instructions for pipeline and plant construction, as well as the proper use of tools and safety equipment must also be compiled with.

1.1 Intended use

Referring to the Installation and Maintenance Instructions, name-plate and Technical Information Sheet, check that the product is suitable for the intended use/application. The products comply with the requirements of the European Pressure Equipment Directive 97/23/EC and fall within category 'SEP'. It should be noted that products within this category are required by the directive not to carry the mark.

- i) The products have been specifically designed for use on steam and water, which are in Group 2 of the above mentioned Pressure Equipment Directive. The products' use on other fluids may be possible but, if this is contemplated, Spirax Sarco should be contacted to confirm the suitability of the product for the application being considered.

- ii) Check material suitability, pressure and temperature and their maximum and minimum values. If the maximum operating limits of the product are lower than those of the system in which it is being fitted, or if malfunction of the product could result in a dangerous overpressure or overtemperature occurrence, ensure a safety device is included in the system to prevent such over-limit situations.
- iii) Determine the correct installation situation and direction of fluid flow.
- iv) Spirax Sarco products are not intended to withstand external stresses that may be induced by any system to which they are fitted. It is the responsibility of the installer to consider these stresses and take adequate precautions to minimize them.
- v) Remove protection covers from all connections before installation.

1.2 Access

Ensure safe access and if necessary a safe working platform (suitably guarded) before attempting to work on the product. Arrange suitable lifting gear if required.

1.3 Lighting

Ensure adequate lighting, particularly where detailed or intricate work is required.

1.4 Hazardous liquids or gases in the pipeline

Consider what is in the pipeline or what may have been in the pipeline at some previous time. Consider: flammable materials, substances hazardous to health, extremes of temperature.

1.5 Hazardous environment around the product

Consider: explosion risk areas, lack of oxygen (e.g. tanks, pits), dangerous gases, extremes of temperature, hot surfaces, fire hazard (e.g. during welding), excessive noise, moving machinery.

1.6 The system

Consider the effect on the complete system of the work proposed. Will any proposed action (e.g. closing isolation valves, electrical isolation) put any other part of the system or any personnel at risk?

Dangers might include isolation of vents or protective devices or the rendering ineffective of controls or alarms. Ensure isolation valves are turned on and off in a gradual way to avoid system shocks.

1.7 Pressure systems

Ensure that any pressure is isolated and safely vented to atmospheric pressure. Consider double isolation (double block and bleed) and the locking or labeling of closed valves. Do not assume that the system has depressurized even when the pressure gauge indicates zero.

1.8 Temperature

To avoid burns, it is essential that cooling water is flowing before opening the sample inlet valve. Always close the sample inlet valve before turning off the cooling water.

1.9 Tools and consumables

Before starting work ensure that you have suitable tools and/or consumables available. Use only genuine Spirax Sarco replacement parts.

1.10 Protective clothing

Consider whether you and/or others in the vicinity require any protective clothing to protect against the hazards of, for example, chemicals, high/low temperature, radiation, noise, falling objects, and dangers to eyes and face.

1.11 Permits to work

All work must be carried out or be supervised by a suitably competent person.

Installation and operating personnel should be trained in the correct use of the product according to the Installation and Maintenance Instructions.

Where a formal 'permit to work' system is in force it must be complied with. Where there is no such system, it is recommended that a responsible person should know what work is going on and, where necessary, arrange to have an assistant whose primary responsibility is safety. Post 'warning notices' if necessary.

1.12 Handling

Manual handling of large and/or heavy products may present a risk of injury. Lifting, pushing, pulling, carrying or supporting a load by bodily force can cause injury particularly to the back. You are advised to assess the risks taking into account the task, the individual, the load and the working environment and use the appropriate handling method depending on the circumstances of the work being done.

1.13 Residual hazards

In normal use the external surface of the product may be very hot. If used at the maximum permitted operating conditions the surface temperature of some products may reach temperatures of 662°F (350°C). Many products are not self-draining. Take due care when dismantling or removing the product from an installation (refer to 'Maintenance instructions').

1.14 Freezing

Provision must be made to protect products which are not self-draining against frost damage in environments where they may be exposed to temperatures below freezing point.

1.15 Disposal

Unless otherwise stated in the Installation and Maintenance Instructions, this product is recyclable and no ecological hazard is anticipated with its disposal providing due care is taken.

1.16 Returning products

Customers and stockists are reminded that under EC Health, Safety and Environment Law, when returning products to Spirax Sarco they must provide information on any hazards and the precautions to be taken due to contamination residues or mechanical damage which may present a health, safety or environmental risk. This information must be provided in writing including Health and Safety data sheets relating to any substances identified as hazardous or potentially hazardous.

2. General product information

2.1 Description

The Spirax Sarco SSC20 sanitary sample cooler has been specifically designed for taking high quality chemical, conductivity and microbiological samples quickly and safely from clean/pure steam, water for injection (WFI) and other high purity media systems.

The unit consists of high quality 316L stainless steel components and utilizes a counter current flow to maximize cooler efficiency, resulting in a compact, space saving design.

All sample contact surfaces are compliant to current ASME BPE. Surface finish of better than 0.5 µ-m Ra (20 µ-in Ra).

The unit is provided with an integral pre drilled mounting bracket to allow simple installation at point of use.

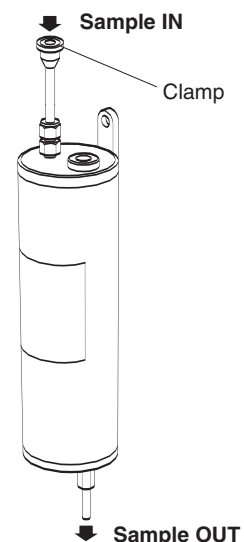

2.2 Sizes and pipe connections

Cooling water inlet and outlet connections	BSP version	1/2" BSP
	NPT version	1/2" NPT
Sample tube inlet and outlet connections	1/2" adaptor for clamp fitting (clamp not supplied) on sample inlet. 6 mm O/D on sample outlet.	

2.3 Limiting conditions

Part	Design temperatures	Design pressure
Coil	572°F (300°C)	464 psig (32 barg)
	500°F (260°C)	638 psig (44 barg)
Body	248°F (120°C)	913 psig (63 barg)
	212°F (100°C)	145 psig (10 barg)
Cold hydraulic test pressure		232 psig (16 barg)

Clamp - The pressure and temperature rating is dependant on the clamp manufacturers recommendations.

3. Installation

Note: Before actioning any installation observe the 'Safety information' in Section 1.

- We recommend the use of corrosion resistant pipework suitable for the fluid being sampled.
- Keep the length of all pipes to a minimum.
- Cooling water must be clean and free of scale forming salts.
- The sample cooler must be mounted vertically, using the pre-drilled top and bottom mounting brackets (see Fig. 3).
- Allow sufficient space below the SSC20 for collection of the sample in a beaker or similar container. We recommend that a tundish piped to drain is located underneath this outlet. No connection is required on the sample OUT.
- Connect the pipework as shown in the drawing. The cooling water IN should be piped to the bottom of the sample cooler in 1/2" nominal bore pipe via a cooling water inlet valve. A 1/2" BSP/NPT male/female elbow makes a suitable connector.
- Pipe the cooling water OUT from the top of the sample cooler to an open drain or tundish.
Caution: to avoid the possibility of an air lock at the top of the sample cooler, do not allow the thread of the cooling water OUT elbow to protrude into the sample cooler body - maximum thread engagement 15 mm.
- Install the clamp fitting and seal in accordance with the manufacturer's instructions.

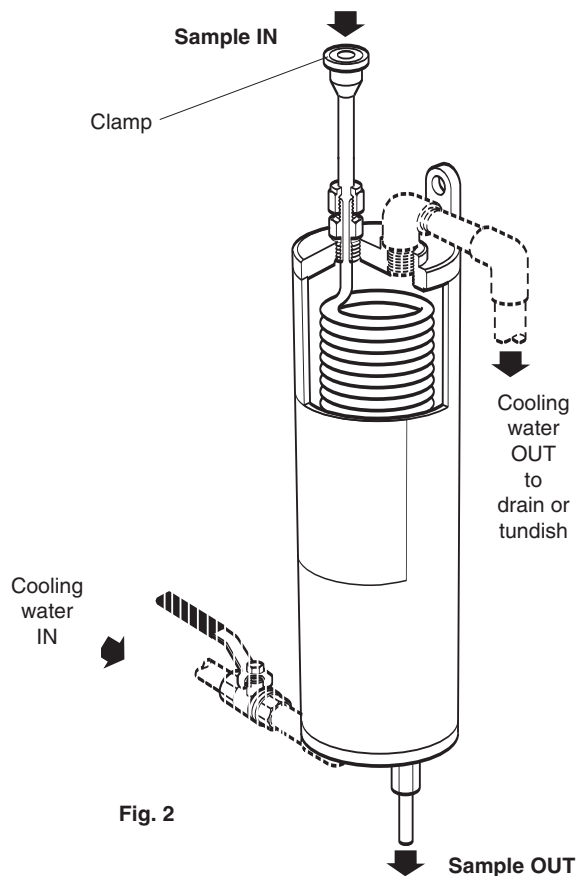

Fig. 2

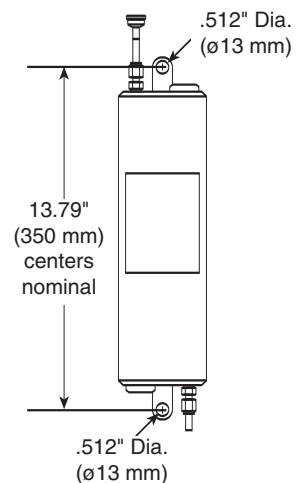

Fig. 3

4. Commissioning

After installation or maintenance carry out tests to ensure that the system is fully functional.

5. Operation

Warning:-

To avoid the risk of scalding, it is essential that a full flow of cooling water is present before opening the sample inlet valve.

Always close the sample inlet valve before turning off the cooling water.

Sample pipework becomes very hot under normal working conditions, and will cause burns if touched.

Follow this procedure for safe operation and accurate sampling:-

- Open the cooling water inlet valve first and ensure that a full flow can be seen at the cooling water outlet.
- Gradually open the sample inlet valve and regulate the flow to achieve a cooled sample at about 77°F (25°C).
- Allow the sample to run for a while before collection. This will ensure that a true sample is collected for analysis.
- When enough liquid has been collected close the sample inlet first, and then the cooling water inlet valve.
- After closing the sample inlet valve the sample OUT connection may drip for a few minutes while the coil drains.

6. Maintenance

No routine maintenance is required.

7. Spare parts

The following components are available as spares:

Component	Stock no.
Stud coupling stainless steel BSP	0963243

Spirax Sarco Applications Engineering Department
Toll Free at: 1-800-833-3246

SPIRAX SARCO, INC. • 1150 NORTHPOINT BLVD. • BLYTHEWOOD, SC 29016
PHONE 803-714-2000 • FAX 803-714-2222 • WWW.SPIRAXSARCO.COM/US