

CP32
Conductivity probe
Installation and Maintenance Instructions

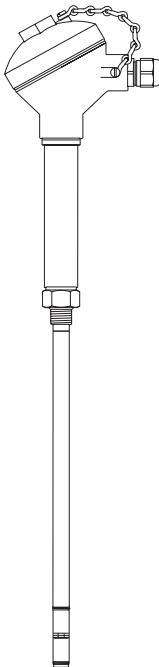

- 1. General safety information*
- 2. General product information*
- 3. Installation*
- 4. Wiring diagrams*
- 5. Maintenance*
- 6. Spare parts*
- 7. Fault finding*

1. General safety information

Your attention is drawn to the relevant Supplementary Safety Information Sheet supplied with the product as well as to any National or local regulations.

Safe operation of the product depends on it being properly installed, commissioned, and maintained by a qualified person in compliance with the operating instructions.

It is essential to comply with general installation and safety instructions for pipeline and plant construction, as well as to make proper use of tools and safety equipment.

The product is designed and constructed to withstand the forces encountered during normal use. Use of the product for any other purpose, or failure to install the product in accordance with these Installation and Maintenance Instructions, could cause damage to the product and may cause injury or fatality to personnel.

This product contains materials including PTFE which can give off toxic fumes if exposed to excessive heat.

Do not install the probe outdoors without additional weather protection.

Drain /vent holes must be kept clean - do not cover.

2. General product information

2.1 Application

The Spirax Sarco CP32 conductivity probe is used in conjunction with a controller to measure the conductivity (closely related to TDS) of water, usually in a steam boiler, for the purpose of monitoring and controlling blowdown.

2.2 Description

The CP32 is supplied in three nominal tip lengths, and has a $\frac{3}{8}$ " BSP thread ($\frac{1}{2}$ " NPT) for connecting to a Spirax Sarco probe elbow, a screwed flange, or directly into a boiler connection. The CP32 has a built-in temperature sensor, and when used with the BC3200 or BC3210 controller, is able to detect scaling (UK Patent No. 2297843). It also automatically initiates a probe conditioning cycle (UK Patent No. 2276943).

This causes any scale on the probe to become porous or disintegrate, allowing the probe to continue to sense at its original calibration level. **WARNING: This feature is not a substitute for a proper boiler water treatment regime. If scale is present on a probe, it indicates sealing is also occurring inside the boiler, and a competent water treatment specialist must be consulted to avoid a potentially dangerous situation.**

The probe is approved by Underwriters Laboratory (UL) as an accessory for use with the BC3200 and the BC3210 blowdown controllers. These controllers supply the probe with a low voltage limited power source. The UL electrical ratings for the probe are 20 Vdc and 14 Vac at 10 mA.

2.3 Available tip lengths mm (inches)

300 (11.8), 500 (19.7) and 1 000 (39.4)

Note: 1 000 mm probes must only be installed vertically.

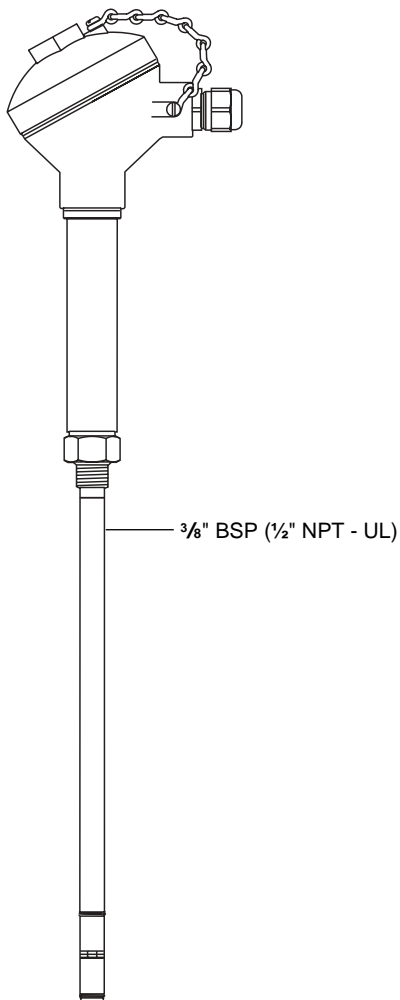

Fig. 1

2.4 Limiting conditions

Maximum boiler pressure	32 bar g	(464 psi g)
Maximum temperature	239°C	(462°F)
Maximum ambient temperature	70°C	(158°F)
Minimum tip distance from boiler tubes	10 mm	($\frac{3}{8}$ ")
Minimum immersion depth (vertically installed probes)	100 mm	(4")
Maximum cable length (probe to controller)	100 m	(330 ft)
Minimum conductivity	10 μ S/cm	or 10 ppm
Protection rating (terminal head/cable gland only)	IP65	

3. Installation

The CP32 is supplied in nominal tip lengths of 300, 500, or 1000 mm, (12", 20" and 39") and cannot be cut to length.

300 mm and 500 mm probes can be installed vertically or horizontally.

CAUTION: 1000 mm probes must be installed vertically only.

WARNING: Do not install the probe outdoors without additional weather protection.

WARNING: The boiler must be depressurised and vented to atmosphere before installation of the probe. Wherever possible the boiler manufacturer must be consulted for advice on the positioning of the probe and the optimum TDS level.

Always install the probe:

- In a position where it can sense the conductivity of the boiler water.
- As far away from the feedwater inlet as possible.
- As near to the centre line of the boiler as possible. This lowers the risk of it being in the steam bubbles normally found towards the top of the boiler, or in the higher concentration of suspended solids found at the bottom of the boiler.

Note: The tip of the probe must be 10 mm (2") away from any boiler tubes and project at least 55 mm (2 1/8") into the boiler. It may be necessary to make up a stand-off for certain installations in order to achieve these measurements. Vertically installed probes must be immersed to a minimum depth of 100 mm (4").

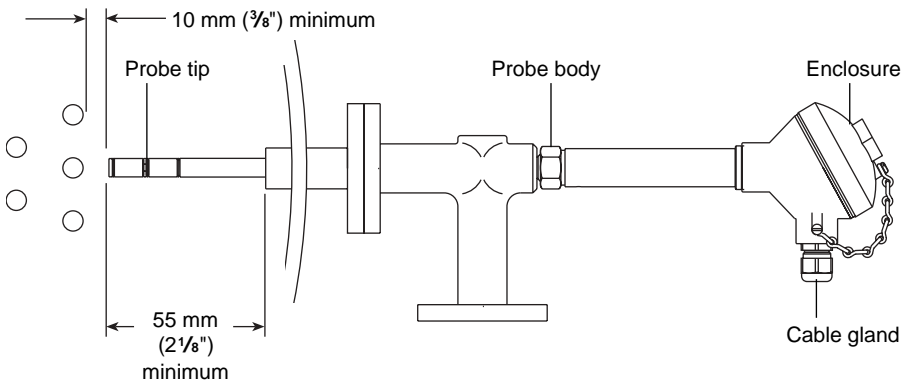

Fig. 2 Installation diagram

Install the probe as follows:

- Ensure male and female threads are in good condition.
- Use up to three turns (no more) of PTFE thread sealing tape on the probe thread.
- **WARNINGS: Do not use excessive tape. Do not use paste type jointing compound.**
- Fit and tighten the probe by hand initially, use a suitable spanner to tighten the probe. Under no circumstances use a pipe wrench.
- Due to the nature of a taper / parallel joint it is not possible to recommend tightening torque figures.
- Do not overtighten - there should always be visible thread on the probe.

Note: The probe thread will not 'bottom out' (i.e. probe body hexagon contacts the face of the female screwed connection), unless there is excessive wear or an out-of-tolerance female thread, in which case it will be necessary to replace or re-work the flange or connection.

Subsequent removal and refitting:

WARNING: Ensure boiler or vessel is depressurised and vented to atmosphere before attempting to unscrew or remove the probe.

- Always use the correct size spanner - not a pipe wrench.
- Inspect male and female threads for signs of damage, which may have occurred through overtightening, leading to torn threads or even localised cold welding (galling/picking up).
- If damage has occurred replace the probe.

4. Wiring diagrams

Cabling should be installed in accordance with BS 6739 - Instrumentation in Process Control Systems : Installation design and practice or local equivalent. For US and Canadian installations the probe must be wired in accordance with the National and Local Electrical Code (NEC) or the Canadian Electrical Code (CEC). An 8-way plug-in terminal block is provided in the terminal head to simplify wiring.

Wiring should be carried out using 7 core, 1 mm² (18 AWG), high temperature screened cable, with a maximum length of 100 metres (330 ft). Pirelli FP 200 or Delta Crompton Firetuf OHLS are two suitable types for the standard CP32.

For US and Canadian installations, Class 1 screened cable with a suitable temperature rating (75°C/167°F minimum) must be used for the wiring.

Connect the wiring and screens as shown in the diagrams below.

Caution:- Do not connect any wires to the smaller (five-way) terminal block, as it houses the very fine wiring from the probe which could be easily damaged in attempting to connect additional wires.

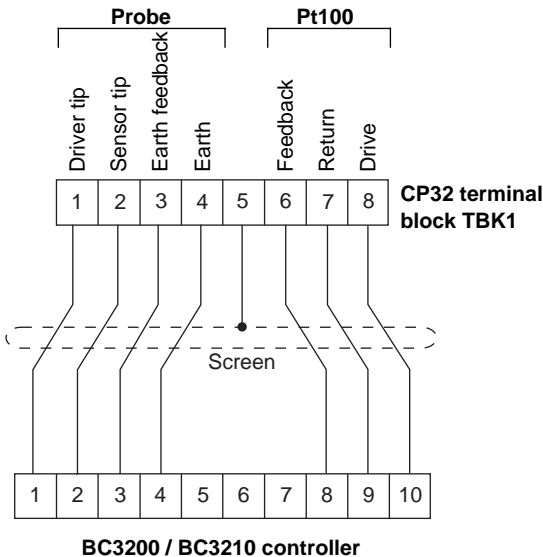

Ensure resistance from probe body to pipework/boiler shell is less than 1 Ω .

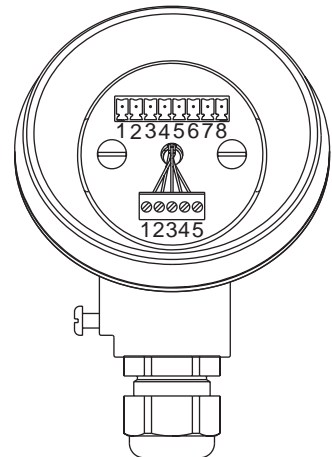

Wiring layout

Fig. 3 Wiring diagrams

5. Maintenance

The probe does not normally need regular maintenance. Remove, clean, and check the probe annually.

We also recommend that if the controller ever indicates a fault condition for over 12 hours that it is removed, checked, and cleaned.

If scale should start to form on the probe, then it will normally be removed/made conductive by the automatic conditioning system. However, this system is not a substitute for adequate water treatment, it is still possible that under very severe conditions the probe may need extra cleaning.

To clean the probe manually:

- Remove the probe and clean the tip with a wet cloth. For hard scale, fine wet-or-dry paper (600 grit maximum coarseness) may be used.
- Refit the probe using PTFE tape rather than paste-type compound. See Section 3 'Installation'.

6. Spare parts

The following parts are available as spares:

- Enclosure 'O' ring.
- Eight way plug-in terminal block.

7. Fault finding

Problems experienced during commissioning are often found to be due to incorrect wiring or setting up, so we recommend that a thorough check is first carried out.

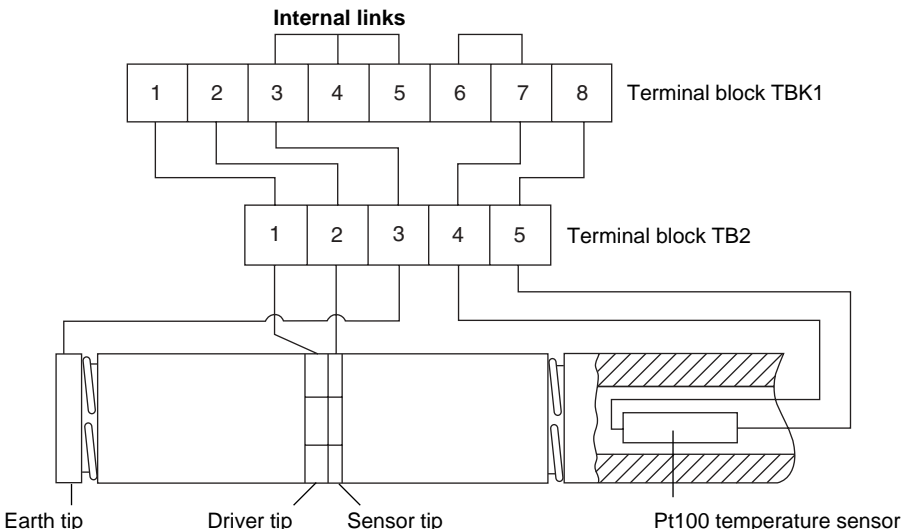

Fig. 4 CP32 Internal wiring diagram

Checking probe condition using the probe cell constant:-

The BC3200 / BC3210 controllers have a facility which allows the condition of the probe driver tip to be checked without removing the probe from the boiler. This is done by calculating an approximation of the probe cell constant, an indication of the probe condition.

A probe driver tip which is functioning correctly without excessive scaling will have a cell constant of between 0.2 and 0.6. See the 'Fault finding' Section of the BC3200 / BC3210 Installation and Maintenance Instructions for details.

The sensor tip condition cannot be checked by this method.

Checking the probe condition using the MS1:-

The condition of an installed probe can be checked by using a Spirax Sarco MS1 conductivity meter and its extension lead. See CP32 internal wiring diagram below.

Driver tip:

- Disconnect the 8-way plug from the probe terminal block TBK1.
- Connect the MS1 extension lead between terminal 1 and terminal 3.
- Use the reading to calculate the driver tip cell constant as described in the MS1 instructions. A cell constant in the region of 0.2 to 0.6 would indicate that the probe is working correctly. A high figure indicates that the probe is scaled.

Sensor tip:

- As for driver tip, but connect the MS1 between terminals 2 and 3. A sensor tip cell constant of 0.2 to 0.6 is normal, but a figure up to 0.8 is satisfactory.

Pt100 resistance check:

- The power must be off for this check.
- Measure the resistance between terminal 7 and terminal 8 on TBK1. A conventional ohm meter may be used for this test. Resistance should be between 100 ohms (0°C / 32°F) and 168 ohms (180°C / 356°F). Internal links may be checked by reference to the diagram. Terminal 3 should be earthed to the probe body.

Caution:- Do not attempt to dismantle the CP32. No spare parts are needed, and there are no user-serviceable parts in the probe.

