

**SP400**

**Electropneumatic Smart Positioner**  
**Installation and Maintenance Instructions**

---

---



1. *Index*
2. *Safety information*
3. *Technical information*
4. *Options*
5. *Installation*
6. *Electrical connections*
7. *Quick start procedure*
8. *Programming*  
*flow chart*
9. *Programming and*  
*commissioning*
10. *Maintenance*
11. *Default values and*  
*program settings*
12. *Glossary of*  
*display data*

---

# 1. Index

---

<b>Section</b>	<b>Sub-section</b>
<b>2. Safety information</b>	2.1 General requirements
	2.2 Electrical safety requirements
	2.3 Electromagnetic compatibility
<b>3. Technical information</b>	3.1 Description
	3.2 Technical data
	3.3 Materials
	3.4 Programmable functions
<b>4. Options</b>	4.1 Pressure gauge block
	5.1 Mounting the SP400 positioner - General informaton
<b>5. Installation</b>	5.2 Sequence for mounting an SP400 positioner to a linear actuator
	5.3 Sequence for mounting an SP400 positioner to a rotary actuator
	5.4 Air supply and connections
<b>6. Electrical connections</b>	6.1 Guidance notes
	6.2 Wiring diagrams
<b>7. Quick start procedure</b>	7.1 2-port valves
	7.2 3-port valves
<b>8. Programming flow chart</b>	
<b>9. Programming and commissioning</b>	9.1 SET-UP NOW
	9.2 SP400 MENU
	9.3 MANOP
	9.4 AUTOS - automatic autostroke commissioning
	9.5 SET - setting of valve functions
	9.6 RUN - automatic operation
<b>10. Maintenance and troubleshooting</b>	10.1 Air supply quality
	10.2 Fitting replacement filter plug kit
<b>11. Default values and program settings</b>	
<b>12. Glossary of display data</b>	12.1 Main menu display functions
	12.2 Sub-menu display functions

---

## 2. Safety information

---

### 2.1 General requirements

The flawless and safe operation of the SP400 positioners is reliant on proper transportation, storage, installation and commissioning by qualified personnel, proper use and careful maintenance.

Prior to installing, using or maintaining the positioner, consideration should be given to:

- The working environment.
- Safe access.
- Lighting.
- Pipeline fluid hazards.
- Temperature.
- System isolation.
- Location.

The SP400 positioner should be mounted with sufficient space to allow opening of the hinged cover and to provide access for electrical and air connections. When fitting to an actuator, ensure that the positioner will not be exposed to an ambient temperature outside the range of -10°C to +80°C. The positioner enclosure is rated to IP65 (see BS EN 60534-1 1998).

### 2.2 Electrical safety requirements

The SP400 is a class III product which must only be powered from Safe Extra Low Voltage (SELV) sources whether by virtue of a 4 - 20 mA control signal or from a separate power supply. Similarly all signal circuits connected to an options board must operate within the confines of SELV systems. All associated wiring must be separated from other wiring containing hazardous voltages.

### 2.3 Electromagnetic compatibility

The product complies with the Electromagnetic Compatibility Directive 2004 / 108 / EC according to:

- EN 61326-1: 2006
- EN 61326-2-3: 2006
- EN 55011: 1998 + A1: 1999 + A2: 2002
- EN 61000-4-2: 1995 + A1: 1998 + A2: 2001
- EN 61000-4-3: 2006
- EN 61000-4-4: 2004
- EN 61000-4-5: 2006
- EN 61000-4-6: 2007
- EN 61000-4-11: 2004

This product may be affected by interference if:

- The product or its wiring is located near a radio transmitter. The actual separation necessary will vary according to the power of the transmitter.
- Cellular telephones or mobile radios are used within approximately one metre of the product or its wiring.
- The wiring is routed alongside power cables subject to high voltage transients or current surges.

# 3. Technical information

## 3.1 Description

The SP400 smart valve positioner is loop powered from a 4 - 20 mA input signal to provide accurate adaptive positional control of pneumatic actuated linear and quarter turn valves. Precise control is maintained through valve position feedback that automatically varies the pneumatic output pressure to overcome the effects of stem friction and flow forces to maintain desired valve position. Indication of valve position is provided through a continuous digital display of % travel. Valve position feedback is retrieved by means of a non contact technology based on Hall effect. The pneumatics are based on piezovalue technology - Therefore, high resolution, high reliability, vibration insensitivity and extremely low air consumption is guaranteed at steady state.

The SP400 includes many smart functions that can be fully programmed through menu driven software using an integral keypad and LCD alphanumeric data. The absence of mechanical linkages between valve stem and positioner, drastically simplifies the mounting procedure and reduces the time required. Moreover the software has been designed to simplify operations as much as possible: commissioning requires just assembling the SP400 to the valve and pressing one button. The SP400 is supplied with a NAMUR standard mounting kit for attachment to yoke or pillar mounted actuators. For quarter turn valves, a mounting kit compliant to VDI/VDE 3845 is supplied.

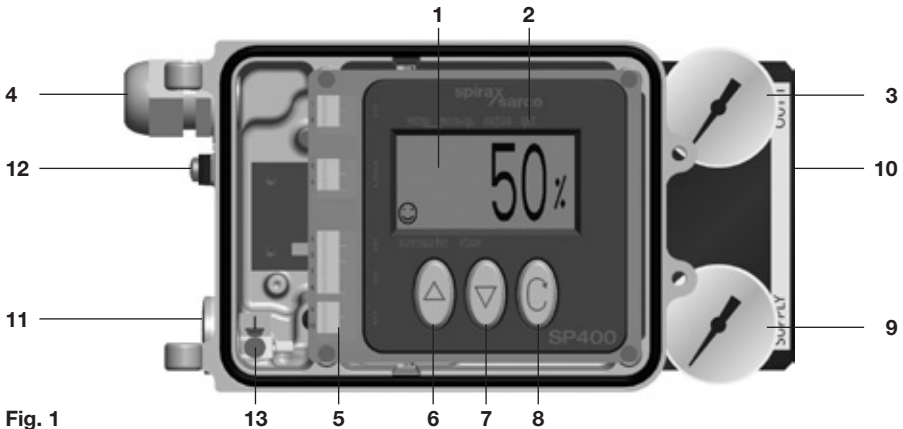


Fig. 1

No.	Part
1.	LCD display
2.	Main menu functions with LCD flag indication
3.	Signal pressure to actuator
4.	Gland connection for wiring M20
5.	Terminal block
6.	Increase value or toggle value key
7.	Decrease value or toggle value key
8.	Enter key
9.	Supply pressure to positioner
10.	Optional pressure gauge block with gauges
11.	Spare M20 gland connection for wiring a 4-20 mA retransmission or software switches
12.	External earth
13.	Internal earth

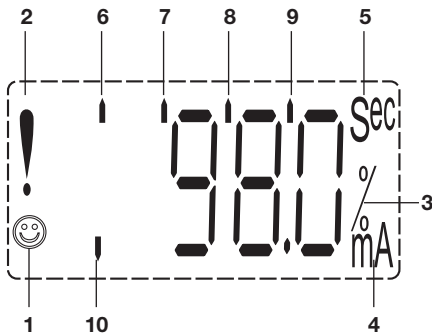


Fig. 2

**No. Features**

1. 😊 indicates all is OK
2. ! Indicates a delay in positioning, this disappears when the position is reached
3. Indicates that the value displayed is a percentage
4. Indicates that the value displayed is the input current measured in mA
5. Indicates that the value displayed is a time measured in seconds
6. Indicates that you're accessing the main programming menus
7. Indicates that the positioner is in manual mode
8. Indicates that the positioner is running the autocalibration
9. Indicates that you're accessing the SET menu
10. Indicates that the positioner is in automatic mode

**3.2 Technical data**

<b>Input signal range</b>	4 - 20 mA nominal	
<b>Minimum input signal (loop powered)</b>	3.6 mA	
<b>Minimum air supply pressure</b>	1.4 bar g	
<b>Maximum air supply pressure</b>	7 bar g	
<b>Air quality</b>	Air supply must be dry, oil and dust free to ISO 8573-1 class 2:3:1	
<b>Output pressure</b>	0 to 100% supply pressure	
<b>Stroke range</b>	Linear valves	10 mm to 100 mm
	Quarter turn valves	5° to 120°
<b>Action</b>	Single action / fail vent	
<b>Operating temperature</b>	-10°C to +80°C	
<b>Maximum air flow</b>	4.2 normal m³/h at 1.4 bar g <b>or</b> 8.5 normal m³/h at 6 bar g	
<b>Steady state air consumption</b>	Less than 0.016 normal m³/h	
<b>Air connections</b>	Screwed ¼" NPT	
<b>Cable gland</b>	M20	
<b>Electrical connections</b>	Spring clamp terminals for 0.2 to 1.5 mm² wire	
<b>Enclosure rating</b>	IP65	
<b>Characteristic</b>	Linear	
<b>Resolution (maximum)</b>	0.1% F.S.	
<b>Shut-off</b>	1%	
<b>Shipping weight</b>	2.2 kg	

### 3.3 Materials

Part	Material	Finish
Case and cover	Die cast aluminium	Anti-corrosive paint to RAL5010
Magnet bracket	Die cast aluminium	

### 3.4 Programmable functions

Autostroke	Automatic commissioning routine		
Valve type	2-port or 3-port		
% travel	Selectable 0 to 100% or 100% to 0% depending on valve / actuator configuration		
Control action	Direct or reverse action (4 - 20 or 20 - 4 mA)		
Split range	OFF	range	4-20 mA
	LOW	range	4-13 mA
	HIGH	range	11-20 mA
Deadband	0.5%		
	1.5%		
	3.0%		
	5.0%		
Reset	Resets all programmed values to default settings		
Input signal	Visualisation of input mA signal		



---

## 5. Installation

---

### 5.1 Mounting the SP400 positioner - General information

**Preliminary check of valve and actuator assembly** - A preliminary check should be carried out on the valve and actuator assembly prior to mounting and commissioning the SP400 positioner to confirm smooth movement of the stem. This can be performed by providing an air supply directly from a filter/regulator to the actuator. The air supply pressure should be gradually increased to progressively move the stem through its full travel. Any friction or jerky movement of the stem should be investigated prior to commissioning the SP400.

- 5.1.1** The SP400 is supplied with a NAMUR standard fixing kit for linear actuators (yoke or pillar) or with a VDI/VDE 3845 compliant mounting kit for rotary actuators.
- 5.1.2** The SP400 has an enclosure rating of IP65 and should be installed in a location that will not exceed its ambient temperature limits of -10°C minimum and +80°C maximum.
- 5.1.3** Before fitting and commissioning the SP400 positioner ensure that the valve and actuator are correctly assembled. Refer to the valve and actuator Installation and Maintenance Instructions for details.

---

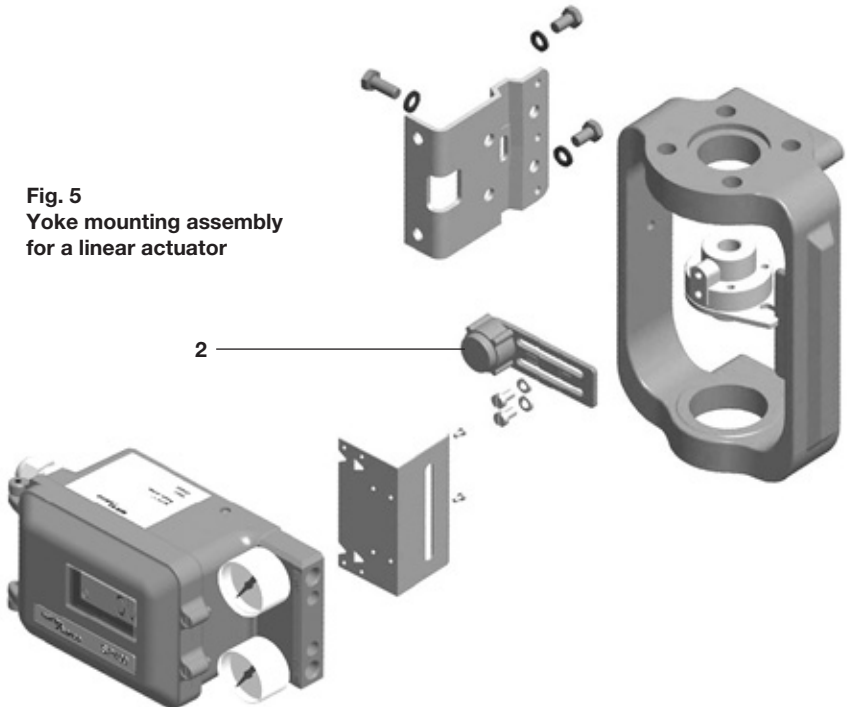
## 5.2 Sequence for mounting an SP400 positioner to a linear actuator



**Fig. 4** Pillar mounting kit for a linear actuator

- 5.2.1** Loosely attach the magnet bracket (2) to the valve / actuator connector (refer to Figures 4 and 5). Be sure it is positioned horizontally (as shown in Figure 5).

**Fig. 5**  
Yoke mounting assembly  
for a linear actuator



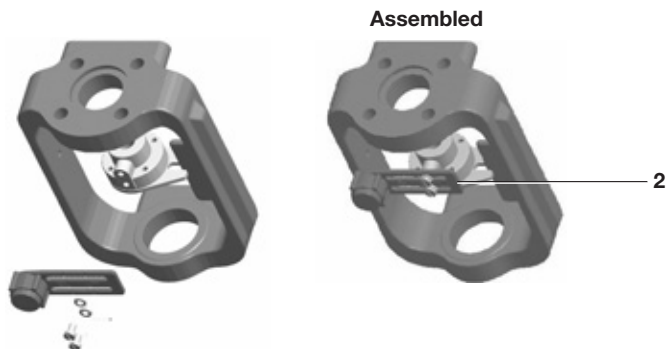


Fig. 6

**5.2.2** Slide the bracket (2) to the left or to the right (Figure 6) till the correct position is achieved. If you're using a Spirax Sarco actuator the correct position is impressed on the magnet bracket (Figure 7).

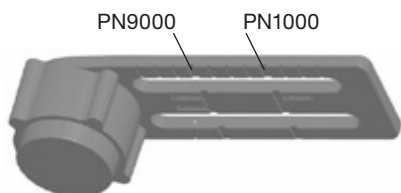


Fig. 7 Bracket markings

**5.2.3** If you're not using a Spirax Sarco actuator, slide the bracket till the distance 'A' between the center of the magnet and the inner side of the mounting plate is 25 mm (Figure 8).

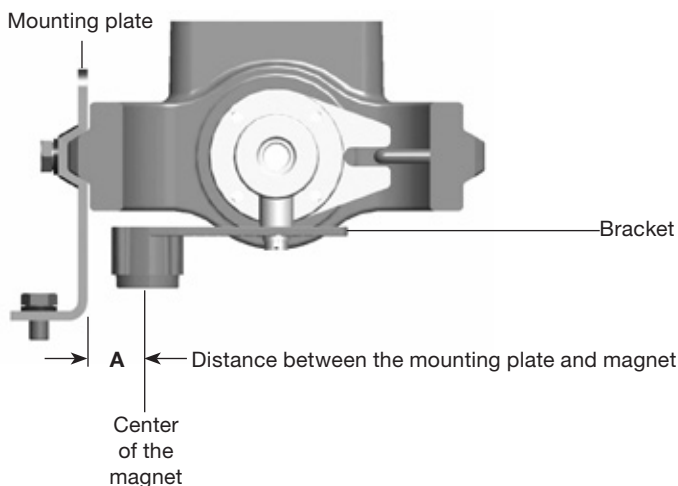
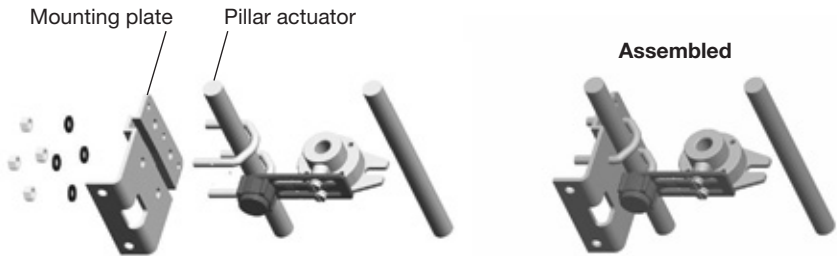
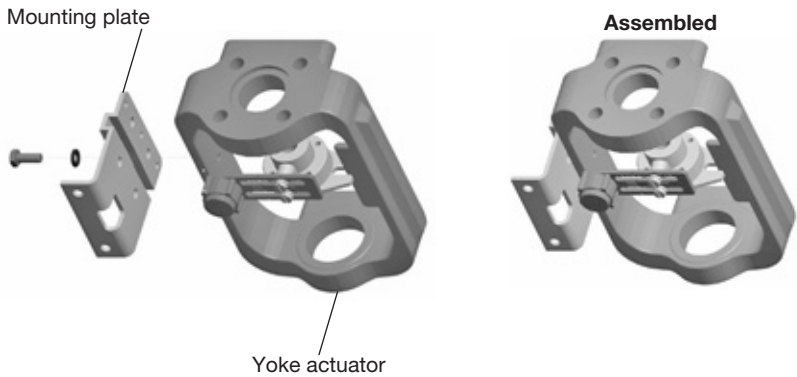


Fig. 8

**5.2.4** Loosely attach the positioner mounting plate to the actuator as shown in the following pictures: for the pillar actuator (Figure 9), and for the yoke actuator (Figure 10).

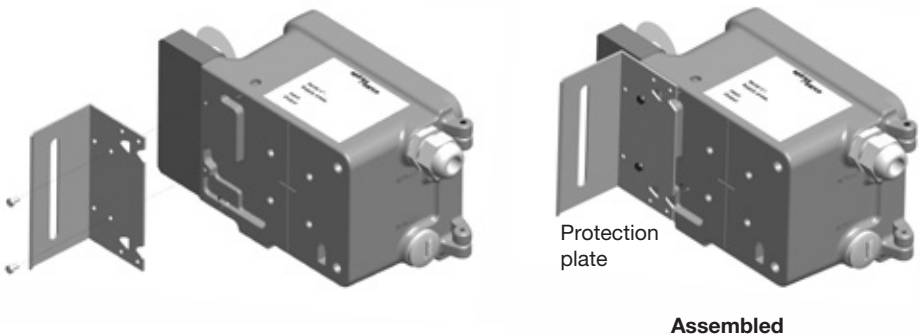


**Fig. 9** Pillar actuator assembly



**Fig.10** Yoke actuator assembly

**5.2.5** Locate the protection plate onto the back of the SP400 positioner housing and fix in place (Figures 11 and 12).

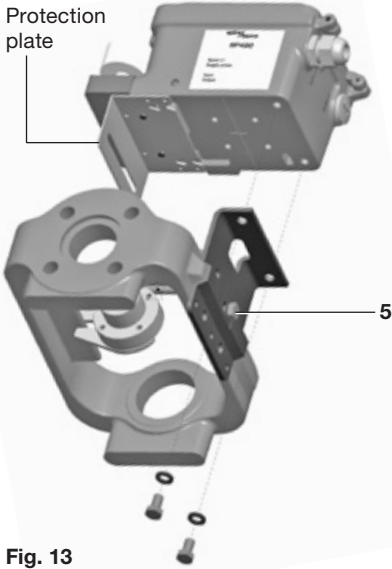


**Fig. 11**

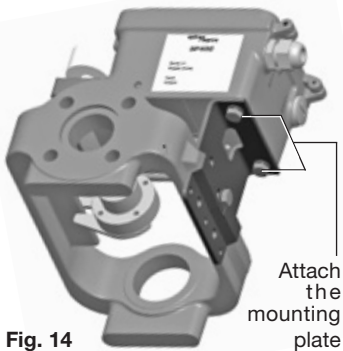
**Fig. 12**

### 5.2.6

Attach the positioner mounting plate to the positioner as shown in Figures 26 and 27.



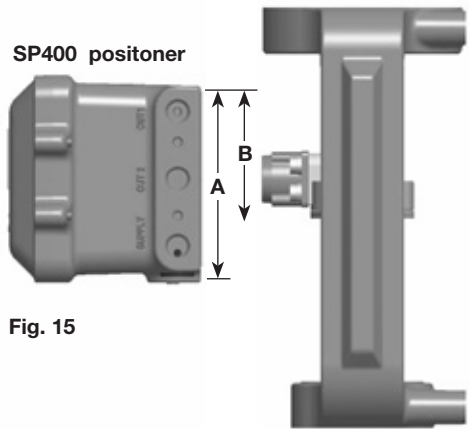
Assembled



### 5.2.7

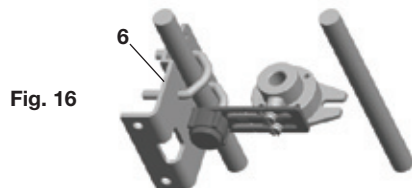
Adjust the vertical position of the SP400 positioner and mounting plate assembly, by sliding it up or down on the pillar style actuators, ensuring that the positioner is roughly centred on the actuator/valve stroke (Figure 10).

Even if this is the ideal condition, it's not mandatory. In fact, as shown in Figure 15, the only necessary condition for correct operation is that the stroke of the magnet (dimension **B**) lay inside the sensor operating linear range (dimension **A**), i.e. the vertical dimension marked on the case of the positioner.



### 5.2.8

When the SP400 positioner and mounting plate assembly is correctly positioned, tighten the hexagon headed screw (5) on the yoke mounted actuator (Figure 13) to 10 - 12 N m and tighten the 'U' bolt nuts (6) on the pillar mounted actuators (Figure 16) to 10 - 12 N m.



---

## 5.3 Sequence for mounting an SP400 positioner to a rotary actuator

### 5.3.1 Assembly for fitting an SP400 on to a ¼ turn valve.

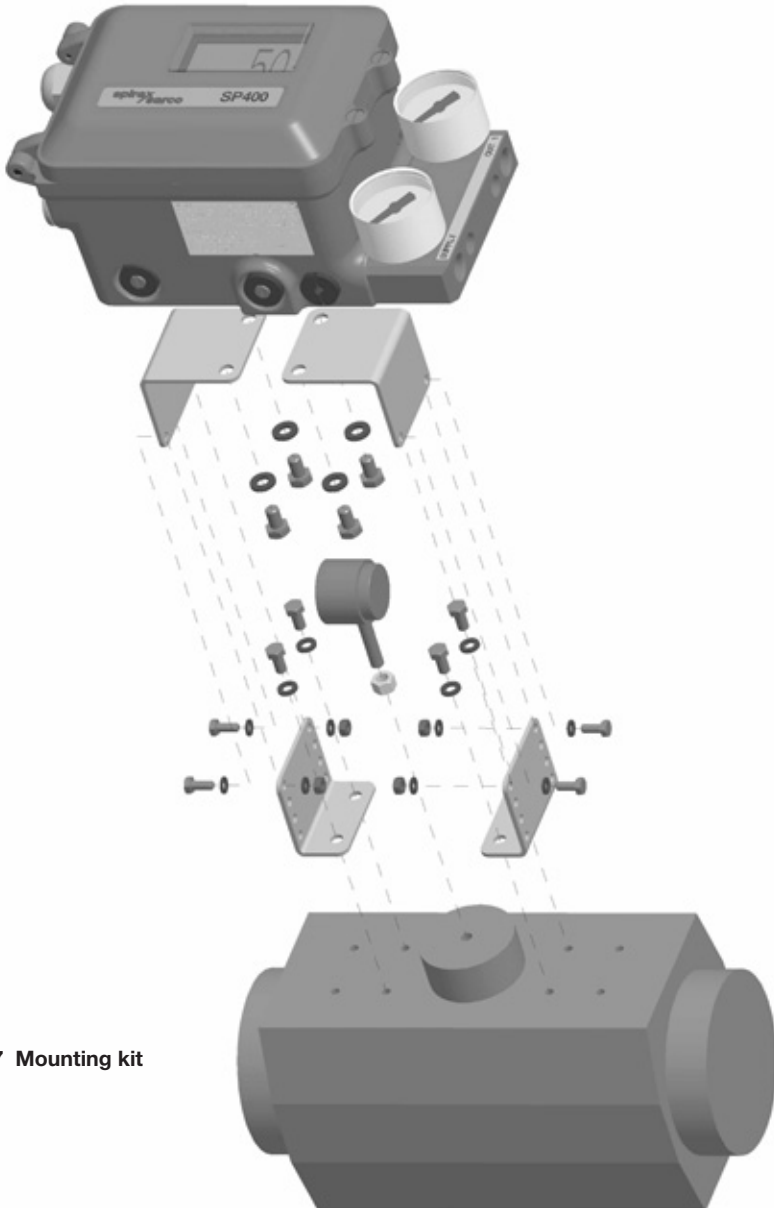


Fig. 17 Mounting kit

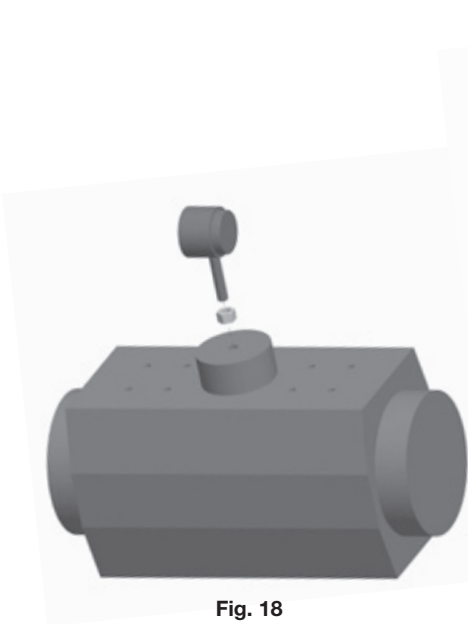


Fig. 18

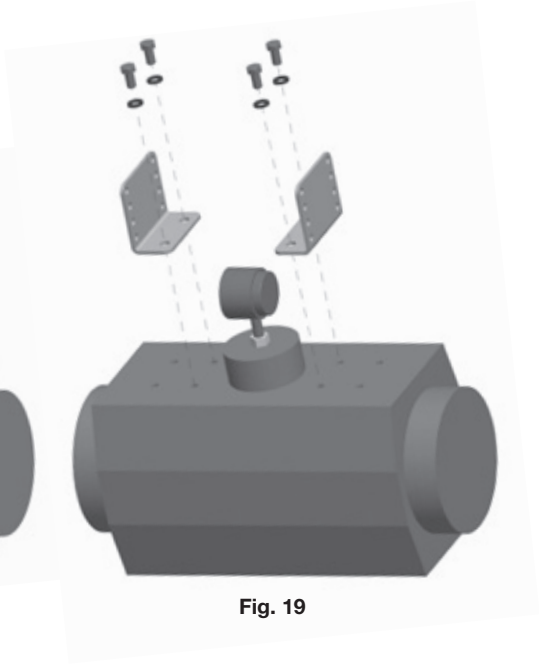


Fig. 19

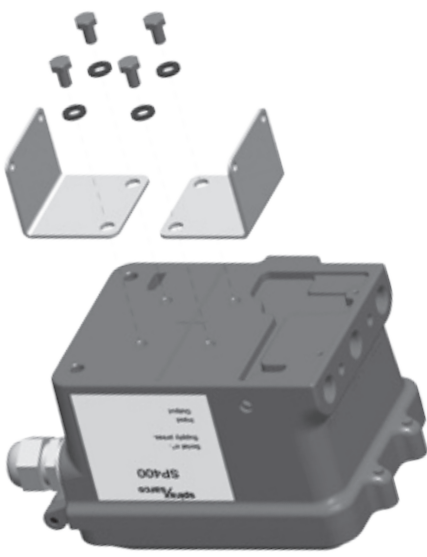


Fig. 20

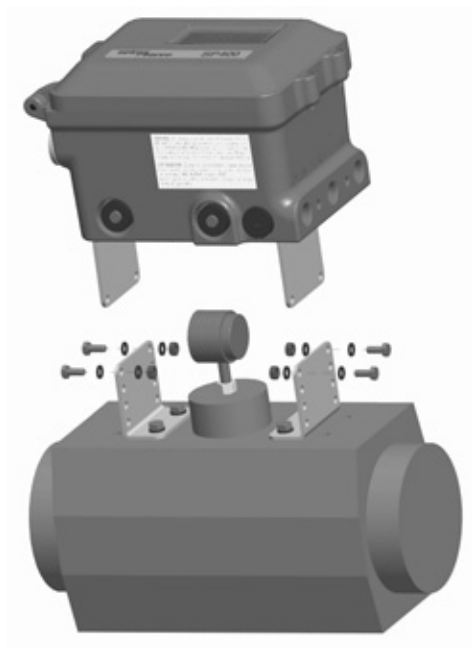


Fig. 21

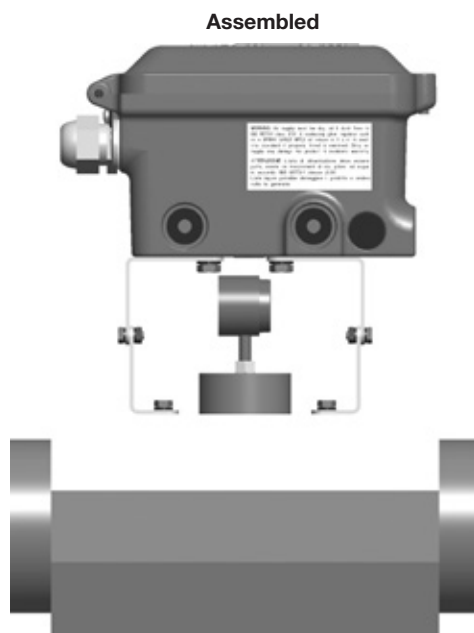
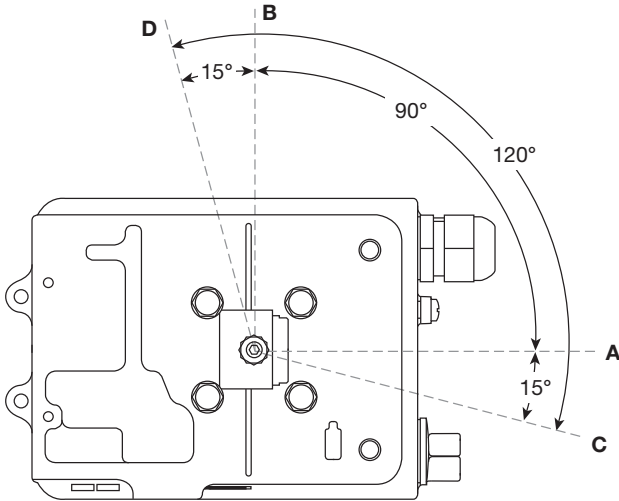
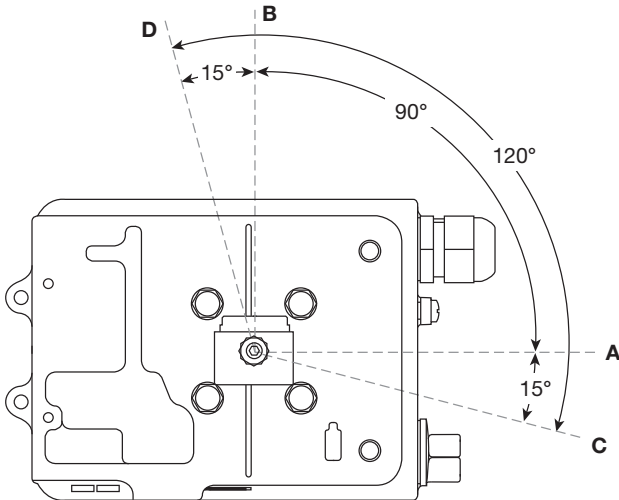


Fig. 22

**5.3.2** Adjust the magnet orientation as illustrated in Figures 23 and 24 and tighten the bolt to fix the magnet into position. There should be a distance of between 5 and 14 mm between the magnet and the positioner.  
 Refer to Figure 23 for actuator with clockwise rotation.  
 Refer to Figure 24 for actuator with anti-clockwise rotation.  
 In fact, in this way the magnet movements will always be comprised in the sector between the directions **C** and **D** which delimit the operating area of the Hall sensor.



**Fig. 23** View from the bottom of the positioner - Magnet orientation for clockwise actuator.



**Fig. 24** View from bottom of the positioner - Magnet orientation for anti-clockwise actuator.

---

## 5.4 Air supply and connections

**WARNING: Supply air pressure must not exceed the maximum allowable air pressure of the actuator.** Air connections should be ¼" NPT for air supply (supply) and output signal to actuator (Figure 25).

The supply air should be between 1.4 bar g minimum and 6 bar g maximum and be oil and dust free to IEC 60770. Mains air supply may sometimes contain traces of dirt, rust, water, oil and other deposits with the potential for contaminating the internals of the positioner. It is therefore essential that a filter / regulator is fitted in the mains air supply to the positioner. The filter / regulator should have a coalescing filter such as a Spirax Sarco type MPC2, or suitable compressed air pipework is used.



Fig. 25

# 6. Electrical connections

## 6.1 Guidance notes on wiring installation

For heavy industrial applications it is recommended to use screened cables or signal cables run in metal conduit. Failure to do so could result in positional errors of up to  $\pm 5\%$  in an RF field excess of 10 V/m. If screened cables are used, ensure that the screen is connected to the local earth at one end with a connection resistance of less than 1 ohm.

For light industrial applications where RF fields do not exceed 3 V/m unscreened cables may be used.

Cabling should be installed in accordance with BS 6739 - Instrumentation in Process Control Systems: Installation design and practice or local equivalent.

## 6.2 Wiring diagrams

### 6.2.1 Terminal block

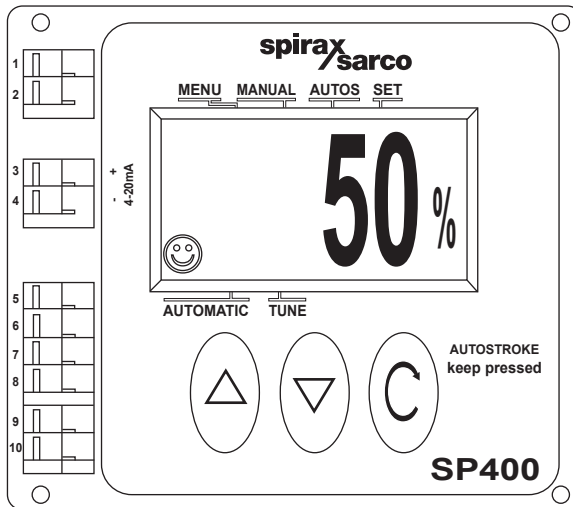


Fig. 26

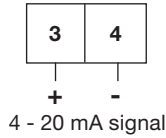
No.	Pole	Description	
1	+	Not used	Mainboard
2	-		
3	+	4-20 mA current signal input	
4	-		
5	+	Not used	
6	-		
7	+	Not used	
8	-		
9	+	Not used	
10	-		

## 6.2.2 Single loop applications

The SP400 is loop powered using the 4 - 20 mA input signal source providing a minimum signal of 3.6 mA can be maintained.

Minimum current	3.6 mA
Maximum current	30 mA
Maximum voltage drop	< 7 V
Overvoltage protection	Up to 30 Vdc
Protection against polarity inversion	Up to 30 Vdc

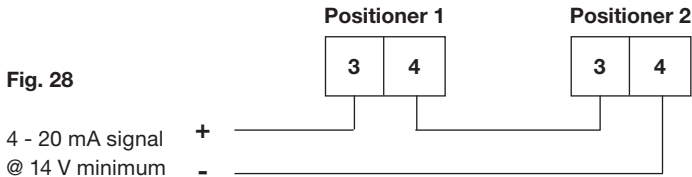
Fig. 27



## 6.2.3 Multi-loop applications

### Loop powered multi-positioner connections

Fig. 28



In a loop powered application, the 4-20 mA signal must be capable of supplying a minimum of 7 V per positioner at 20 mA. In a split range application the signal source must be capable of supplying sufficient voltage, i.e. 14 V is enough to power 2 positioners.

# 7. Quick start procedure

## 7.1 2-port valves

The following applies to positioners fitted to 2-port valves having plug above the seat and fitted to pneumatic actuators having a direct acting (DIR) 4 - 20 mA input signal and excludes the setting of any additional program functions (i.e. default value only).

**Note:** For PN5100 and PN6100 series actuators an additional programming step is required. (Refer to Section 9.5.2).

**7.1.1** The positioner should be correctly assembled as described in Section 5 and Section 6 and supplied with mains air and signal pipework as described in Section 5.4.

**7.1.2** Provide a minimum input signal of 3.6 mA to the positioner.  
**SET-UP NOW** should be displayed.

**7.1.3** Ensure that upstream isolation valves are closed.  
Press and hold the **C** key for 3 seconds to advance to the **SP400 MENU**.  
The display will count down the 3 seconds.

**7.1.4** Press the **▼** key to advance to **MANOP**.

**7.1.5** Press and hold the **C** key for 3 seconds to enter manual control mode **MCTL**.

**7.1.6** In manual control press and hold the **▲** or **▼** key to drive the valve stem up or down. Check for any obstructions of valve movement.  
The display will indicate **FILL** or **VENT** as appropriate.  
Any obstruction should be investigated before proceeding to Section 7.1.7.

**7.1.7** Press the **C** key to return to **MANOP** in main menu.

**7.1.8** Press and hold the **C** key for 6 seconds to start the autostroke routine.  
This will take approximately 2 minutes to complete.

**!** displayed indicates an incomplete or unsuccessful autostroke.

The routine can be aborted at any time by pressing the **C** key once.

If autostroke is aborted during operation **ABORT** will be displayed and **!** to indicate incomplete autostroke.

On completion the program will automatically return to **AUTOS** in main menu.

A **☺** will be displayed if successful autostroke has been completed.

**7.1.9** The valve will move to a control position related to the input control signal.  
The percentage valve travel will be displayed **%**.  
The positioner cover can now be closed and cover screws tightened.

---

## 7.2 3-port valves (with travel setting (TRAVL) 0 - 100%, refer to Figures 14 and 15)

Proceed as above up to Section 7.1.8.

- 7.2.1 On completion of a successful autostroke press and hold the **C** key for 3 seconds to access the SP400 MENU.
- 7.2.2 Press the **▼** key three times to access **SET**.
- 7.2.3 Press the **C** key once to advance to **VALVE TYPE**.  
Press the **▲** key to indicate **VALVE 3-PORT**.
- 7.2.4 Press the **C** key to select **VALVE 3-PORT**. Continue to press the **C** key to return to **SET** in the main menu.
- 7.2.5 Press the **▼** key twice to advance to **RUN** in the main menu.
- 7.2.6 Press and hold the **C** key for 3 seconds to commence automatic operation. The valve will move to a control position related to the input control signal. The percentage travel will be displayed %. The positioner cover can now be closed and the cover screws tightened.

# 8. Programming flow chart

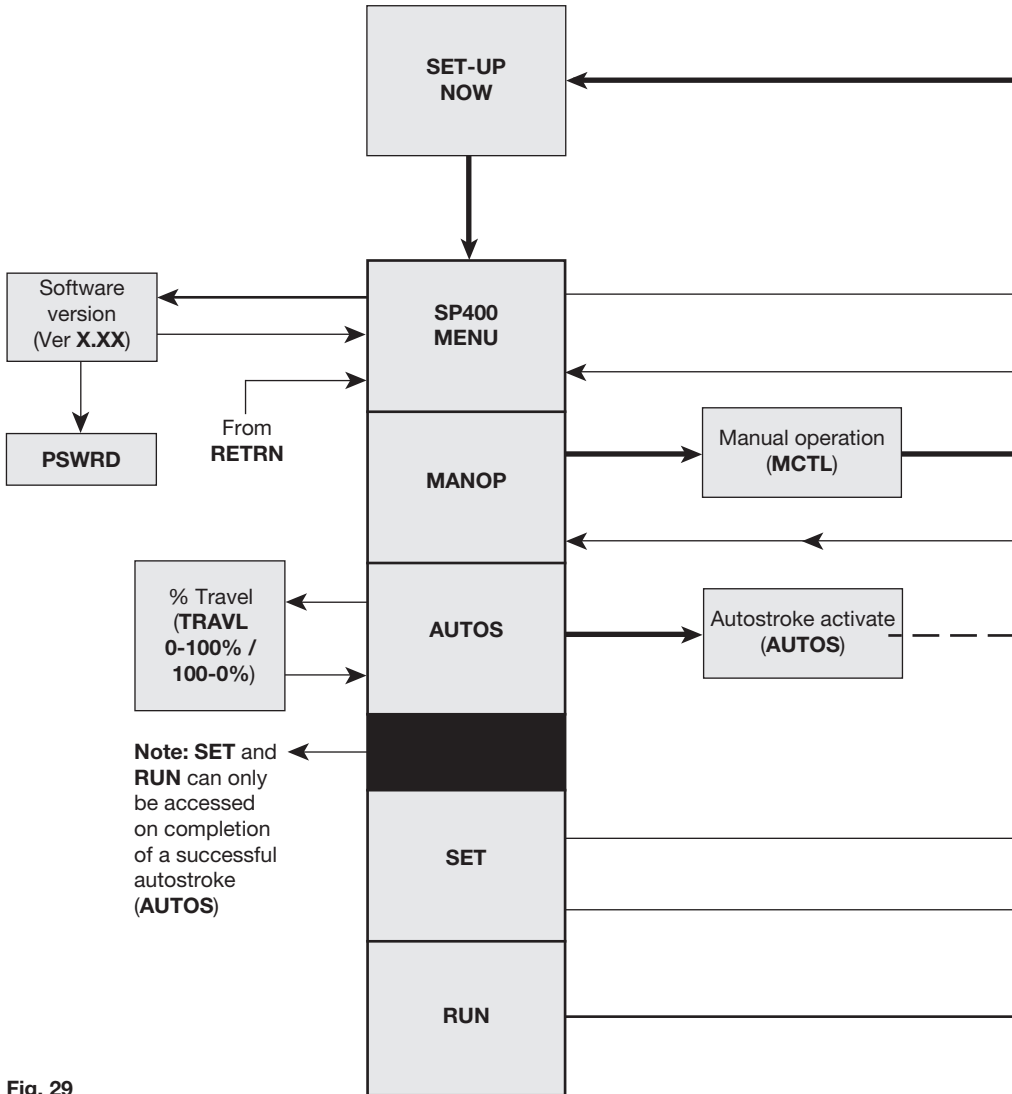
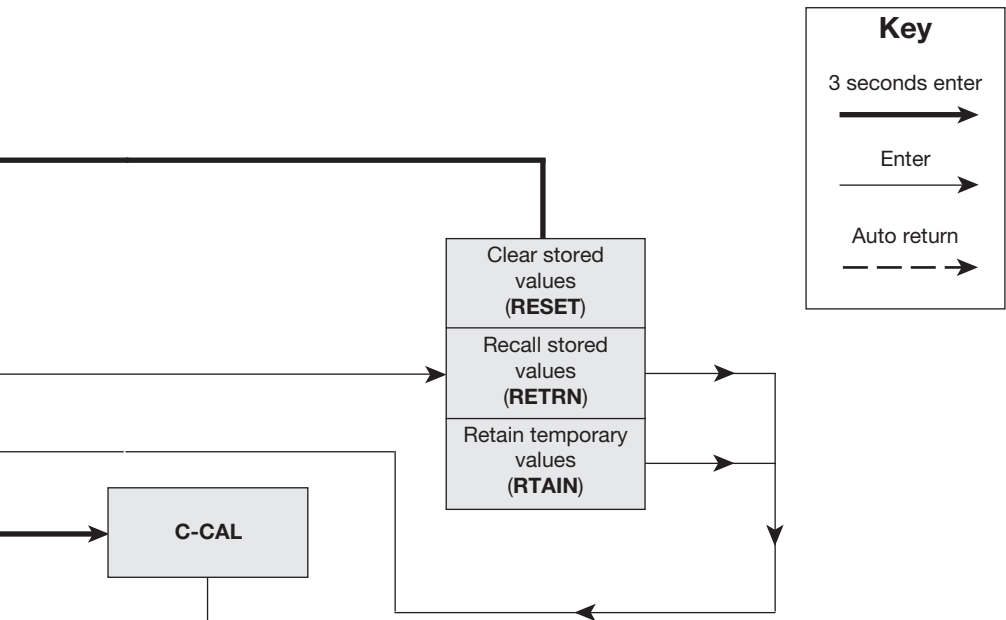
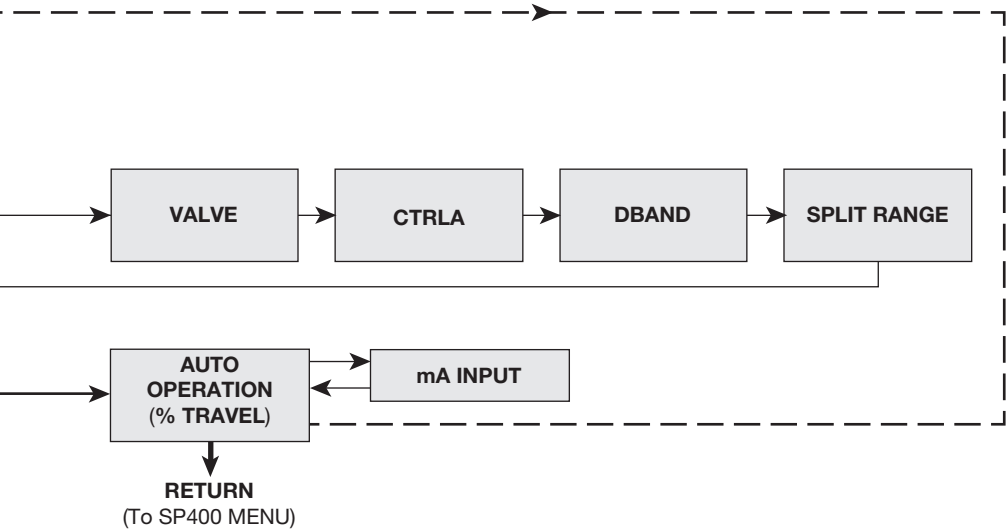


Fig. 29



**Key**

- 3 seconds enter → (thick solid arrow)
- Enter → (thin solid arrow)
- Auto return → (dashed arrow)



# – 9. Programming and commissioning –

## 9.1 Set-up now

### Programming notes

The positioner fitted to this control valve requires programming. A minimum input signal of 3.6 mA is required to power the positioner. To program the positioner it is necessary to enter the **SP400 MENU** and carry out an autostroke commissioning routine (**AUTOS**) prior to putting the control valve into automatic operation.

A flow chart is included in Section 8 to guide you through the procedure. The display provides a flag indication of the active main menu function.

To enter the **SP400 MENU** press and hold the **C** key for 3 seconds. The display will count the 3 seconds.

### Commissioning notes

**Main menu functions include:**

**SP400 MENU** View software version, mounting position check, reset default values.

**MANOP** Manual control of valve movement (Actuator inflation / deflation).

**AUTOS** Automatic valve commissioning. Provides selection of % travel display.

**SET** Setting of valve type, control action, input signal span and deadband.

**RUN** Activates automatic operation plus input signal, total valve strokes and total run time. Also provides route for returning to the **SP400 MENU**.

**Note:** **SET** and **RUN** functions are restricted and can only be accessed on completion of a successful autostroke routine (**AUTOS**).

In order to make commissioning as fast and simple as possible, you can run the autocalibration routine directly from the following menus: **SETUP NOW**, **SP400 MENU**, **MANOP**, **SET**, **RUN**. Keep the **C** key pressed for 6 seconds and the autostroke will start. At the end of the routine the positioner will enter into automatic mode and move the valve according to the current signal received. This means that once you have checked the functionality and safety of the assembly, you can commission the valve by just pressing one button.

## 9.2 SP400 MENU

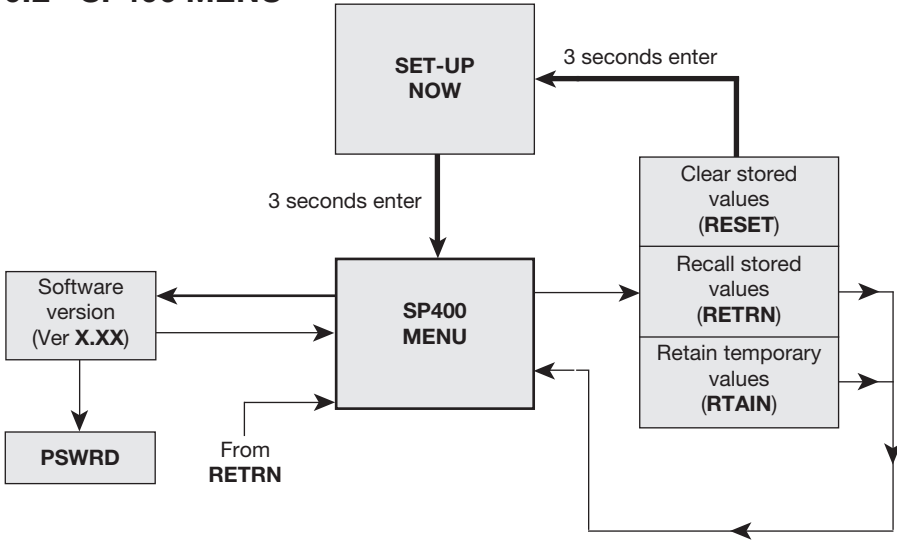


Fig. 30

### Programming notes

You are now in the **SP400 MENU**.

#### SP400 functions include:

1. Visualisation of the embedded software version (**VER--**).
2. Positional setting (**CALIB**).
3. Resetting of programmed values to default settings (**RESET**).
4. To retain settings in the temporary memory (**RTAIN**).
5. Returning to previously stored settings (**RETRN**).

Press and hold the **C** key for 3 seconds. The display will count the 3 seconds and access to **RESET / RTAIN / RETRN** functions.

To view the embedded version of software (**VER--**) press the **C** key. To advance to manual operation (**MANOP**) press the **▼** key.

### 9.2.1 VER --- software version

#### Programming notes

To view the version of the embedded software (**VER--**) press **C** key.

Press the **C** key to return to the **SP400 MENU**. The display will automatically return to the **SP400 MENU** after 10 seconds.

Press and hold the **C** key for 3 seconds to access the **PSWRD** menu.

---

## 9.2.2 PSWRD menu

This menu allows the user to upgrade an SP400 to an SP500 smart positioner. Contact our offices for further details.

## 9.2.3 RETRN - RTAIN - RESET

### Programming notes

Provides the facility to restore previous permanently stored values (**RETRN**), to retain values stored in the temporary memory (**RTAIN**) or to reset all values to factory default settings (**RESET**). Press the ▲ and ▼ keys to select **RETRN**, **RTAIN** or **RESET**. To advance proceed as follows:

#### RETRN

To cancel any temporary changes to programmed values select **RETRN** and press the C key to return to the **SP400 MENU**.

#### RTAIN

To retain temporary changes to programmed values select **RTAIN** and press the C key to return to the **SP400 MENU**.

#### RESET

Provides the facility to reset all values to factory default settings and return to **SET UP NOW**. Press and hold the C key for 3 seconds. The display will count the 3 seconds.

### Commissioning notes

#### RETRN

If changes have been made to program values they will be held in the temporary memory. To retain changes in the permanent memory it is necessary to advance to **RUN** in the main menu and press and hold the C key for 3 seconds. The display will count the 3 seconds. **If you do not wish to retain temporary changes** select **RETRN** and press the C key to return to the **SP400 MENU**.

#### RTAIN

If changes have been made to programmed values they will be held in the temporary memory. If you wish to retain these changes select **RTAIN** and press the C key to return to the **SP400 MENU**. **To retain temporary changes in the permanent memory** advance to **RUN** in the main menu and press and hold the C key for 3 seconds. The display will count the 3 seconds.

#### RESET

Resetting to default values (refer to Section 9 for default values) should be used if it is intended to use the positioner on a different control valve. If the SP400 positioner has been moved on its mounting or is to be fitted on a different control valve it will be necessary to undertake a new autostroke (**AUTOS**).

**RESET** to factory default settings can also be used if it is required to recommission the valve.

**To reset to factory default values** select **RESET** and press and hold the C key for 3 seconds. The display will count the 3 seconds.

## 9.3 MANOP

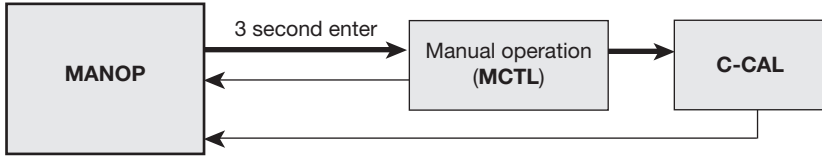


Fig. 31

### Programming notes

Press and hold the **C** key for 3 seconds to enter manual control mode (**MCTL**). The display will count the 3 seconds.

Press the **C** key to enter the current calibration mode (**C-CAL**). Press the **C** key to return to **MANOP**.

In **MANOP** press the **▼** key to advance to autostroke (**AUTOS**).

### Commissioning notes

Before initiating an autostroke commissioning (**AUTOS**) use manual control (**MCTL**) to manually fully inflate and deflate the actuator to ensure there are no obstructions to the full valve travel movement.

Manual control is also useful during normal operation to manually control the valve position as a commissioning aid or in the event of input signal failure.

### 9.3.1 MCTL - manual control

#### Programming notes

Manual control enables the actuator to be manually inflated or deflated. Press the **▲** key to inflate actuator and the **▼** key to deflate the actuator. Press and hold the **▲** or **▼** key to accelerate action.

Prior to undertaking an **AUTOS** the display will indicate **FILL** or **VENT**.

On completion of **AUTOS** the display will indicate % valve travel.

#### Manual control (MCTRL) - Tight shut-off function

Press and hold the **▼** key to drive the valve to its closed position. At 0% travel the **!** will flash to indicate limit of travel. To initiate tight shut-off release the **▼** key and press the **▼** again. The actuator will be vented of air to provide dead tight shut-off. This also applies to the 100% valve position by pressing and releasing the **▲** key and pressing the **▲** again to inflate the actuator to provide dead tight shut-off.

#### Manual control (MCTRL) - Travel limits

When operating in manual control any travel limit settings will be overridden therefore it is possible to manually position the valve through its full 0 to 100% travel as measured in autostroke (**AUTOS**).

### Commissioning notes

Before initiating an autostroke commissioning routine (**AUTOS**) the actuator should be manually fully inflated and deflated to ensure there are no obstructions to the full valve travel movement.

Manual control is also useful during normal operation to manually control the valve position as a commissioning aid or in the event of input signal failure.

---

### 9.3.2 C-CAL - current calibration

#### Programming notes

**C-Cal** provides a simple way to make a fine calibration of the input current signal (4 - 20 mA).

#### To perform the calibration:

1. Enter **C-CAL** and press the ▼ key, then press the **C** key.
2. Generate a **4 mA** input signal and press **C**
3. Generate a **12 mA** input signal and press **C**
4. Generate a **20 mA** input signal and press **C**

If '**ERROR**' is displayed the calibration routine is aborted. The value of the generated signal is too far from the expected one. Be sure that a 4 mA, 12 mA or 20 mA signal is generated as required. Press the **C** key to return to **C-CAL**.

If '**OK**' is displayed the calibration has succeeded. Press the **C** to return to **C-CAL**.

Where possible current calibration should be overtaken, to guarantee a perfect match between the input current generated and the reading of the SP400.

Let's assume that the table below show the input signal generated by a PLC or DCS versus the input signal read by the SP400.

Setpoint	Input current from PLC	Current read from SP400
0%	3.6 mA	3.8 mA
50%	12 mA	12.2 mA
100%	20 mA	20.2 mA

Hence when the setpoint is 0% the PLC generates a 3.6 mA instead of 4 mA.

After C-CAL is executed the SP400 recalibrates the current read to compensate the error.

Setpoint	Input current from PLC	Current read from SP400
0%	3.6 mA	4 mA
50%	12 mA	12 mA
100%	20 mA	20 mA

In this way a perfect match is achieved between the setpoint of the PLC and the setpoint of the of the SP400 (i.e. the input current read by the SP400).

## 9.4 AUTOS - automatic autostroke commissioning



Fig. 32

### Programming notes

**AUTOS** provides access to:

1. Autostroke commissioning (**AUTOS**).
2. % travel display (**TRAVL**).

### AUTOS

Autostroke provides an automatic commissioning routine which will take approximately 1 to 3 minutes to complete.

Press and hold the **C** key for 3 seconds to start autostroke. The display will count down the 3 seconds. When autostroke is active a flashing **AUTOS** message will be displayed.

On completion of a successful autostroke the programme will automatically return to **AUTOS** in the main menu and a ☺ will be displayed. In the event of an unsuccessful autostroke routine a flashing ! will be displayed.

If during **AUTOS** inconsistent data is obtained due to mechanical problems, the autostroke procedure will be terminated and **ABORT** will be displayed.

It is also possible to immediately abort during an autostroke routine by pressing the **C** key. **ABORT** will be displayed together with a flashing !.

#### Error messages:

**ERROR 1** Indicates a wrong mechanical coupling between positioner and actuator. Check the mounting is correct.

**ERROR 2** Indicates that there is insufficient air pressure to achieve valve movement. Check that the air supply is adequate to overcome the actuator spring force. Fitting of a gauge block will aid the commissioning procedure.

**ERROR 3** Indicates that the actuator will not deflate. Check that there is no obstruction preventing the stem travel or air venting from the actuator.

**ERROR 4** indicates that the stroke measured is less than the minimum stroke allowed - 10 mm for linear valves, and 5° for quarter turn valves (output 1 and output 2 for double action applications).

**ABORT** indicates mechanical problems have occurred during the Autostroke procedure or the **C** key has been pressed during Autostroke to abort the procedure.

On completion of a successful autostroke it will be possible to advance to **SET** and **RUN** functions in the main menu. Press the ▼ key to advance to these functions.

### Commissioning notes

Prior to undertaking an autostroke routine, manual operation should be used to fully inflate and deflate the actuator to ensure there are no obstructions to the full valve movement. Autostroke is an automatic commissioning routine that checks for maximum valve travel, signal response, valve characteristics, inflation/deflation times etc. Data gathered will be automatically download into the embedded software to ensure optimum performance of the valve/actuator combination.

Autostroke commissioning will take approximately 1 to 3 minutes to complete depending on air pressure and actuator size etc.

Autostroke commissioning must be carried out on start-up or at any other time if the valve performance is not satisfactory.

### 9.4.1 TRAVL - % travel display

#### Programming notes

Press the **C** key to access **TRAVL**.

Provides selection of % valve travel display with option of 0 - 100% or 100 - 0%.

Default is 0 - 100%.

Use the **▲** and **▼** keys to toggle selection.

Press the **C** key to return to **AUTOS**.

#### Commissioning notes

The selection of % valve travel display depends on the valve and actuator configuration. Figures 33 to 36, and Figures 37 and 38 (page 32) provide guidance on selection. After completion of **AUTOS** if a change is made to **TRAVL** it will be necessary to initiate an **AUTOS** routine once again.

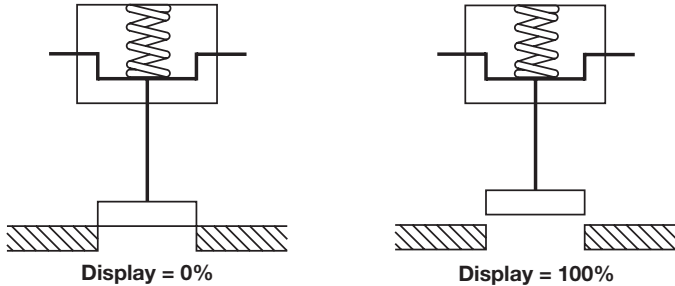


Fig. 33 2-port valve normally closed - TRAVL setting = 0 to 100%

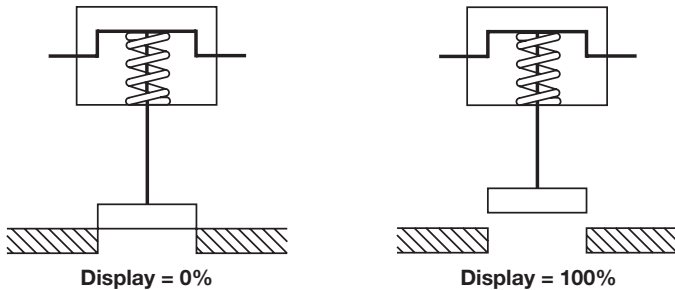
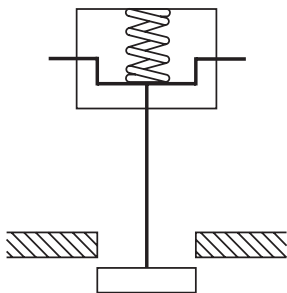
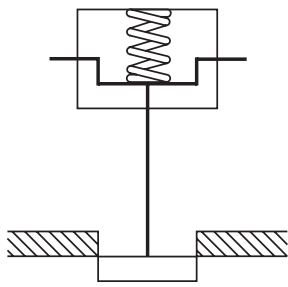


Fig. 34 2-port valve normally open - TRAVL setting = 0 to 100%

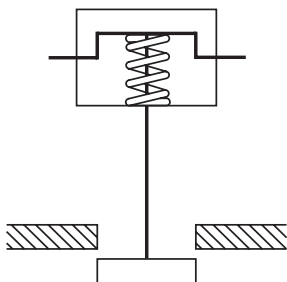


Display = 100%

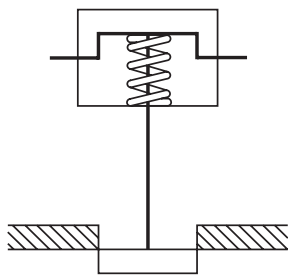


Display = 0%

Fig. 35 2-port valve normally open - TRAVL setting = 100% to 0%



Display = 100%



Display = 0%

Fig. 36 2-port valve normally closed - TRAVL setting = 100% to 0%

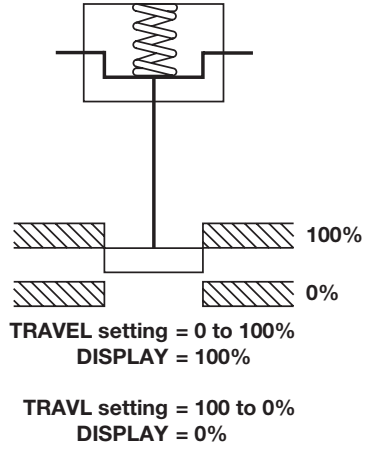
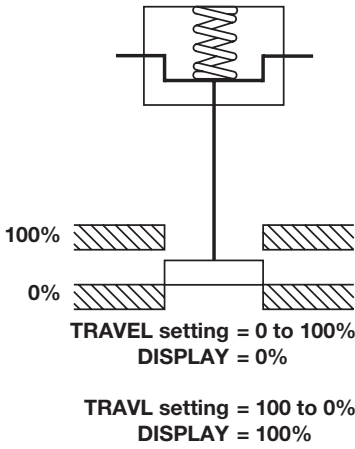


Fig. 37 3-port valve and spring extend actuator

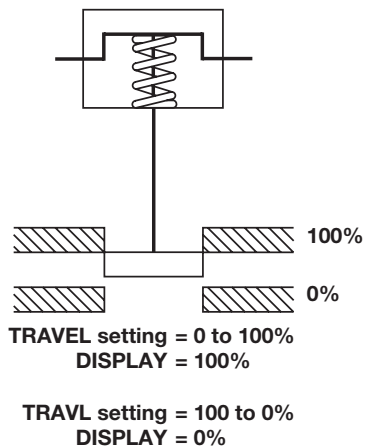
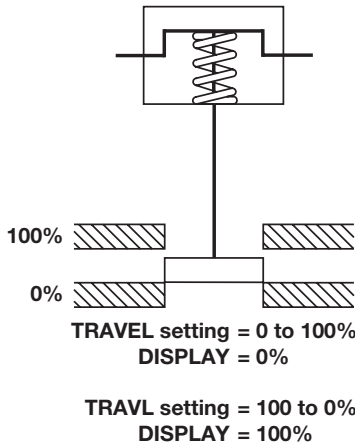


Fig. 38 3-port valve and spring retract actuator

## 9.5 SET - setting of valve functions

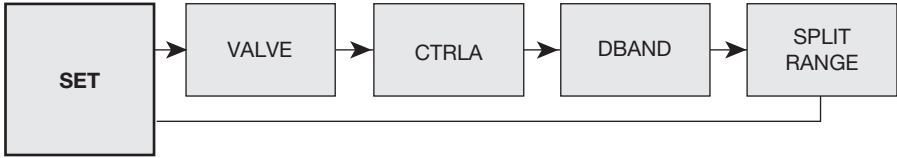


Fig. 39

### Programming notes

Provides access to basic valve set up functions. Press the **C** key to scroll round all **SET** functions.

#### Functions include:

- |                  |                                 |                      |
|------------------|---------------------------------|----------------------|
| - Valve type     | (2-port or 3-port)              | <b>(VALVE)</b>       |
| - Control action | (direct or reverse)             | <b>(CTRLA)</b>       |
| - Deadband       | (valve positioning sensitivity) | <b>(dBand)</b>       |
| - Split range    | (split range)                   | <b>(SPLIT RANGE)</b> |

Press the **C** key to advance to valve type (**VALVE**). Repeat pressing of the **C** key will scroll round all **SET** functions.

Press the **▼** key to advance to **TUNE** in the main menu.

### Commissioning notes

Each **SET** function has a default value as listed in the Installation and Maintenance Instructions. Default values are based on a 2-port normally closed valve having maximum 95% lift and an input signal span range 4 - 20 mA.

**SET** values should be adjusted to suit the valve type (2-port or 3-port) and application. Functions include the facility to change the control action, limit the full travel of the valve plug (minimum and maximum) and to split range the input signal.

More detailed information is provided for each **SET** function.

---

## 9.5.1 VALVE - valve type

### Programming notes

#### 2-port

On 2-port valves when the setpoint is 100%, the positioner will open to 95% of the stroke and display 100%, to prevent the back of the plug hitting the bonnet. Tight shut-off is set to 1% on 'vent' operation.

#### 3-port

On 3-port valves tight shut-off is set to 1% on 'vent' and 'fill' operations to ensure shut-off on both seats. When setpoint is 100%, the positioner will open to 100% of the stroke and display 100%.

Use the ▲ and ▼ keys to select type. Press the C key to accept displayed type and advance to control action (**CTRLA**).

---

## 9.5.2 CTRLA - direct or reverse control action

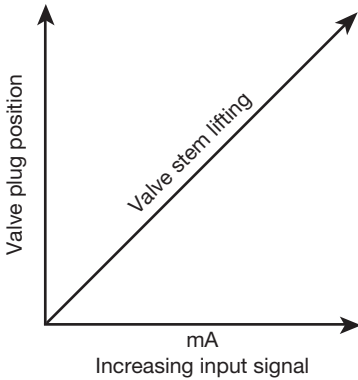
### Programming notes

Provides selection of direct (**DIRCT**) (4 - 20 mA) or reversed (**REV**) (20 - 4 mA) valve positioning control action. Press the ▲ and ▼ keys to select desired action. Default action is **DIRCT**.

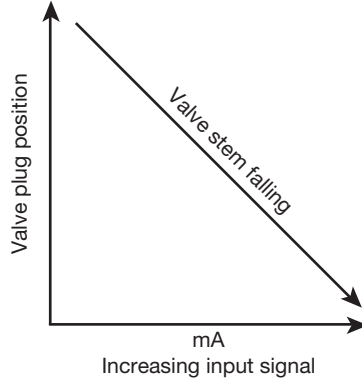
Press the **C** key to accept the displayed action and advance to deadband (**DBAND**).

### Commissioning notes

Selection of direct or reverse action changes the direct of valve plug movement relative to the input signal. Refer to Figures 40 and 41 for further guidance.

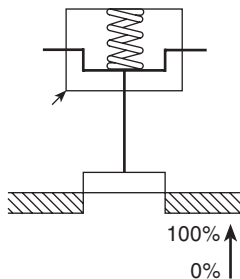
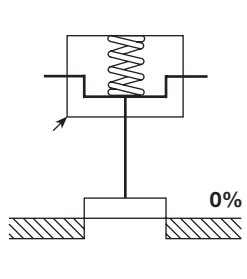
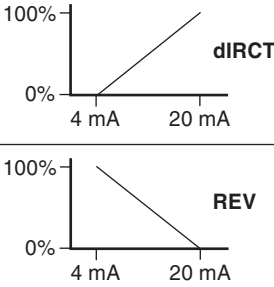
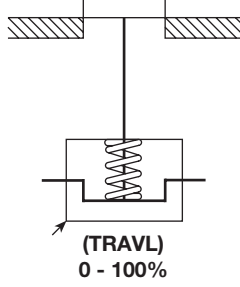
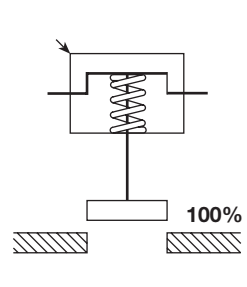
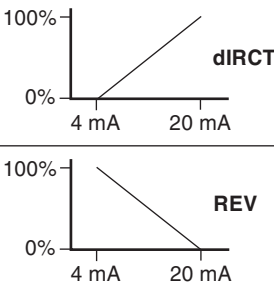
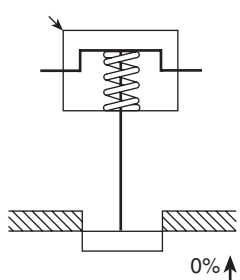
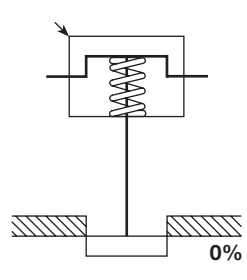
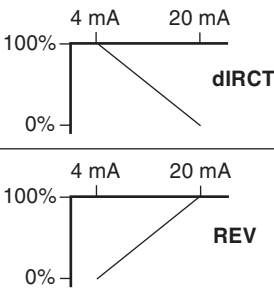
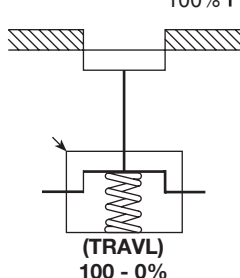
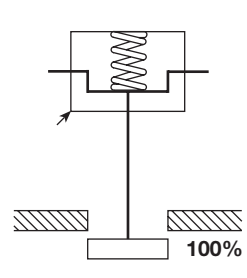
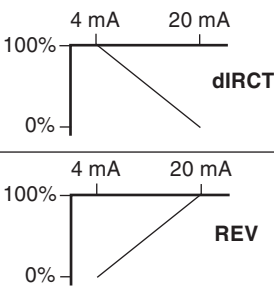


**Fig. 40 Direct action (DIR)**



**Fig. 41 Reverse action (REV)**

**Fig. 42 CTRL Control Action dIRCT or REV setting guidance**

Installed orientation	At-rest position	Control action
		
 <p>(TRAVL) 0 - 100%</p>		
		
 <p>(TRAVL) 100 - 0%</p>		
<p>Manual Selection of required % travel (TRAVL)</p>	<p>Automatic determination Spring action only affects the rest or fail-safe position</p>	<p>Manual Selection of required Control Action (CTRLA)</p>

---

### 9.5.3 dbAND - deadband setting (positional sensitivity)

#### Programming notes

Dead-band provides adjustment of the valve positioning sensitivity relative to the input signal and is expressed as a % of the input signal span.

Default value based on a 4 - 20 mA input signal span is 0.5%. To alter the displayed value press the ▲ and ▼ keys. Press the C key to accept the displayed value and advance to split range.

#### Commissioning notes

Setting a narrow deadband may induce oscillations of valve movement caused by fluctuations in the input signal, high stem friction or operating at low ambient temperatures below 0°C. Setting a wider deadband will dampen out oscillations but may cause an inaccuracy in actual valve position. This effect will increase if valve travel is limited. It is normally recommended that the default value is used. If necessary increase the % value to dampen out any oscillations in valve movement. This may be necessary for valves having graphite packed stem seals or smaller size actuators.

### 9.5.4 Split range

This menu can change the range. 3 values are allowed: **OFF**, **LOW** and **HIGH**.

**OFF** (range: 4-20 mA)

4 mA corresponds to the minimum of the stroke 0%

20 mA corresponds to the maximum of the stroke 100%

**LOW** (range: 4-13 mA)

4 mA corresponds to the minimum of the stroke 0%

13 mA corresponds to the maximum of the stroke 100%

**HIGH** (range: 11-20 mA)

11 mA corresponds to the minimum of the stroke 0%

20 mA corresponds to the maximum of the stroke 100%

To alter the displayed value press the ▲ and ▼ keys. Press the C key to accept the displayed value and return to SET.

#### Commissioning notes

This function is used when 2 positioners are on the same current loop. One set to LOW, the other set to HIGH. When the current rises beyond 11 mA, the second valve starts to open giving its contribution to the overall flow. A single current signal drives 2 valves.

---

## 9.6 RUN - automatic operation

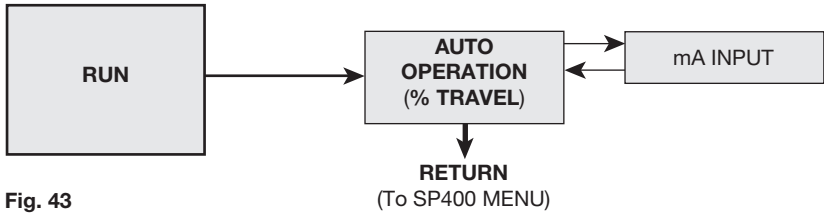


Fig. 43

### Programming notes

Provides the facility to put the valve into automatic operation. Press and hold the **C** key for 3 seconds to start automatic operation. The display will count the 3 seconds.

The valve will move to a position in response to the input control signal. All values stored in the temporary memory will be transferred to the permanent memory.

### Commissioning notes

By pressing and holding the **C** key for 3 seconds all values previously set will be entered into the permanent memory. The valve will move to a position as dictated by the input control signal.

To alter or check **SET** or **TUNE** values it is necessary to return to the **SP400 MENU**. Press and hold the **C** key for 3 seconds to return to the **SP400 MENU**. The display will count the 3 seconds. The positioner will vent the actuator and the valve will travel to its fail safe position.

---

## 9.6.1 Automatic operation - % travel

### Programming notes

During normal automatic operation the % valve travel will be continuously displayed. Additionally, a 😊 will be displayed indicating that the valve is operating satisfactorily. At any time during automatic operation the mA input signal can be displayed by pressing the ⏏ key.

To return to the **SP400 MENU** press and hold the ⏏ key for 3 seconds.

### Commissioning notes

During normal operation the % valve travel will be continually displayed. A 😊 indicates that the valve is performing satisfactorily. Causes of fluctuations in valve movement can be related to input signal. Press the ⏏ key to view actual mA input signal.

## 9.6.2 Input signal - mA signal display

### Programming notes

The mA input signal will be displayed. Press the ⏏ key to return to displaying % travel. The programme will automatically return to displaying % travel after 5 minutes.

### Commissioning notes

This function is of assistance to visualise and check input signal relative to valve position and to investigate causes of fluctuations in valve movement. The mA input signal will be displayed for 5 minutes. Press the ⏏ key to return to displaying % travel. The programme will automatically return to displaying % travel after 5 minutes.

## 10.1 Air supply quality

It is important for correct operation of the SP400 positioner that good quality air is supplied.

It is therefore recommended that a Spirax Sarco MPC2 filter regulator or equivalent is fitted on the air supply to the positioner. In addition the SP400 positioner has an internal filter. In normal operation it is recommended that this filter is replaced every 6 to 12 months depending on the air quality and valve usage. A spare filter plug kit can be obtained from Spirax Sarco that includes: filter plug, plus 3 off 'O' rings and filter.

## 10.2 Fitting replacement filter plug kit

**To change the filter proceed as follows:**

- Ensure that the air supply to the positioner is isolated.
- Unscrew the filter plug (1) from the SP400 housing using a 5 mm hex. head socket key (refer to Figure 65).

**The replacement filter plug can now be fitted:**

- Fit the 'O' ring (4) and filter (3) onto the filter plug (1) (refer to Figure 49).
- Finally fit the retaining screw (2).

The filter plug can now be replaced into the SP400 housing, checking that the 'O' ring (4) is correctly located.

The pneumatic air supply can now be restored to the positioner and checks made to ensure that the filter plug 'O' ring has provided the necessary air tight seal.



Fig. 44

Filter plug (1)

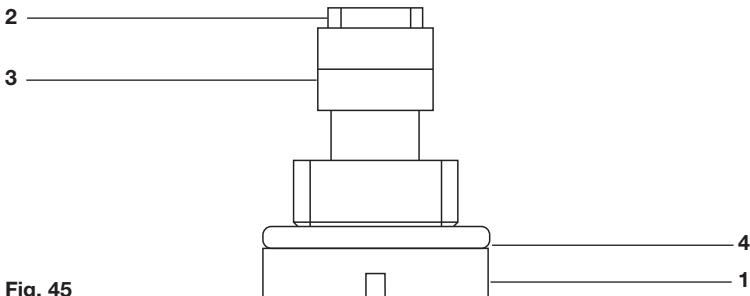


Fig. 45

# 11. Default values and program settings

Main menu	Sub-menu	Setting options	Default value	Programmed value
<b>SET</b>	Valve type <b>(VALVE)</b>	<b>2-PORT</b> <b>3-PORT</b>	<b>(2-PORT)</b>	
<b>SET</b>	Control action <b>(CTRLA)</b>	Direct ( <b>dIRECT</b> ) Reverse ( <b>REV</b> )	<b>(dIRECT)</b>	
<b>SET</b>	Deadband <b>(dBAND)</b>	0.5%, 1.5%, 3.0%, 5.0%	0.5%	
<b>SET</b>	Split range <b>(SPLIT)</b>	OFF (range 4-20 mA) LOW (range 4-13 mA) HIGH (range 11-20 mA)	OFF	

# 12. Glossary of display data

## 12.1 Main menu display functions

Display	Description
<b>SET UP NOW</b>	Indicates that the SP400 positioner fitted to the valve has not been programmed or commissioned.
<b>SP400 MENU</b>	Indicates that you have now entered the SP400 main menu. <b>Provides access to:</b> <ul style="list-style-type: none"><li>• View the version of the embedded software.</li><li>• Retain temporary changes to menu values (<b>RETRN</b>).</li><li>• Recall previously stored menu values (<b>RTAIN</b>).</li><li>• Reset to default values (<b>RESET</b>).</li></ul>
<b>MAN OP</b>	Provides access to manual control ( <b>MCTL</b> ) and current calibration ( <b>C-CAL</b> ).
<b>AUTOS</b>	<b>Provides access to:</b> <ul style="list-style-type: none"><li>• Autostroke commissioning routine.</li></ul> <b>Note: SET and RUN functions can only be accessed after a successful AUTOSTROKE routine has been completed.</b> <ul style="list-style-type: none"><li>• Selection of percentage travel display % (<b>TRAVL</b>).</li></ul>
<b>SET</b>	<b>Provides access to valve set up functions as follows:</b> <ul style="list-style-type: none"><li>• Valve type (<b>VALVE</b>).</li><li>• Control action (<b>CTRLA</b>).</li><li>• Deadband (<b>dBAND</b>).</li><li>• Split range (<b>SPLIT</b>).</li></ul>
<b>RUN</b>	<b>Provides access to:</b> <ul style="list-style-type: none"><li>• Commencing automatic operation.</li><li>• Displaying percentage valve travel (%).</li><li>• Visualisation of input mA input signal (<b>mA</b>).</li><li>• Total stem strokes (<b>STRVL</b>).</li><li>• Total running time (<b>RTIME</b>).</li><li>• Return to SP400 menu (<b>RETRN</b>).</li></ul>

## 12.2 Sub-menu display functions

Display	Description
<b>VER x.xx</b>	Indicates the version of software embedded within the SP400 positioner.
<b>PSWRD</b>	Permits the upgrade from SP400 to SP500.
<b>RETRN</b>	Enables previously stored function values to be recalled.
<b>RTAIN</b>	Enables temporary changes made to function values to be retained.
<b>RESET</b>	Enables all function values to be reset to default settings. Refer to Section 11 for default settings.
<b>MCTL</b>	Provides manual control of the valve. Use the ▲ and ▼ keys to fill or vent the actuator.
<b>C-CAL</b>	Calibration of the current input.
<b>TRAVL</b>	Selection of percentage of travel display - 0 to 100% or 100 to 0% depending on valve and actuator configuration.
<b>AUTOS</b>	Initiates the autostroke automatic commissioning routine.
<b>AbORT</b>	Indicates that the <b>AUTOS</b> commissioning routine has been aborted.
<b>VALVE</b>	Selection of 2-port or 3-port valve.
<b>CTRLA</b>	Selection of input signal control action 4 - 20 mA or 20 - 4 mA.
<b>dBAND</b>	Selection of deadband.
<b>SPLIT</b>	Selection of the range, used with 2 positioner in the same loop.
<b>%</b>	Indicates percentage of valve travel in automatic operation or manual control ( <b>MCTL</b> ).
<b>mA</b>	Indicates the input signal in mA.
<b>FILL</b>	Indicates the actuator is being filled with air (manual control before <b>AUTOS</b> ).
☺	Indicates that there are no problems with the positioner.
!	An error or warning indication.
<b>ERROR 1 (AUTOS)</b>	Indicates a problem with the mounting position.
<b>ERROR 2 (AUTOS)</b>	Indicates that there is insufficient air pressure to position the valve.
<b>ERROR 3 (AUTOS)</b>	Indicates that the air cannot be vented from the actuator.
<b>ERROR 4 (AUTOS)</b>	Detected stroke too short.

