

### M10S Ball Valve Screwed, SW, BW and Flanged Versions

#### Installation and Maintenance Instructions

The Spirax Sarco M10S and M10S ISO ball valves are a three piece design comprises of:  
Body and two end caps.

**M10S**  
Screwed and Flanged versions shown.

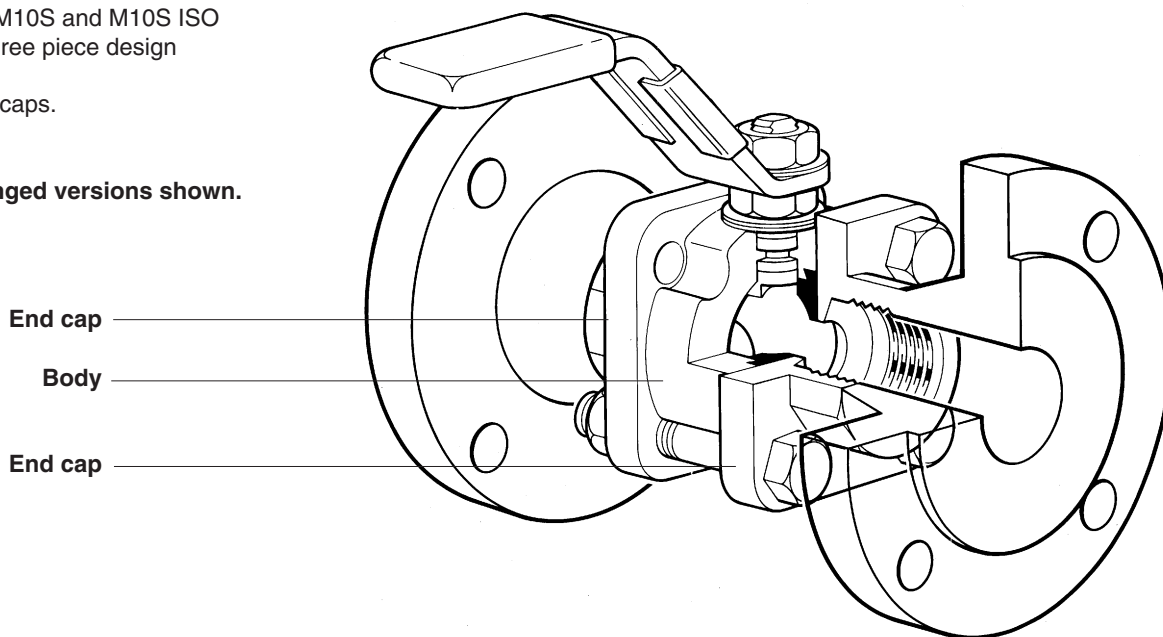

#### Installation

Although the valve has great structural integrity, severe misalignment and / or the pulling effect of incorrect pipe length will have a detrimental effect on the valve and must be avoided.

Particular attention should be paid to correct pipe alignment such that the inlet pipework and valve are all on the same axis.

Valves are for on/off applications and may be installed with flow in either direction. When used on steam services:

1. Fit a trapped drain pocket upstream of the valve.
2. Open valve slowly to prevent the risk of waterhammer damage.

#### Socket and butt weld valves

Prior to any welding it will be necessary to:

1. Dismantle the end caps from the body.
2. Remove the R-PTFE seats.
3. Weld each end cap to the pipeline.
4. Replace the R-PTFE seats.
5. Reassemble.

#### Safety note

Before commencing any dismantling work ensure that no flow is taking place in the pipeline; that the line is isolated elsewhere, or that the flow of the fluid is discontinued. Any fluid remaining in the line should be drained off before dismantling the valve.

---

## Maintenance

### General

Maintenance work can be carried out without removing the complete ball valve from the pipeline. Remove the two upper bolts and nuts (15, 16) and loosen the lower two. The complete body assembly can then be removed and any new parts fitted.

### Flanged valves

To proceed with maintenance work, the complete flanged valve requires removal from the pipeline. Remove the 4 nuts (16), the complete body assembly can now be removed and new parts fitted.

### To replace seats

1. Remove the body as described above.
2. With body removed, remove seats (5).
3. Fit new seats, pushing them into body recesses.

### To replace stem seals

1. Remove body as described above.
2. Remove nuts (11), (9) and the belleville washers (8).
3. Replace stem seals (6).

### Reassembly

Reassemble in reverse order to instructions given above. The secure bolts and nuts (15, 16) should be tightened to the torques shown in te table opposite.

## Spare parts

The spare parts available are shown in heavy outline. Parts drawn in broken line are not supplied as spares.

### Available spare

Seat and stem seal set	5, 6
------------------------	------

### How to order spares

Always order spares by using the description given in the column headed Available Spare and stating the size and type of ball valve required.

**Example:** 1 - Seat and stem seal set for 1/2" M10S2FB ball valve.

### M10S version shown.

\*M10S ISO version has an additional stem seal positioned as indicated on the diagram by the \*.

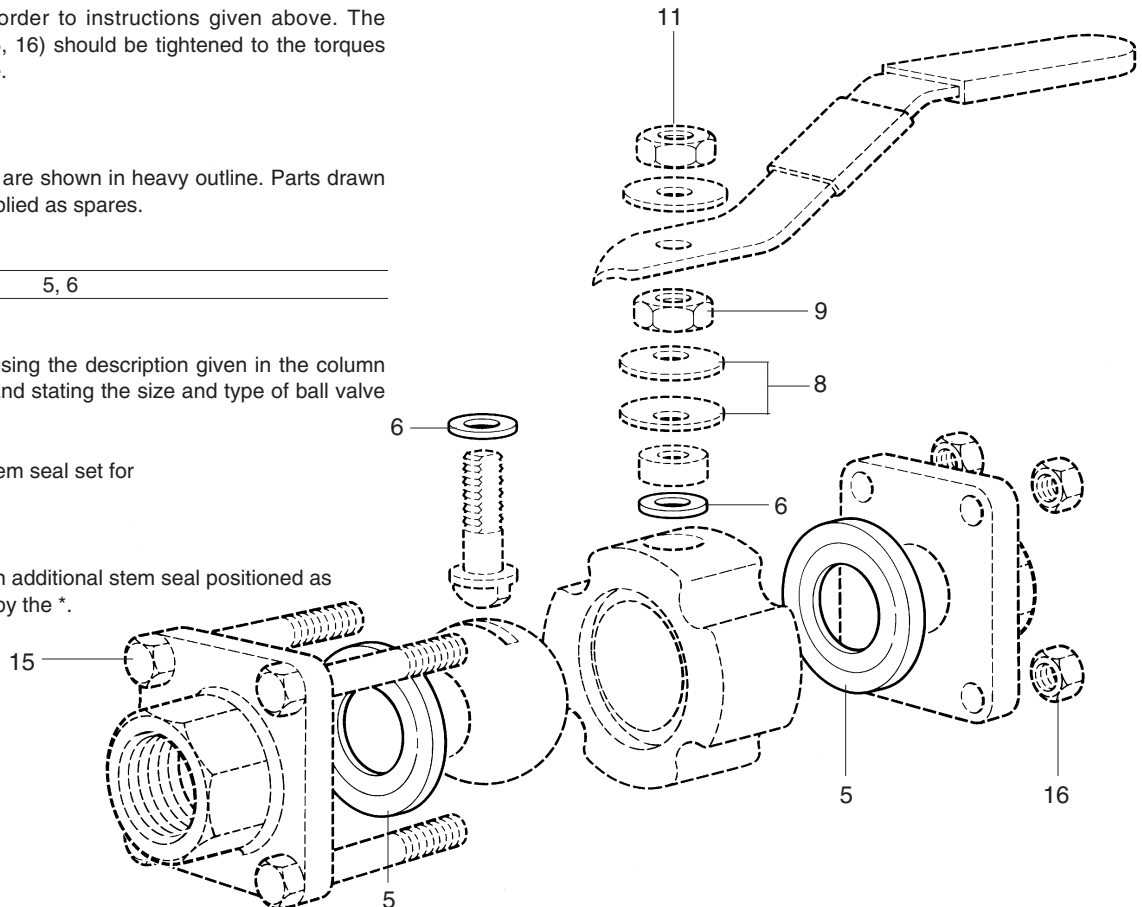

## Recommended tightening torques

### Securing bolts and nuts

Item	Size	in-lbs
15 and 16	1/4", 3/8", 1/2" RB	115
	1/2" FB, 3/4" RB	115
	3/4" FB, 1" RB	265
	1" FB, 1-1/4" RB	265
	1-1/4" FB, 1-1/2" RB	350
	1-1/2" FB, 2" RB	500
	2" FB, 2-1/2" RB	660
Stem nut		
Item	Size	in-lbs
9	1/4", 3/8" RB	36/48
	1/2", 3/4" RB	48/72
	3/4" FB, 1" RB	95/120
	1" FB, 1-1/4" RB	155/180
	1-1/4" FB, 1-1/2" RB	155/180
	1-1/2" FB, 2" RB	300/350
	2" FB, 2-1/2" RB	350/415

Spirax Sarco Applications Engineering Department

Toll Free at: 1-800-833-3246

**spirax**  
**/sarco**®

SPIRAX SARCO, INC. • 1150 NORTHPOINT BLVD. • BLYTHEWOOD, SC 29016  
PHONE 803-714-2000 • FAX 803-714-2222 • WWW.SPIRAXSARCO.COM/US