

Inspect the float for damage, and replace if necessary. A collapsed float is evidence of extremely severe and dangerous waterhammer conditions which must be rectified before the trap is returned to service.

Ensure that all traces of the old mechanism gasket are removed and that the gasket seating surfaces are clean and undamaged. Install the new or cleaned mechanism assembly, using a new gasket and a little jointing paste. Tighten the mechanism cap screws to a torque of 50-55 ft•lb (68-75 Nm).

All traces of the old gasket must be removed from the body and cover, and the gasket seating surfaces must be clean and undamaged. Fit a new gasket, applying a thin coating of jointing paste. To assist in locating the gasket and cover, bolts at the four corners may be temporarily threaded from the underside of the body flange. Install and tighten the cover bolts (with lockwashers) to a torque of 250-275 ft•lb (339-373 Nm).

The strainer ahead of the trap must be serviced as required to ensure the screen is unobstructed.

The trap may be returned to service by slowly opening the isolating valves (the downstream valve should be opened first).

Troubleshooting

Like any other double-seated valve, the FA450 main valve may leak very slightly in the closed position. In the extremely unlikely event that the liquid load drops below the residual leakage rate (approximately 0.4% of full load), the valve may pass a very small amount of gas. This will happen only in very unusual circumstances.

Spare Parts

	Part No.	Stock No.
Valve Mechanism Kit	D,E,F	66365
Gasket Kit (pkt of 3 each)	B,F	66796
Float Kit	P	66798

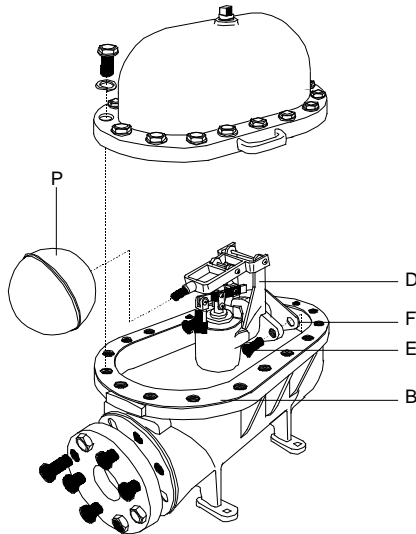

For additional technical information, contact Spirax Sarco Applications Engineering Department
Toll Free 1-800-833-3246

**spirax
sarco**

Spirax Sarco, Inc. • 1150 Northpoint Blvd. • Blythewood, SC 29016
Phone 803-714-2000 • Fax 803-714-2200

**spirax
sarco**

INSTALLATION AND MAINTENANCE INSTRUCTIONS

IMI 7.3151

March 2002

Steel Liquid Drain Trap

3" and 4" FA450

Description and Operation

The Spirax Sarco 3" and 4" FA450 is a high capacity Liquid Drain trap. The float adjusts the position of the double seated main valve so that liquid is discharged continuously at the same rate as it enters the trap. To prevent gas binding and allow liquid to flow freely into the trap, a pressure balancing pipe must be connected between the trap and the space to be drained. A 3/4" tapping is provided for this purpose.

The FA450 will operate against any back pressure lower than the inlet pressure. (The differential pressure - inlet pressure minus outlet pressure - determines the trap's capacity.)

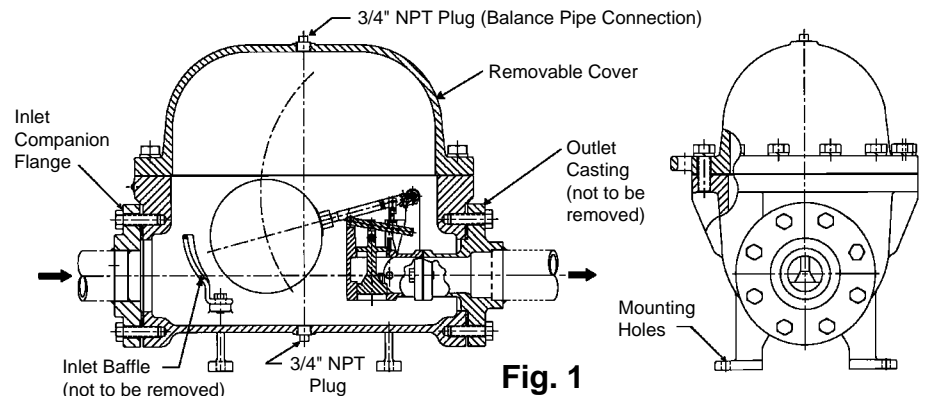

Fig. 1

Limiting Operating Conditions

FT450

Standard Configuration

Maximum Operating Pressure (PMO)	450 psig (31 barg) *
Maximum Operating Temperature	650°F at 450 psig (343°C at 31 barg) 750°F (400°C) at operating pressures below 375 psig (26 barg)
Cold Hydraulic Test Pressure	675 psig (46 barg)

PED Compliant Configuration

Maximum Operating Pressure (PMO)	30 barg
Maximum Operating Temperature	343°C @ 30 barg 400°C @ 26 barg
Maximum Allowable Pressure (PMA)	30 barg @ 343°C 29 barg @ 371°C 26 barg @ 400°C
Maximum Cold Hydraulic Test Pressure	73 barg

* For liquids with a specific gravity less than 0.75, the PMO will be reduced. See TIS 7.318

Dimensions (nominal)

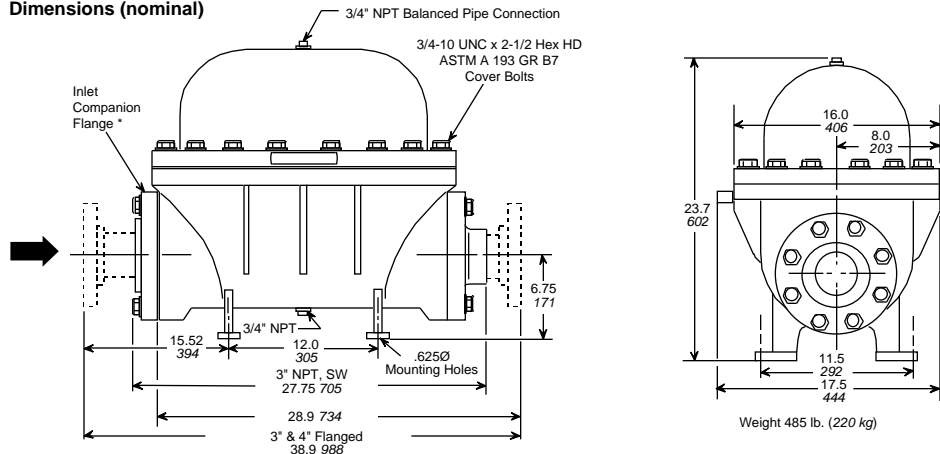

* The inlet connection on NPT or SW traps is a standard 4" ANSI 300 RF Flange bolted to the trap body. The flange bore is 3", NPT or SW to match the outlet connection of the trap.

Fig. 2

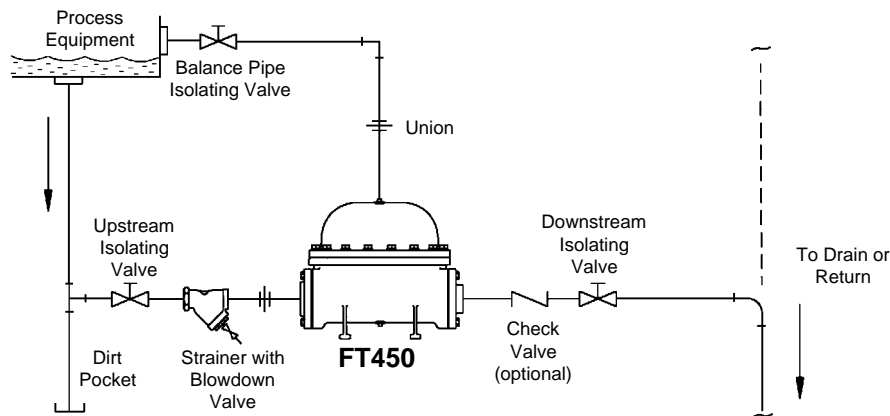

Fig. 3

Liquid drain traps can be used to drain most liquids from most gases. However, some applications, particularly those involving hazardous or unusual fluids, may be subject to regulation or may otherwise require special consideration. Spirax Sarco will endeavor to provide whatever data is necessary to assist in product selection.

Installation

Before installing the trap, the inlet piping should be carefully blown down to remove any existing pipe debris.

Caution: Before installation, inspection or maintenance, the trap must be completely isolated from both supply and return line pressure.

The trap must be supported firmly in a horizontal position. The four feet are drilled 5/8"Ø to accept 1/2" mounting bolts. The total weight of the trap partially filled with liquid is approximately 550 lb (250 kg). Observe the "in" and "out" markings on the body.

The trap should be positioned with the inlet no higher than, or preferably below, the equipment drain point. If possible, a drop leg and dirt pocket should be provided ahead of the trap.

A pipeline strainer should be installed ahead of the trap, and full-flow isolating valves should be located to permit servicing. A check valve after the trap is recommended to prevent backflow.

A pressure-balancing pipe (preferably 3/4") must be installed between the tapping on the top of the trap and the space to be drained. If a pipeline or separator is being drained, the balance pipe connection should be downstream of the drainage point. For process equipment, the balance pipe connection must be above the maximum liquid level.

Access above the trap must be provided for servicing. (The cover weighs approximately 150 lb [68 kg]). Bypass piping is not recommended because of the possibility of misuse. If a bypass is installed, it should be at least one size smaller than the trap line size, and the bypass valve must be capable of tight shut off.

NPT and SW traps are shipped with a companion flange bolted to the inlet. This flange can be welded (or threaded) to the inlet piping.

The trap is supplied with a flanged, NPT or SW outlet connection as required. **The bolted outlet casting is not a flange, and must not be removed.**

When placing the trap in service, no priming is necessary. The inlet isolating valve must be opened slowly to prevent damage to the trap and piping system. It is recommended that the equipment, piping and trap be slowly raised to operating conditions.

Maintenance and Repair

This trap can be serviced without disturbing the piping connections.

Caution: The trap must be isolated from both supply and return line pressure before any servicing or disassembly. Pressure which may be present in the trap after the isolating valves are closed must be relieved before the trap is opened. This can be accomplished by opening the blowdown valve on the strainer ahead of the trap.

Do not attempt to remove the bolted outlet casting.

Remove and save the cover bolts and lockwashers. Lift the cover from the body.

Remove the bottom plug to drain the liquid remaining in the body.

Using a suitable solvent, remove all dirt and incrustation from the mechanism, body and cover. Inspect the body and cover for corrosion or damage.

The main valve mechanism assembly is secured to the body by two cap screws. Remove the mechanism and gasket, and inspect the valve linkage and pins for signs of wear or damage. Ensure that the pins are properly secured by the retaining washers. Inspect the valve heads and seats for damage, wear or wire drawing. If any of the valve mechanism parts are worn or damaged, it is recommended that the entire assembly be replaced.