

Stainless Steel Filter CSF26

About the CSF26

The CSF26 is an in-line all 316 stainless steel filter with 2.8 micron absolute rated element suitable for steam, liquid and gas service.

In order to avoid possible damage during shipping, the CSF26 body and element are packed in separate boxes.

Limiting Operating Conditions

Max. Operating Pressure (PMO)
150 psig/10.3 barg

Max. Operating Temperature (TMO)
366°F/186°C

Pressure Shell Design Conditions
(PMA) Max. Allowable Pressure
275 psig/0-100°F 19 barg/0-38°C

(TMA) Max. Allowable Temperature
750°F/0-95 psig 399°C/0-6.5 barg

Element Design Conditions
Max. Element Differential Pressure 15 psi/1 bar

Installation

In steam service

1. When used in steam service, the CSF26 should be installed as in the Fig. 1 hook-up. This hook-up is in accordance with 3-A Accepted Practice Number 609-01 which covers the production of culinary steam.
The separator and strainer shown will remove residual condensate and larger solid particles, such as rust and pipscale prior to filtration. This will increase filter efficiency and prolong element life.
2. The filter body (1) should be installed with the filter bowl (2) vertically up, and the flow arrow pointing in the direction of steam flow.
3. A steam trap should be fitted to the filter body (1) to remove residual condensate which will form during operation, or when the filter is isolated.
4. An air vent (Spirax Sarco MST18) should be fitted to the filter bowl (2) to ensure maximum filter efficiency.
5. Pressure gauges should be fitted upstream and downstream of the filter to indicate filter element condition. To avoid re-contamination of the system, all downstream pipe and fittings should be stainless steel.

In gas service

1. A separator and strainer should be installed upstream of the CSF26.
2. Pressure gauges should be fitted upstream and downstream of the filter to indicate filter element condition. To avoid re-contamination of the system, all downstream pipe and fittings should be stainless steel.

In liquid service

1. The plug in the filter bowl (2) should be removed, and fitted in the lower filter body drain connection.
2. An automatic air vent should be installed on the filter bowl.
3. Pressure gauges should be fitted upstream and downstream of the filter to indicate filter element condition. To avoid re-contamination of the system, all downstream pipe and fittings should be stainless steel.

Note: Before commissioning the CSF26, the 1/4" NPT plastic drain plug on the body needs to be removed and a steam trap or other suitable plug installed.

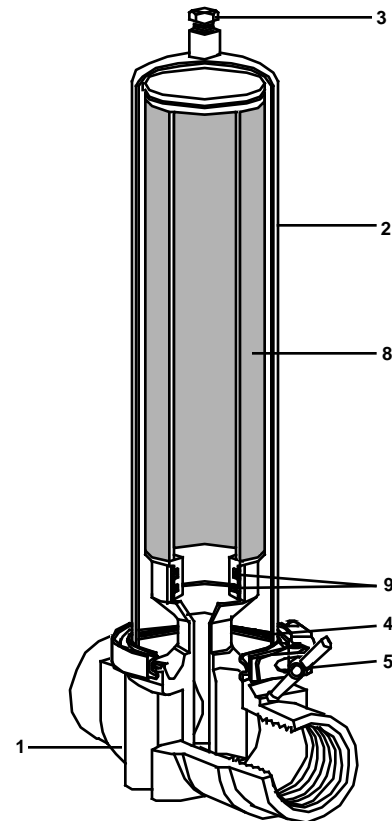

Removing and Fitting the filter element

1. Loosen and remove the body clamp (5) (1/2" - 2-1/2" CSF26). Remove body bolts (3"CSF26).
2. Remove filter bowl (2).
3. Remove element (8).

Reassembling and Fitting the filter element

1. Lubricate element O-Rings (9) with petroleum gel or silicone oil as approved for the application.
2. Gently push element (8) into filter body (1).
3. Re-fit filter bowl (2) and body clamp(5)/body bolts.
4. Hand tighten clamp (5) (1/2" - 2-1/2"CSF26). Tighten body bolts (3" CSF26) to 20-25 lb-ft, 27-34 Nm.

Note: It is recommended that the body O-Ring (4) be replaced each time an element is cleaned or renewed.

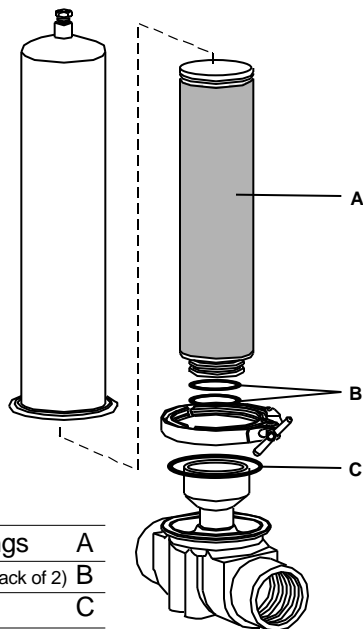

Spare Parts

Filter Element with O-Rings	A
Filter Element O-Rings (Pack of 2)	B
Body O-Rings (Pack of 2)	C

Element Cleaning

It is recommended that the CSF26 element be removed for cleaning or replacement when the differential pressure across the unit reaches 10 - 15 psi.

Upon removal from the filter body, contaminants on the surface of the element such as rust, will begin to corrode, potentially damaging the element media. It is therefore important to clean a contaminated element promptly upon removal from the filter

The element can be cleaned chemically or in an ultrasonic bath as outlined below:

Chemical cleaning

1. Remove O-Rings (9)
2. Immerse the element (8) slowly in a solution of 17% by weight: sodium hydroxide (chlorine free), 3% by weight: sodium carbonate, 80% water. Boil for one hour. (Do not flow through element as caustic particles may be removed from the cleansing fluid and clog filter medium.)
- Caution:** Safety controls for hazardous solutions are necessary. Bath container must be able to safely accommodate hot caustic solution. Protective clothing, hand, eye and face equipment is required as recommended by the chemical supply company.
3. Rinse element with water to remove alkali.
4. Soak element in hot (200°F) 14% nitric acid for 10 minutes. Nitric acid, 14%, is made by adding 1 part concentrated acid to 4 parts water.
5. Wash element in cold water. If water is unfiltered, do not force water through element as fine particulate matter in water will partially clog the porous media.
6. Air dry at a temperature not to exceed 230°F.
7. Install new O-Rings.

Ultrasonic cleaning

Elements can be cleaned ultrasonically, using cleaning agents compatible with the element material. Prior to cleaning, the element O-Rings should be removed. New O-Rings should always be installed once an element has been cleaned. It is recommended that the manufacturer of the ultrasonic equipment be contacted to establish an appropriate cleaning routine.

Fig. 1

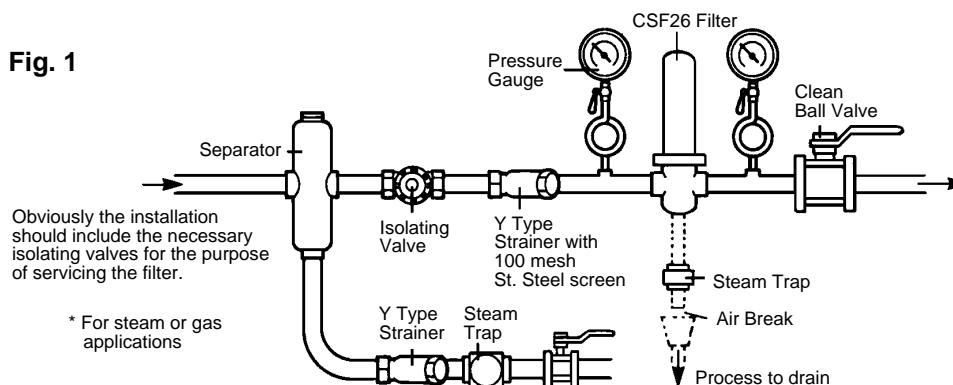

For any additional information you may require, contact: Spirax Sarco Applications Engineering Department
Toll Free 1-800-833-3246

spirax
sarco®