

Stainless Steel Sanitary Pressure Regulator SRV6

Description

The Spirax Sarco SRV6 is an angle pattern, sanitary pressure regulator with polished 316/316L stainless steel construction for use on clean steam, process liquids and gases.

NOTE: The SRV6 should **not** be used for line isolation. If line isolation is required, a Model 61 Ball Valve should be installed upstream of the SRV6.

Maximum Operating Conditions

Maximum Operating Pressure: 116 psig, 8.0 bar

Maximum Operating Temperature: 347°F, 175°C

Downstream Control Range: 7-75 psi

Installation (Refer to Fig. 1)

1. The SRV6 should be installed with the inlet vertical and the spring chamber upward for fully self draining operation.
2. For steam applications, a steam trap should be installed at the bottom of the vertical riser into the SRV6 to prevent build-up of condensate. Alternatively, a separator with trap should be installed immediately upstream of the SRV6.
3. Piping on the downstream side of the regulator should be increased to prevent restriction of flow.
4. Clean ball valves such as the Spirax Sarco Model 61 should be used both upstream and downstream to enable the regulator to be isolated for maintenance.
5. Before installing the valve, make sure the piping is free of foreign material, scale, etc.
6. To permit accurate setting of the regulator and to aid trouble shooting, pressure gauges should be installed both upstream and downstream.
7. In order to adequately protect downstream equipment, a safety valve or bursting disc may be required.

Start-Up & Operation

1. First make sure that all stop valves are closed.
2. Check that adjusting screw (1) is slack. If necessary, turn counter-clockwise to release tension.
3. Open stop valves in the following order:
 - a. Open stop valve upstream of steam trap on inlet side of the regulator.
 - b. Open downstream stop valve.
 - c. **CAUTION: OPEN INLET STOP VALVE SLOWLY TO AVOID DAMAGE FROM WATERHAMMER.**
4. Slowly adjust screw (1) by turning clockwise until required reduced pressure is indicated downstream of the regulator.
5. Once the system has stabilized, it may be necessary to re-adjust the regulator. Tighten lock nut (2).
6. When not in use, isolate the valve upstream of the SRV6.

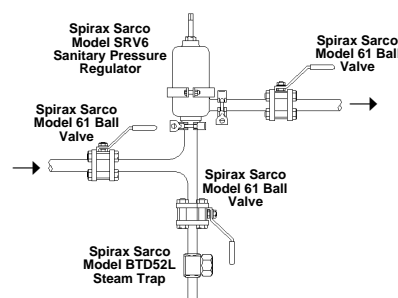

Fig. 1 Recommended installation-steam service

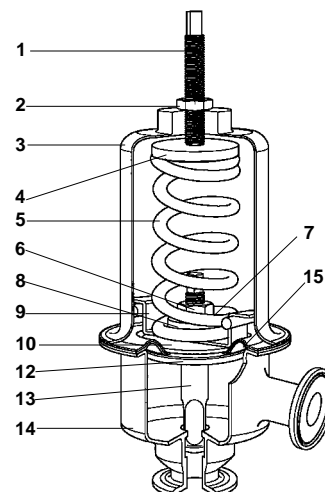

Fig. 2

General Maintenance

While a program of planned maintenance is always to be recommended, the Spirax Sarco SRV6 regulator will give long and trouble-free service if correctly selected, installed and kept reasonably free of particulate matter. Dirt and foreign matter are most likely to collect during installation and later trouble can be avoided by inspecting the pipeline before installation. After a few days operation, check all joints for leakage.

Inspection/Repair (Refer to Fig. 2)

1. Shut isolating valves upstream and downstream and allow valve to cool.
2. Remove regulator from the pipeline.
3. Release spring tension by turning adjusting screw (1) fully counter-clockwise after first slackening lock nut (2).
4. Remove V-band clamp.
5. Firmly hold edge of diaphragm (15) and body (14) and rotate spring chamber (3) through 90° (see Fig. 3). The arrow on the lower edge of the spring chamber can be used as a guide.
6. Remove spring chamber (3).
7. Remove spring pusher (4) and spring (5).
8. Holding flat section at top of main valve (13) with a wrench, remove diaphragm nut (6) and spring washer (7).
- 9.* Remove spacer ring (8), retainer (9), upper disc (10), diaphragm (15), and lower disc (12).
10. The main valve (13) can be removed through the regulator inlet.
11. Inspect valve head and seat. Re-lap or replace main valve (13) if necessary.
12. Inspect diaphragm (15) for wear and replace if necessary.
13. Re-assemble in reverse order noting in particular:
 - a. Lower disc (12) has chamfered edge on the central hole to allow a seal to be made with the diaphragm (15) and main valve (13). ENSURE THAT UPPER (10) AND LOWER DISCS (12) ARE NOT TRANSPOSED, AND THAT BOTH ARE INSTALLED WITH ROUNDED EDGE FACING DIAPHRAGM.
 - b. When spring chamber is replaced, line up arrow so that it is directly in front of one of the legs of the retainer (9) - see Fig. 3. Firmly hold diaphragm edge (15) and body (14) and rotate spring chamber (3) through 90°. This locks the diaphragm restraint in place and will prevent over-extension.
 - c. Ensure that the diaphragm is accurately centered before refitting the V-band clamp. Tighten clamp to a torque of 75 lbin.

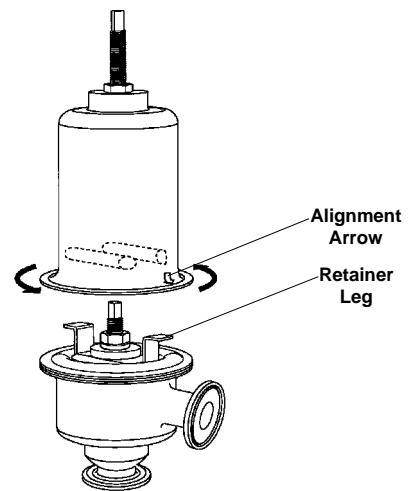

Fig. 3

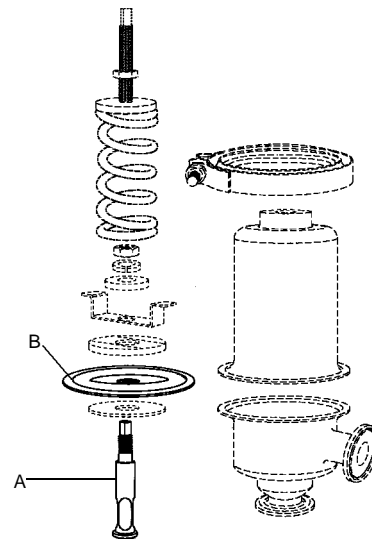

Fig. 4 Available Spares

Spare Parts

Available spare parts are shown in Fig. 4. Always order spares using the descriptions given, together with the valve type and size.

AVAILABLE SPARES

Main Valve	A
Diaphragm	B

* Valves marked with dual range (circa 5/94) may have upper discs (10) and lower discs (12) measuring 1.75" in diameter. To accommodate the current diaphragm design, the discs should measure 1.25" in diameter. Replacement discs for valves that use the 1.75" diameter discs are available by contacting the factory.

Spirax Sarco Applications Engineering Department
Toll Free at: 1-800-833-3246

SPIRAX SARCO, INC. • 1150 NORTHPOINT BLVD. • BLYTHEWOOD, SC 29016
PHONE 803-714-2000 • FAX 803-714-2200