

25 Series Main Valve Rebuild Kit

Parts List

Item	Description	Quantity
B	Bolts	4
C	Gasket Cap	1
L	Diaphragm	2
M	Screen	1
O	Valve Spring	1
P	Type 25 Valve Head	1
Q	Type 25 Valve Seat	1
R	Seat Gasket	1
U,V	Transmission Tubing	1
W	Pilot Gasket	3

1/2"-2"

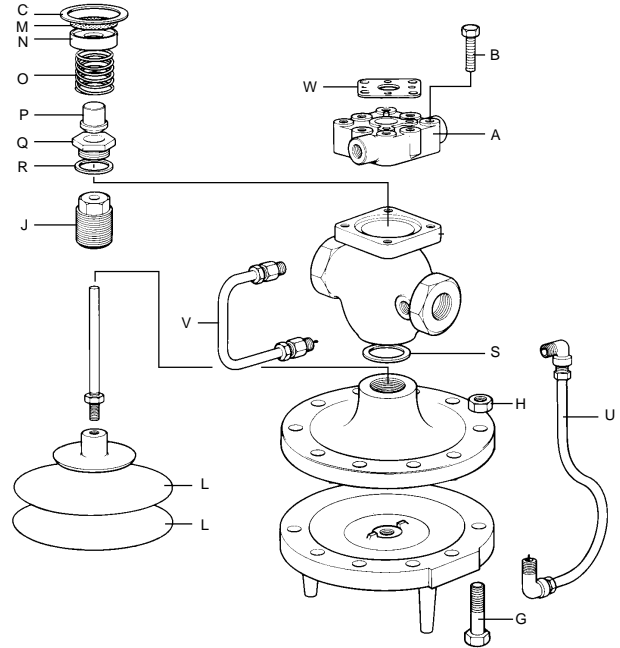

2-1/2"-4"

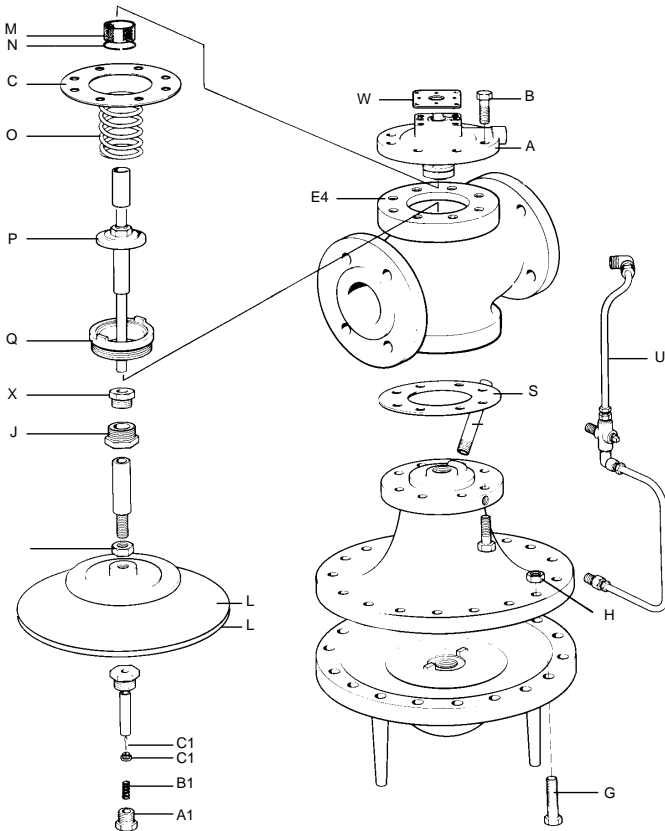

6"

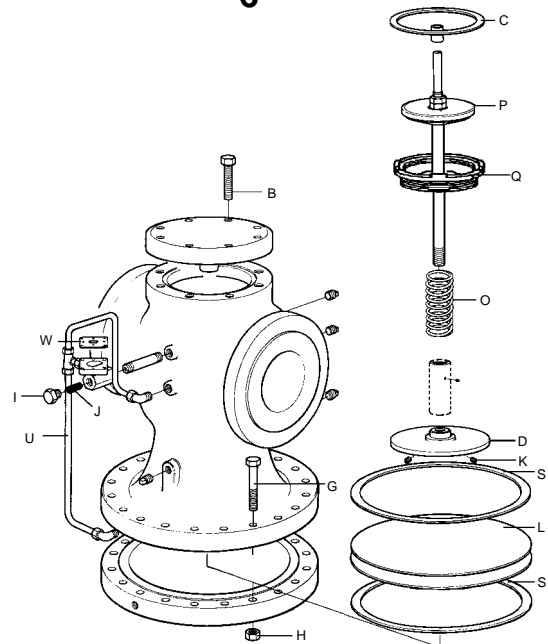

Valve Sizes 1/2" thru 4"

Inspecting and Replacing Main Valve Head and Seat (Refer to Figs. 3 and 5).

1. Unscrew copper tubings at (J) and (L).
2. Disconnect pressure control line at the pressure pilot connection.
3. Remove main valve cover cap screws (1A).
4. Remove main valve cover, strainer, screen, and head spring.
5. Head can then be removed by simply withdrawing with a pliers or similar tool.
6. Inspection should then be made to determine if scale or other foreign material prevented tight closure of the head and seat.
7. If the head or seat shows signs of wear, this can be corrected by grinding, using a fine grinding compound (400 grit) providing the wear is not too severe. Check for body erosion.
8. If it is necessary to replace the valve seat, this can be removed from the valve body using a standard hexagon socket. (Valve sizes 1/2" to 2"). When replacing the valve seat, a new gasket should be used to insure a tight joint. 2-1/2" thru 6" valves contain raised lugs for removal and seal metal-to-metal without a gasket. Replacement heads and seats should be lapped in.

Valve Sizes 1/2" thru 4"

Inspecting and Replacing Main Valve Diaphragms (Refer to Figs. 3, 4 and 5).

1. Unscrew copper tubing connection at (G).
2. Remove main valve diaphragm bolts (1C).
3. This will allow the lower diaphragm case to be removed.
4. The 2 metal diaphragms (1H) should be inspected to insure that they have not become distorted or possibly fractured as a result of abnormal operating conditions.
5. At the same time, any accumulation of dirt or foreign material should be removed from the diaphragm case.
6. The valve stem (1F) should also be checked to make sure it is free to move and that there is no scale or foreign material lodged in the guide bushing.
7. **Before reassembling diaphragms in 1/2" thru 4" sizes, main valve head must be in place and held in a closed position with the return spring and main valve cover.**
8. Make certain pressure plate (1G) is set properly. (Refer to Fig. 4).
9. Care should be taken in centering the diaphragms properly and equalizing bolt take-up uniformly.

6" Valve Only

Inspecting and Replacing Main Valve Diaphragms, Seat, and Head Assembly

(Refer to Fig. 7)

Diaphragms

1. Unscrew copper tubing connections (G) to lower diaphragm chamber.
2. Remove main valve diaphragm bolts (1C) and drop lower diaphragm case.
3. The 2 metal diaphragms (1H) should be inspected and replaced if they have become distorted or fractured.
4. Clean any accumulation of dirt from the diaphragm case and ori-

For any additional information you may require, contact:
Spirax Sarco Applications Engineering Department
Toll Free 1-800-833-3246



SPIRAX SARCO, INC. • 1150 NORTHPOINT BLVD. • BLYTHEWOOD, SC 29016
PHONE 803-714-2000 • FAX 803-714-2200