



Cert. No. LRQ 0963008

ISO 9001

# spirax sarco

## FT14 and FT14HC SG Iron

### Ball Float Steam Traps (1" HC, 1¼", 1½" and 2")

FT14HC  
1"

FT14  
1¼"

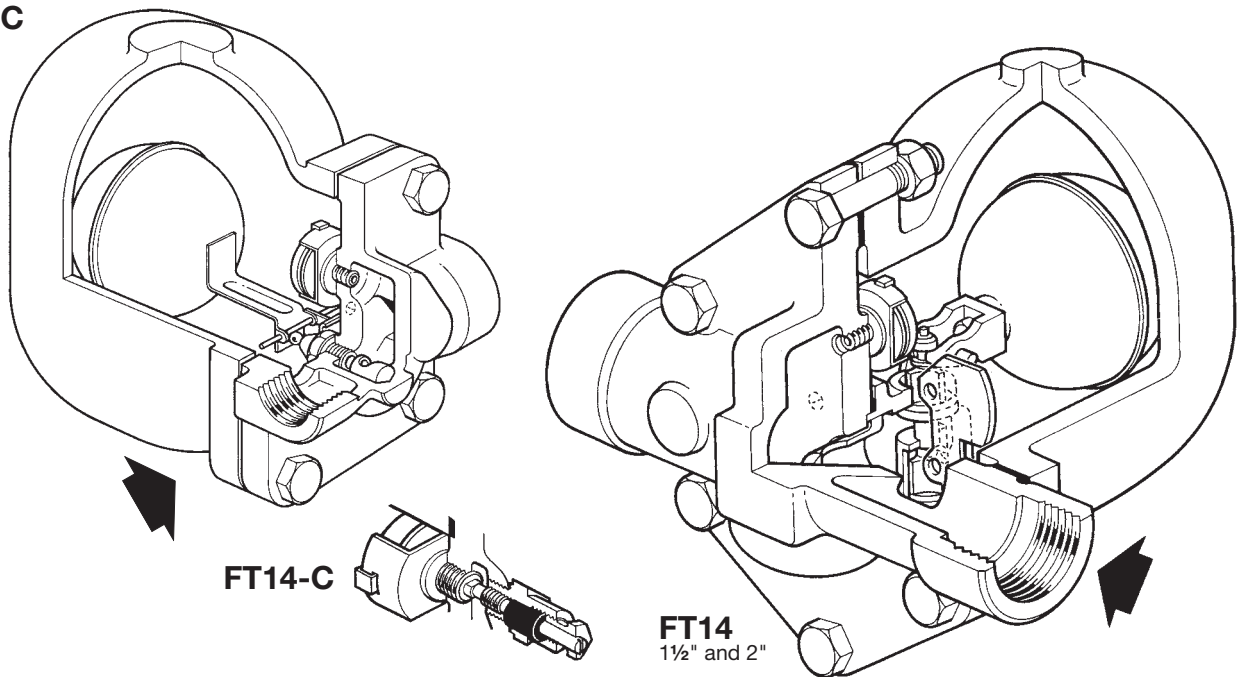

FT14-C

FT14  
1½" and 2"

#### Description

The FT14 and FT14HC are iron bodied ball float steam traps having stainless steel working internals and integral automatic air venting facility. These traps are supplied with horizontal screwed connections only and can be maintained without disturbing the pipework. The flow direction is as indicated on the valve body.

#### Available types

**FT14** Standard 1¼", 1½" and 2"

**FT14HC** High capacity (1" only) - As standard the FT14HC is available with flow direction in either left-to-right or right-to-left direction. Please state preference when placing an order.

**Note:** These ball float steam traps are available with either 4.5, 10 or 14 bar internals ( $\Delta PMX$ ).

#### Capsule

The BP99/32 capsule which is used in the FT14 and FT14HC ball float steam traps is suitable for use on 150°C superheat @ 0 bar g and 50°C superheat @ 32 bar g.

**Optional extras** will only be supplied if specified at the point of order

A **manually adjustable needle valve** (designated 'C' on the nomenclature i.e. **FT14-C**) can be fitted to the trap. This option provides a **steam lock release (SLR)** feature in addition to the standard air vent. For further information please consult Spirax Sarco.

The **top of the cover can be drilled and tapped up to 3/8" BSP or NPT** for the purpose of fitting a balance line.

The **bottom of the cover can be drilled and tapped 3/8" BSP or NPT** for the purpose of fitting a drain cock.

#### Standards

This product fully complies with the requirements of the European Pressure Equipment Directive 97/23/EC.

#### Certification

This product is available with a manufacturers' Typical Test Report. **Note:** All certification/inspection requirements must be stated at the time of order placement.

**Sizes and pipe connections** 1" (FT14HC only), 1¼", 1½" and 2" screwed BSP and NPT.

**Pressure / temperature limits** See page 2 for the pressure/temperature limitations.

**Materials** See page 3 for the materials list.

**Capacities** See page 4 for full capacity details.

Local regulations may restrict the use of this product to below the conditions quoted.

In the interests of development and improvement of the product, we reserve the right to change the specification without notice.

© Copyright 2009

**Pressure / temperature limits**

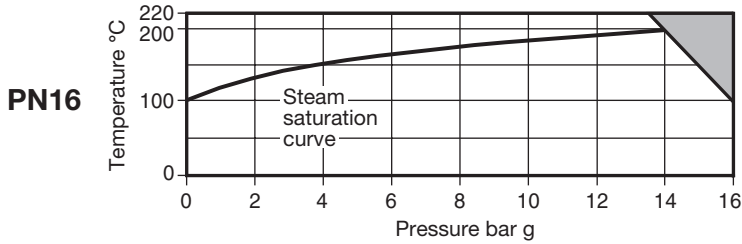
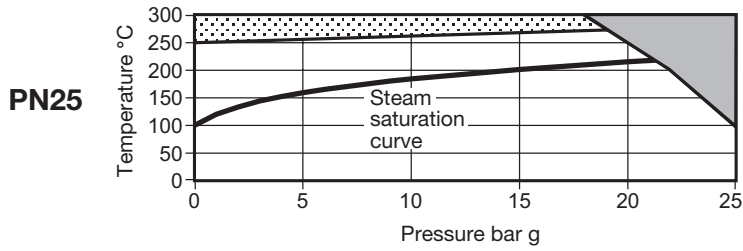

 The product **must not** be used in this region.

 The product should not be used in this region as damage to the internals may occur.

Size	1" HC and 1 1/4"	1 1/2" and 2"
Body design conditions	PN25	PN16
PMA Maximum allowable pressure	25 bar g @ 100°C	16 bar g @ 100°C
TMA Maximum allowable temperature	300°C @ 18 bar g	220°C @ 13.5 bar g
Minimum allowable temperature	-10°C	-10°C
PMO Maximum operating pressure for saturated steam service	21 bar g	14 bar g
TMO Maximum operating temperature	275°C @ 19 bar g	220°C @ 13.5 bar g
Minimum operating temperature	0°C	0°C
<b>Note:</b> For lower temperatures consult Spirax Sarco		
	<b>Size</b>	<b>1" HC</b> <b>1 1/4"</b> <b>1 1/2" and 2"</b>
ΔPMX Maximum differential pressure	<b>4.5 bar</b>	FT14HC-4.5      FT14-4.5      FT14-4.5
	<b>10 bar</b>	FT14HC-10      FT14-10      FT14-10
	<b>14 bar</b>	FT14HC-14      FT14-14      FT14-14
Designed for a maximum cold hydraulic test pressure of:	38 bar g	24 bar g

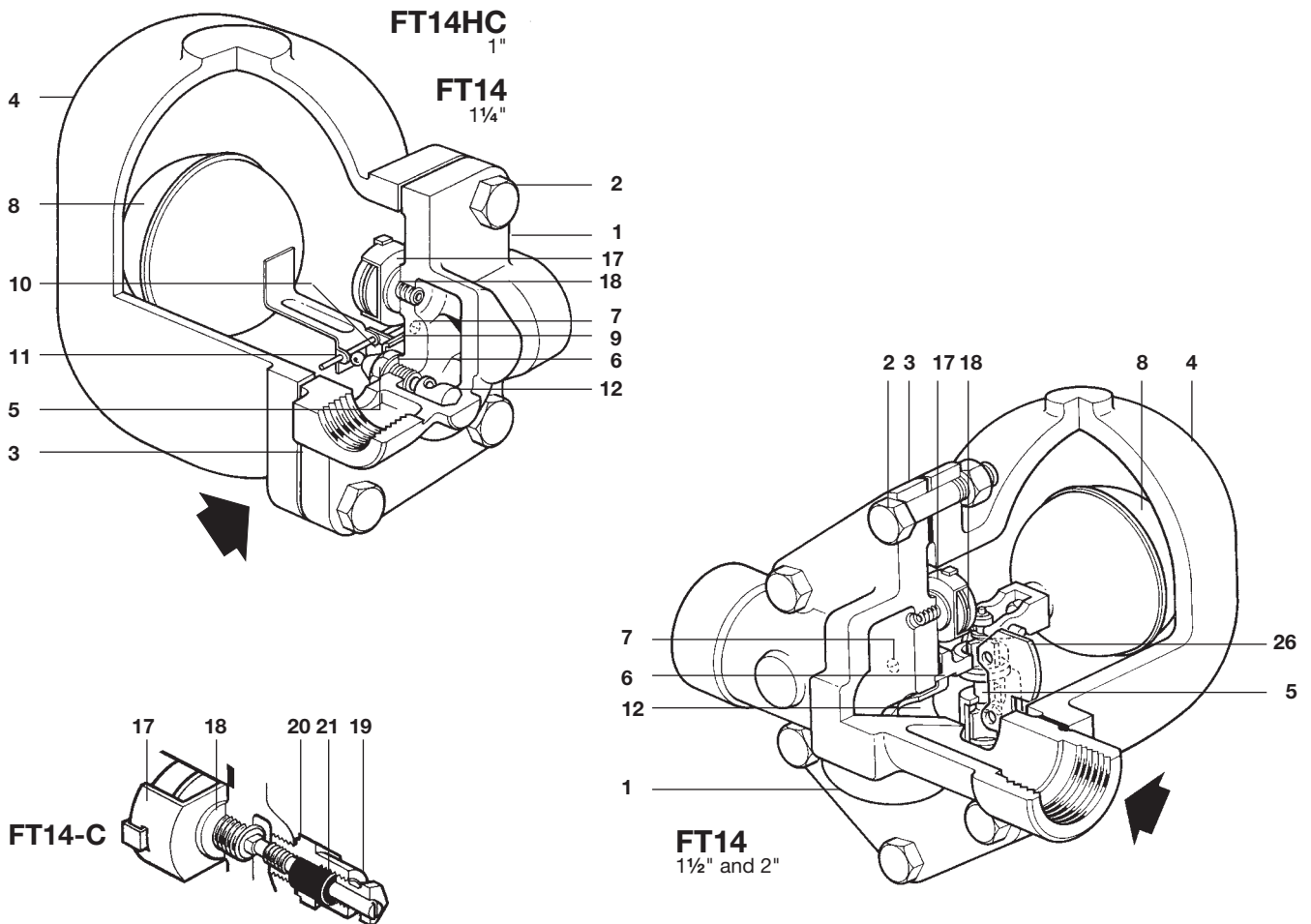

## Materials

No.	Part		Material	
1	Body	1" and 1 1/4"	SG iron	BS EN 1563 JS 1030
		1 1/2" and 2"	Cast iron	DIN 1691 GG 25
	Cover bolts	1"	Steel	BS 3692 Gr. 8.8
2	Cover bolts	1 1/4"	Steel	ASTM A193 B7
		Cover bolts & nuts	1 1/2" and 2"	Steel
3	Cover gasket		Reinforced exfoliated graphite	
4	Cover	1" and 1 1/4"	SG iron	BS EN 1563 JS 1030
		1 1/2" and 2"	Cast iron	DIN 1961 GG 25
	Valve seat	1" and 1 1/4"	Stainless steel	BS 970 431 S29
5	Main valve assembly with erosion deflector	1 1/2" and 2"	Stainless steel	BS 3146 Part 2 ANC 2
6	Main valve assembly gasket	1" and 1 1/4"	Stainless steel	BS 1449 304 S11
		1 1/2" and 2"	Reinforced exfoliated graphite	
	Pivot frame assembly set screws	1" and 1 1/4"	Stainless steel	BS 4183 18/8
7	Main valve assembly bolts	Bolts 1 1/2"	Stainless steel	ISO 3506-2: A2-70
		Studs and nuts 2"	Stainless steel	BS 6105 A4-80
8	Ball float and lever		Stainless steel	BS 1449 304 S16
9	Support frame	1" and 1 1/4"	Stainless steel	BS 1449 304 S16
10	Pivot frame	1" and 1 1/4"	Stainless steel	BS 1449 304 S16
11	Pivot pin	1" and 1 1/4"	Stainless steel	
12	Erosion deflector		Stainless steel	BS 970 431 S29
17	Air vent assembly		Stainless steel	
18	Air vent seat gasket		Stainless steel	BS 1449 304 S11
19	SLR assembly		Stainless steel	BS 970 303 S21
20	SLR gasket		Mild steel	BS 1449 CS4
21	SLR seal		Graphite	
26	Inlet plate	1 1/2" and 2" only	Stainless steel	BS 1449 304 S16

# Capacities

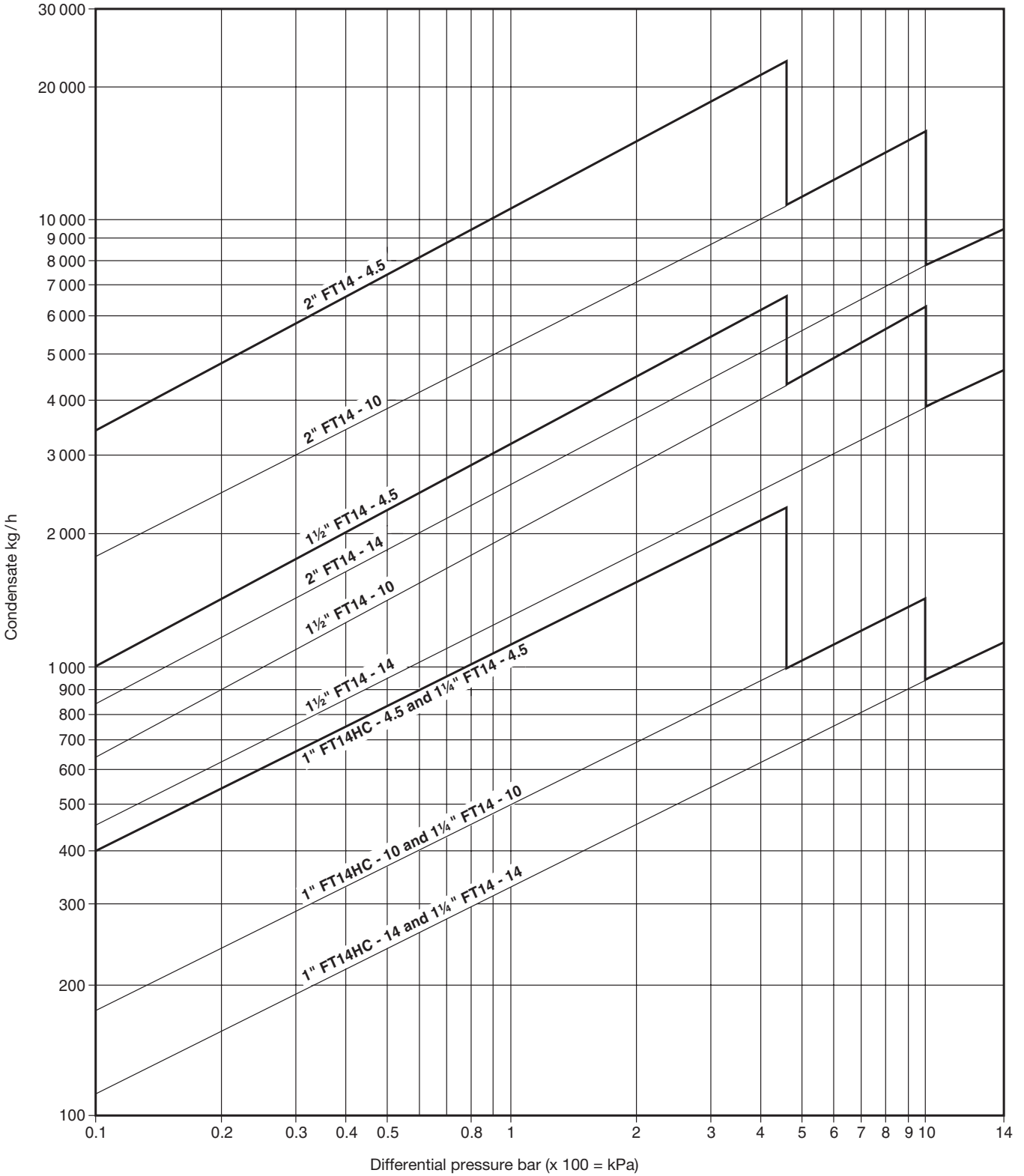

## Additional cold water capacities from the thermostatic air vent under start-up conditions

Capacities shown above are based on condensate at saturation temperature. Under start-up conditions when the condensate is cold the internal thermostatic air vent will be open and provides additional capacity to the main valve. The following table gives the minimum additional cold water capacities from the air vent.

$\Delta P$ (bar)	0.5	1	2	3	4.5	7	10	14
	<b>Minimum additional cold water capacity (kg/h)</b>							
1" HC	580	600	650	670	700	1000	1300	1600
1 1/4, 1 1/2" and 2"	580	600	650	670	700	1000	1300	1600

**Dimensions / weights (approximate) in mm and kg**

Size	A	B	C	D	E	F	G	Weight
1" HC	120	110	80	195	160	220	115	6.8
1¼"	120	110	80	195	160	220	115	6.9
1½"	270	130	108	248	200	270	115	17.5
2"	300	138	125	250	200	288	140	22.0

1½" and 2" shown

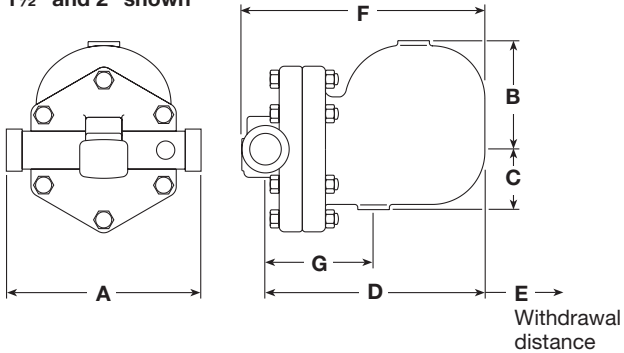

**Safety information, installation and maintenance**

For full details see the Installation and Maintenance Instructions (IM-S02-30) supplied with the product.

**Installation note:**

The FT14 must be installed with the direction of flow as indicated on the body, and with the float arm in a horizontal plane so that it rises and falls vertically.

**Disposal**

This product is recyclable. No ecological hazard is anticipated with the disposal of this product providing due care is taken.

**How to order**

**Example:** 1 off Spirax Sarco 1" screwed BSP FT14HC-14 ball float steam trap having an SG iron body and cover, with thermostatic air vent - flow direction left-to-right. The cover is to be suitable for tapping ¾" for drain/balance pipe connection.

**Spare parts**

The spare parts available are shown in solid outlines. Parts drawn in broken lines are not supplied as spares.

**Available spares**

Main valve assembly	with float (1" and 1¼")	<b>5, 6, 7, 8, 9, 10, 11</b>
	with erosion deflector (1½" and 2")	<b>5, 6, 7, 26</b>
Ball float (1½" and 2")		<b>8</b>
Air vent assembly		<b>17, 18</b>
Manually adjustable needle valve (SLR) and air vent assembly		<b>17, 18, 19, 20, 21</b>
Complete set of gaskets (packet of 3 sets)		<b>3, 6, 18, 20</b>



**Note:** The erosion deflector on the 1" and 1¼" is pressed into the body during manufacture and is not available as a spare.

**How to order spares**

Always order spares by using the description given in the column headed 'Available spares' and state the size and type of trap.

**Example:** 1 - Air vent assembly for a Spirax Sarco 2" FT14-4.5 ball float steam trap.

**Recommended tightening torques**

Item	Size	 or 	mm	N m
2	1"	17	M10 x 30	29-33
	1¼"	14*	M10 x 30	29-33
	1½"	19	M12 x 60	60-66
	2"	24	M16 x 70	80-88
5	1" and 1¼"	17	-	40-45
	1" and 1¼"	-	M5 x 20	10-12
7	1½"	10	M6 x 20	10-12
	2"	13	M8 x 20	20-24
17	-	17	-	50-55
19	-	21	-	40-45

\*Note: Reduced A/F bolt head required

**Steam lock release assembly**

