



Cert. No. LRQ 0963008

ISO 9001

# spirax sarco

TI-S02-22  
ST Issue 6

FT43

Cast Iron

## Ball Float Steam Traps DN80 and DN100

### Sizes and pipe connections

DN80 and DN100

Standard flange: EN 1092 PN16.

Flanges available on request: JIS 10, KS 10 and ASME (ANSI) 125

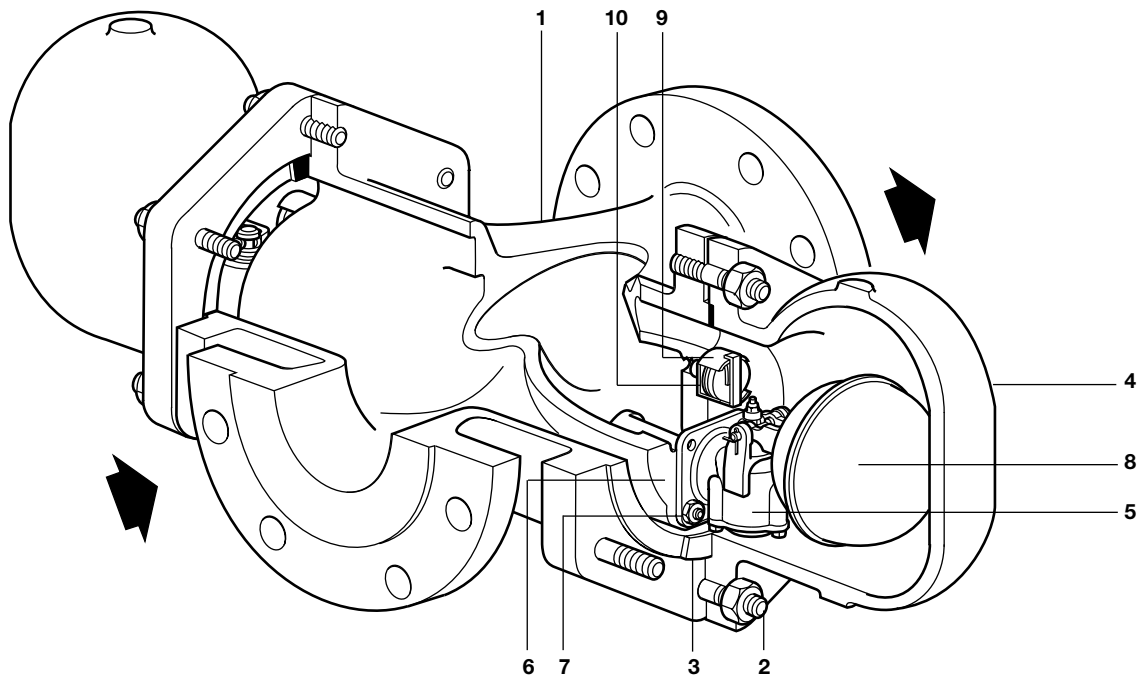

### Description

The FT43 is a cast iron bodied ball float steam trap having stainless steel working internals and automatic air venting facility. It is available with horizontal flanged connections only. If required, the covers can be drilled and tapped 2" BSP or NPT for the purpose of fitting drain cocks.

### Standards

This product fully complies with the requirements of the European Pressure Equipment Directive 97/23/EC and carries the CE mark when so required.

### Certification

This product is available with a manufacturer's Typical Test Report.  
**Note:** All certification/inspection requirements must be specified at the time of order placement.

### Materials

No.	Part	Material	
1	Body	Cast iron	DIN 1691 GG 20
2	Cover studs and nuts	Steel	BS 4439 Gr. 8.8 BS 3692 Gr. 8
3	Cover gasket	Reinforced exfoliated graphite	
4	Cover	Cast iron	EN JL 1040
5	Main valve assembly	Stainless steel	BS 3146 Pt. 2 ANC 2
6	Main valve assembly gasket	Reinforced exfoliated graphite	
7	Main valve assembly studs and nuts	Stainless steel	BS 6105 A4-80
8	Ball float and lever	Stainless steel	BS 1449 304 S16
9	Air vent assembly	Stainless steel	
10	Air vent seat gasket	Stainless steel	BS 1449 409 S19

### Pressure/temperature limits (ISO 6552)

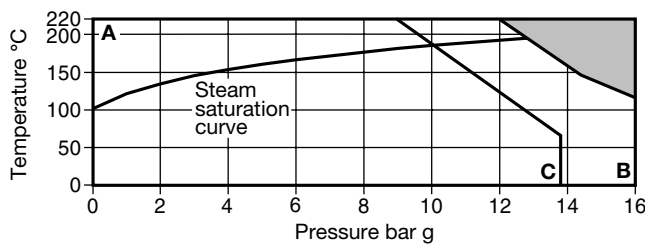

The product **must not** be used in this region.

A - B Flanged EN 1092 PN16.

A - C Flanged ASME (ANSI) 125 and JIS / KS 10.

Body design conditions		PN16
PMA	Maximum allowable pressure	16 bar g @ 120°C
TMA	Maximum allowable temperature	220°C @ 12.1 bar g
Minimum allowable temperature		0°C
PMO	Maximum operating pressure for saturated steam service	limited to ΔPMX
TMO	Maximum operating temperature	220°C @ 12.1 bar g
Minimum operating temperature		0°C
<b>Note:</b> For lower operating temperatures consult Spirax Sarco		
		<b>FT43-4.5</b> 4.5 bar
ΔPMX	Maximum different pressure	<b>FT43-10</b> 10 bar
		<b>FT43-14</b> 13 bar
Designed for a maximum cold hydraulic test pressure of 24 bar g		

Local regulations may restrict the use of this product to below the conditions quoted.

In the interests of development and improvement of the product, we reserve the right to change the specification without notice.

© Copyright 2010

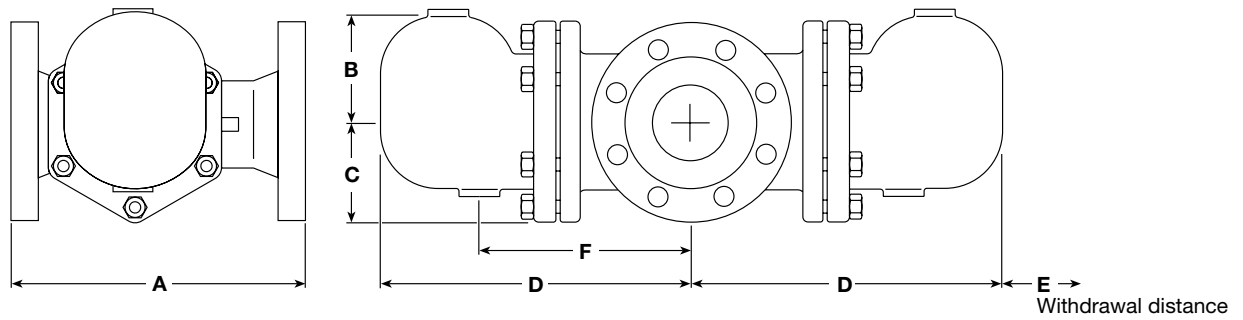

### Capacities - DN80 and DN100

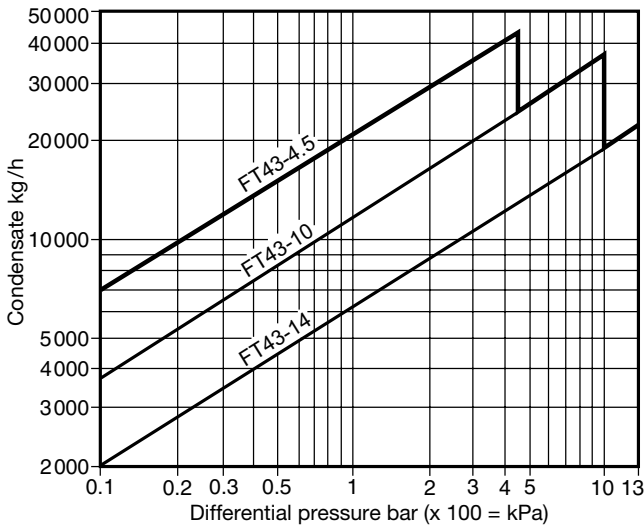

**Additional cold water capacities from the thermostatic air vent under start-up conditions**  
 Capacities shown above are based on condensate at saturation temperature. Under start-up conditions when the condensate is cold the internal thermostatic air vent will be open and provides additional capacity to the main valve. The following table gives the minimum additional cold water capacities from the air vent.

$\Delta p$ (bar)	0.5	1	2	3	4.5	7	10	13
<b>Size</b>	<b>Minimum additional cold water capacity (kg/h)</b>							
<b>DN80</b>	1 080	1 200	1 240	1 340	1 400	2 000	2 600	3 200
<b>DN100</b>	1 080	1 200	1 240	1 340	1 400	2 000	2 600	3 200

### Dimensions / weights (approximate) in mm and kg

Size	JIS/KS								Weight
	PN16		10		ASME		E	F	
	A	A	A	B	C	D			
DN80	352	-	343	140	123	387	200	310	72
DN100	350	350	350	140	123	387	200	310	74

### Safety information and maintenance

For full details see the Installation and Maintenance Instructions (IM-S02-30) supplied with the product.

**Installation note:** The FT43 must be installed with the direction of flow as indicated on the body, and with the float arm in a horizontal plane so that it rises and falls vertically.

**Disposal:** This product is recyclable. Providing due care is taken no ecological hazard is anticipated with its disposal.

### How to order

**Example:** 1 off Spirax Sarco CDN100 FT43-4.5 ball float steam trap flanged to EN 1092 PN16, with cast iron body and cover with thermostatic air vent.

### Spare parts

The spare parts available are shown in heavy outline. Parts drawn in broken line are not supplied as spares.

#### Available spares

Main valve assembly	5, 6, 7
Ball float and lever	8
Air vent assembly	9, 10
Set of gaskets	3, 6, 10

**Note:** For a complete overhaul 2 x each spare is required, with the exception of the gaskets and main valve assembly kit.



#### How to order spares

Always order spares by using the description given in the column headed 'Available spares' and state the size and type of trap.

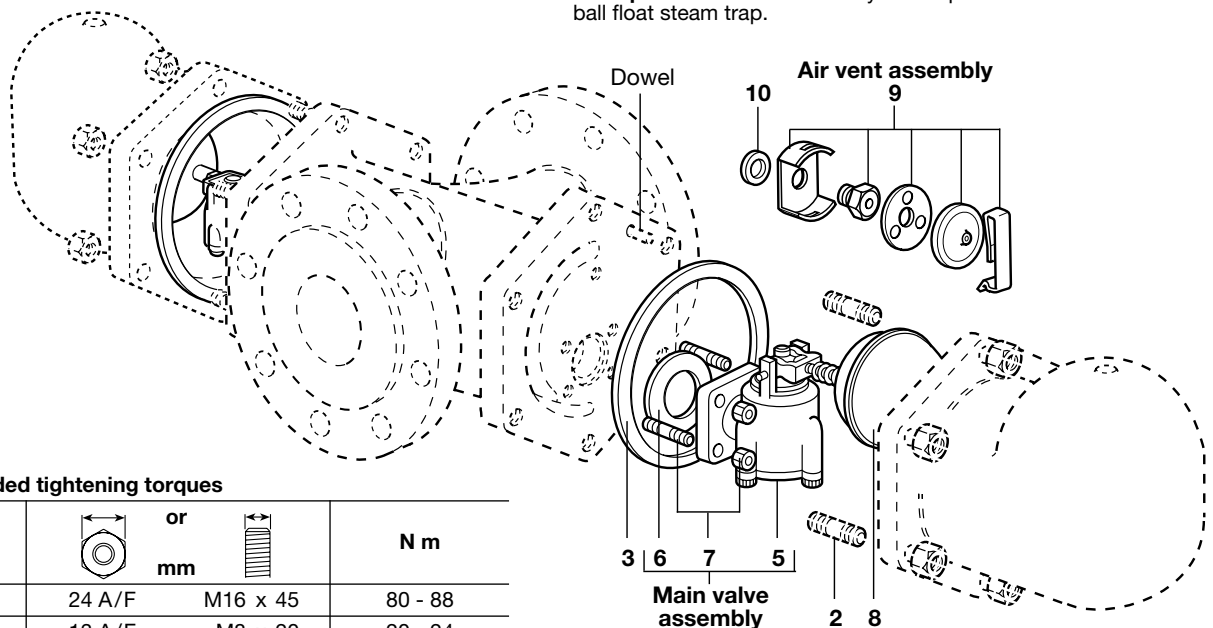
**Example:** 1 - Air vent assembly for a Spirax Sarco DN80 FT43-45 ball float steam trap.



### Recommended tightening torques

Item	 or 	mm	N m
2	24 A/F	M16 x 45	80 - 88
7	13 A/F	M8 x 20	20 - 24
9	17 A/F		50 - 55