



Cert. No. LRQ 0963008

ISO 9001

spirax sarco

FT43

Cast Iron

Ball Float Steam Trap DN25 to DN50

Description

The FT43 is a cast iron bodied ball float steam trap having stainless steel working internals and automatic air venting facility. The trap is supplied with integrally flanged connections and can be maintained without disturbing the pipework. Vertical flanged connections, designated FT44V, are available for all sizes. Flow direction for the horizontal trap is clearly illustrated below. For vertically orientated traps the flow is downwards only.

Available options: **FT43** – Horizontal flow **FT43V** – Vertical flow

Capsule

The BP99/32 capsule which is used in the FT43 is suitable for use on 150°C superheat @ 0 bar g and 50°C superheat @ 32 bar g.

Standards

This product fully complies with the requirements of the European Pressure Equipment Directive 97/23/EC and carries the **CE** mark when so required.

Certification

This product is available with a manufacturers' Typical Test Report. **Note:** All certification/inspection requirements must be stated at the time of order placement.

Optional extras

A **manually adjustable needle valve** (designated 'C' on the nomenclature i.e. FT43-C) can be fitted to the FT43. This option provides a **steam lock release (SLR)** feature in addition to the standard air vent. For further information please consult Spirax Sarco.

The **top of the cover can be drilled and tapped 3/8" BSP or NPT** for the purpose of fitting a balance line if requested at the point of order.

The **bottom of the cover can be drilled and tapped 3/8" BSP or NPT** for the purpose of fitting a drain cock if requested at the point of order.

Pressure / temperature limits

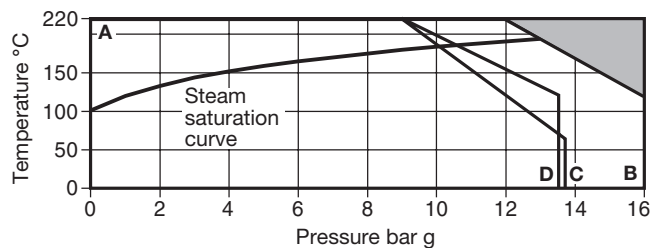

The product **must not** be used in this region.

- A - B Flanged EN 1092 PN16.
- A - C Flanged ANSI 125.
- A - D Flanged JIS/KS 10 (DN25 only).

Body design conditions		PN16
PMA	Maximum allowable pressure	16 bar g @ 120°C
TMA	Maximum allowable temperature	220°C @ 12.1 bar g
Minimum allowable temperature		0°C
PMO	Maximum operating pressure for saturated steam service	13 bar g @ 195°C
Note: The DN40 and DN50 traps are limited to a PMO equal to PMX		
TMO	Maximum operating temperature	220°C @ 12.1 bar g
Minimum operating temperature		0°C
Note: For lower operating temperatures consult Spirax Sarco		
	FT43-4.5	4.5 bar
ΔPMX	Maximum differential pressure	FT43-10 10 bar
	FT43-14	13 bar

Designed for a maximum cold hydraulic test pressure of 24 bar g

Note: With internals fitted, test pressure must not exceed ΔPMX

FT43
DN25

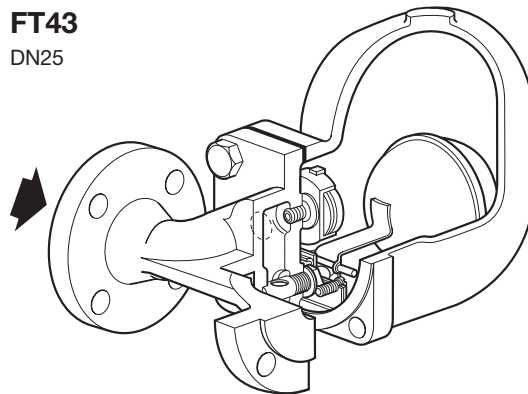

FT43-C

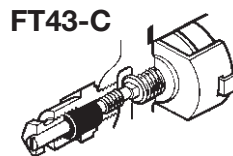

FT43
DN40 and DN50

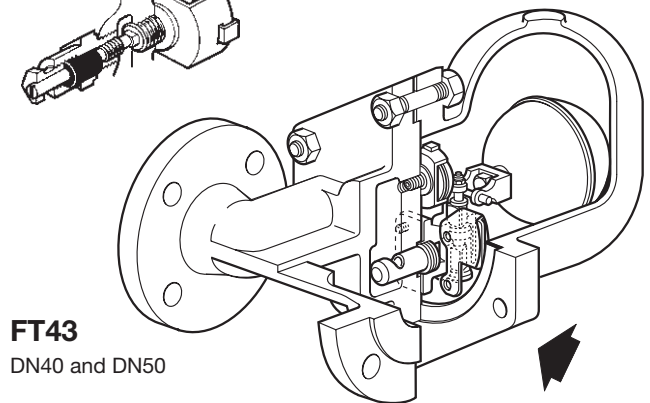

Sizes and pipe connections

DN25, DN40 and DN50

Note: Flow direction, for FT43 horizontal orientated traps, when facing the body: - DN25 is left to right. - DN40 and DN50 is right to left. Flow direction, for FT43V vertically orientated traps is downwards only.

Standard flanges are EN 1092 PN16 with face-to-face dimensions in accordance with EN 26554 (Series 1).

On request - ANSI B 16.5 Class 125 and JIS/KS 10 flanges are also available.

Note: ANSI and JIS/KS flanges are supplied with tapped holes to receive flange bolts. ANSI flanges have UNC threads and JIS/KS have metric threads.

FT43
DN25

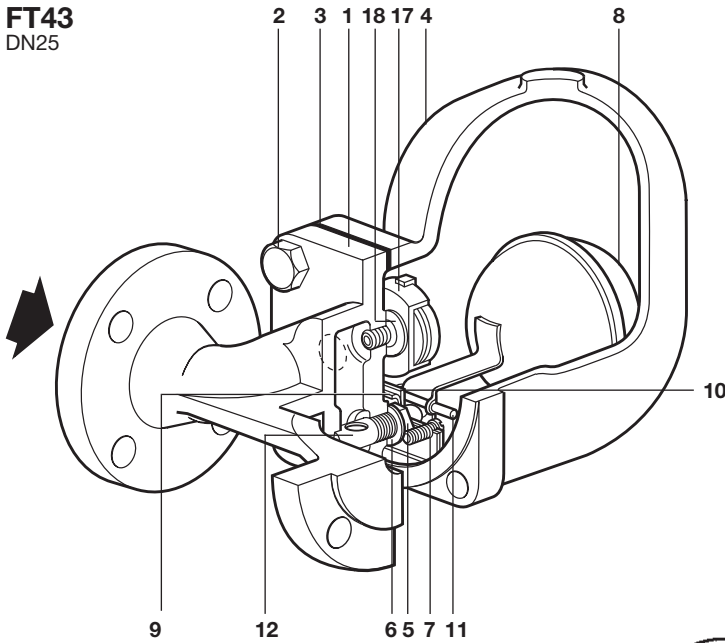

FT43-C

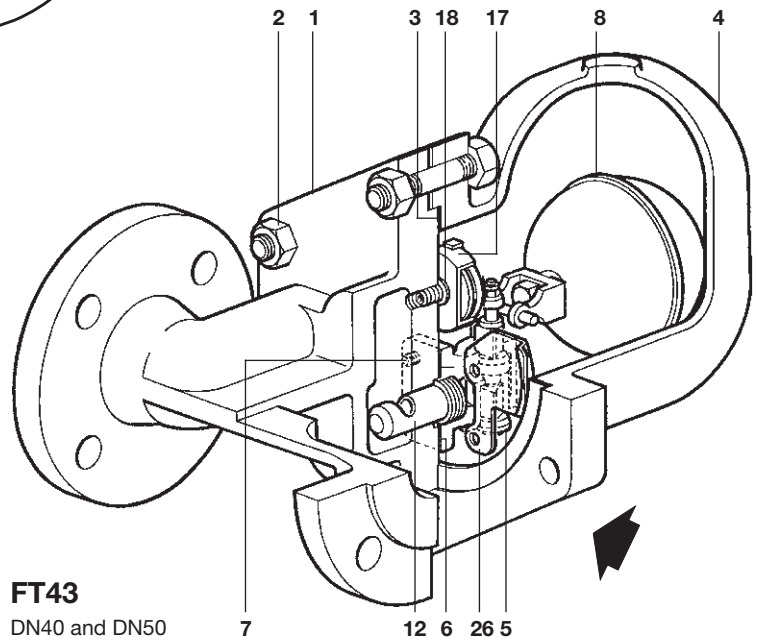
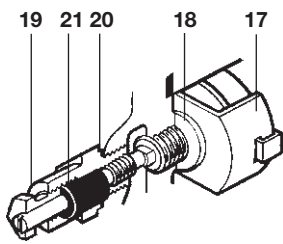

FT43
DN40 and DN50

Materials

No.	Part	Material	
1	Body	Cast iron	EN-JL 1040
	Cover bolts	DN25	Steel BS 3692 Gr. 8.8
2	Cover stud	Steel	BS 4882 - B7M
	Cover nuts	Steel	BS 3692 Gr. 8.8
3	Cover gasket	Reinforced exfoliated graphite	
4	Cover	Cast iron	EN-JL 1040
	Valve seat	DN25	Stainless steel BS 970 431 S29
5	Main valve assembly with erosion deflector	DN40, DN50	Stainless steel BS 3146 Part 2 Anc 2
	Valve seat gasket	DN25	Stainless steel BS 1449 304 S11
6	Main valve assembly gasket	DN40, DN50	Reinforced exfoliated graphite
	Pivot frame assembly bolts	DN25	Stainless steel BS 4183 18/8
7	Main valve assembly bolts	DN40	Stainless steel BS 970 304 S16
	Studs and nuts	DN50	Stainless steel BS 6105 A4.80
8	Ball float and lever	Stainless steel	BS 1449 304 S16
9	Support frame	Stainless steel	BS 1449 304 S16
10	Pivot frame	Stainless steel	BS 1449 304 S16
11	Pivot pin	Stainless steel	
12	Erosion deflector	Stainless steel	BS 970 431 S29
17	Air vent assembly	Stainless steel	
18	Air vent seat gasket	Stainless steel	BS 1449 409 S19
19	SLR assembly	Stainless steel	BS 970 303 S21
20	SLR gasket	Mild steel	BS 1449 CS4
21	SLR seal	Graphite	
26	Inlet plate	DN40, DN50	Stainless steel BS 1449 304 S15

Capacities

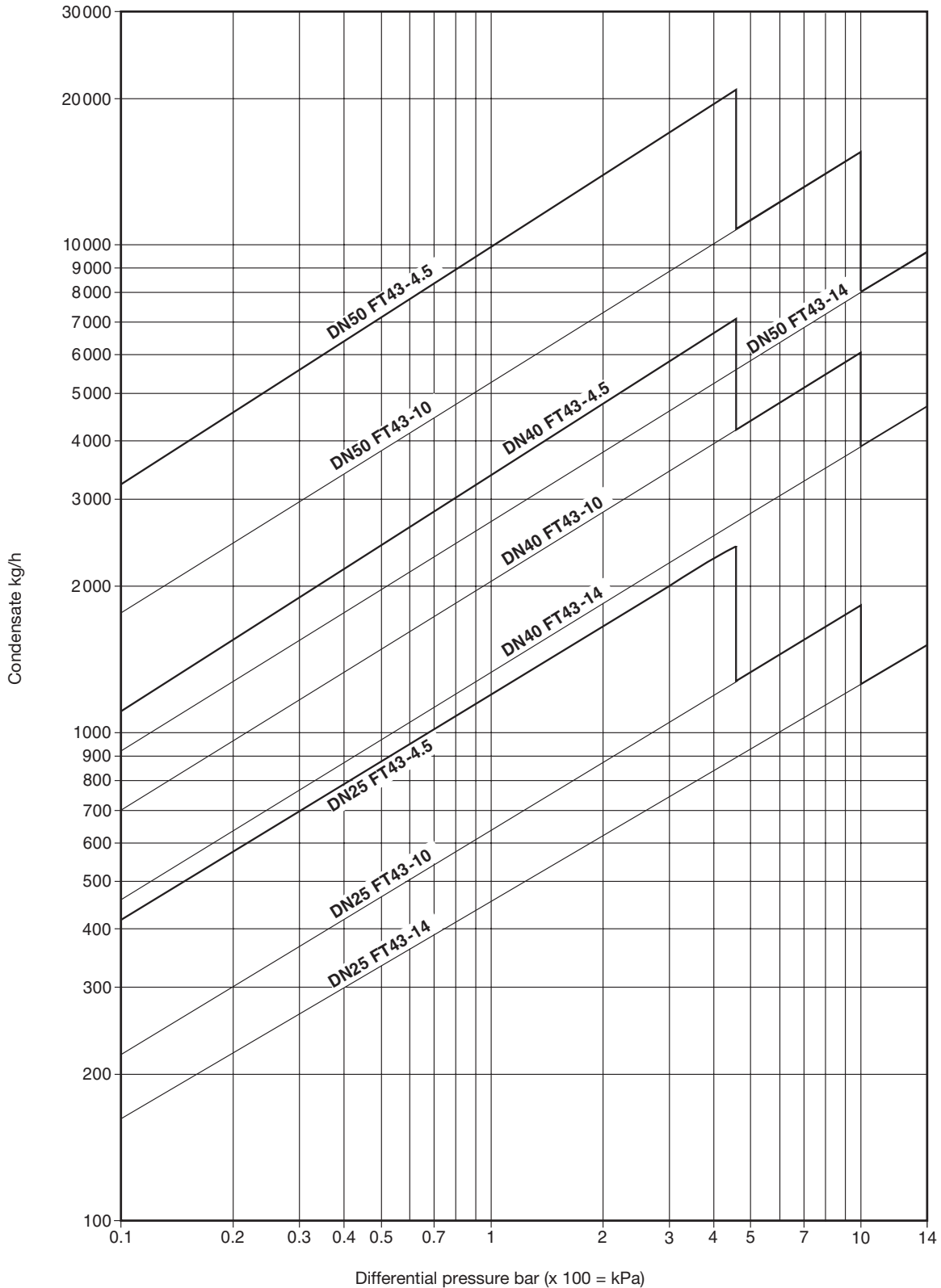

Additional cold water capacities from the thermostatic air vent under start-up conditions

Capacities shown above are based on condensate at saturation temperature. Under start-up conditions when the condensate is cold the internal thermostatic air vent will be open and provides additional capacity to the main valve. The following table gives the minimum additional cold water capacities from the air vent.

ΔP (bar)	0.5	1	2	3	4.5	7	10	14
	Minimum additional cold water capacity (kg/h)							
DN25, DN40 and DN50	460	680	900	1 080	1 300	1 600	1 980	2 050

FT43

DN40 and DN50 shown

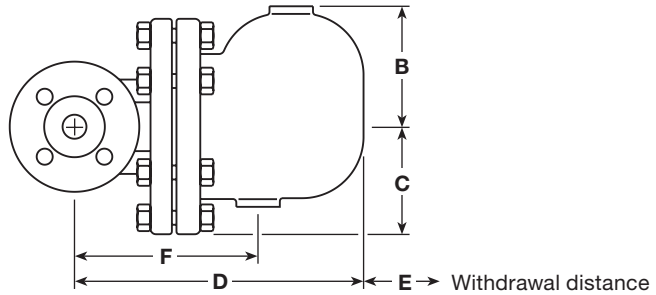
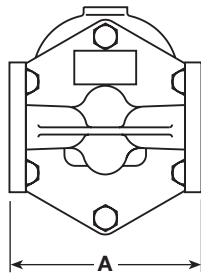

Dimensions/weights (approximate) in mm and kg

Size	A		B	C	D	E	F	Weight
	PN16	ANSI 125						
DN25	160	148	110	80	245	160	215	8.3
DN40	230	221	128	110	330	200	200	21.5
DN50	230	220	140	126	340	200	225	30.5

For PN16 the face-to-face dimensions are in accordance with ISO 6554. For dimensions of other flange variants, please contact Spirax Sarco.

Safety information, installation and maintenance

For full details see the Installation and Maintenance Instructions (IM-S02-30) supplied with the product.

Installation note:

The FT43 must be installed with the direction of flow as indicated on the body, and with the float arm in a horizontal plane so that it rises and falls vertically.

Disposal

This product is recyclable. No ecological hazard is anticipated with the disposal of this product providing due care is taken.

How to order

Example: 1 off Spirax Sarco DN25 FT43-4.5 ball float steam trap, flanged to EN 1092 PN16 with cast iron body and cover with thermostatic air vent.

Spare parts

The spare parts available are shown in solid outline. Parts drawn in broken line are not supplied as spares.

Available spares

Main valve assembly with float (DN25 horizontal traps)*	5, 6, 7, 8, 9, 10, 11
Main valve assembly with erosion deflector (DN40 and DN50) ** (specify horizontal or vertical trap)	5, 6, 7, 12, 26
Ball float and lever (DN40 and DN50)	8
Air vent assembly	17, 18
Manually adjustable needle valve and air vent assembly	17, 18, 19, 20, 21
Complete set of gaskets (packet of 3)	3, 6, 20

* On horizontal traps the erosion deflector on the DN25 is pressed into the body during manufacture and not available as a spare.

** There is no erosion deflector on vertical traps.



How to order spares

Always order spares by using the description given in the column headed 'Available spares' and state the size and type of trap, including pressure range and orientation i.e. horizontal or vertical connections.

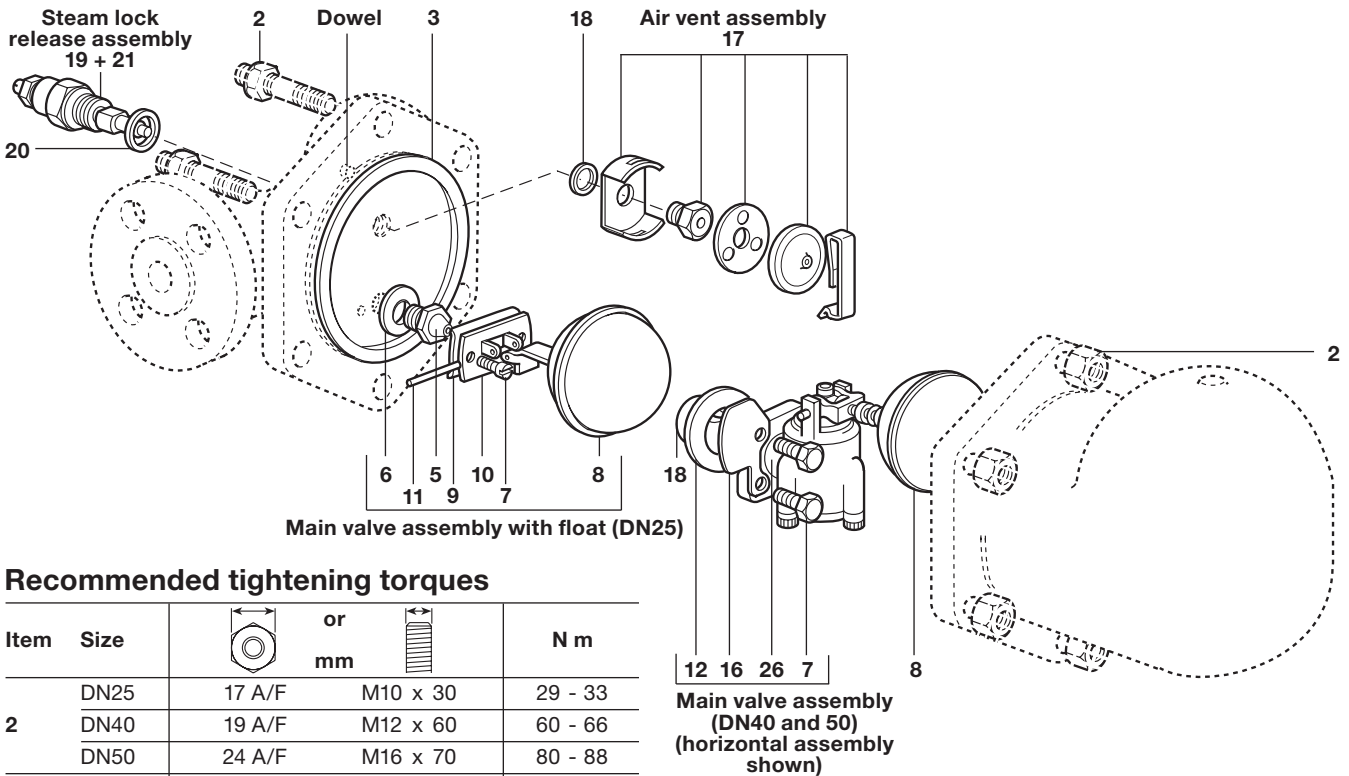
Example: 1 - Air vent assembly for a Spirax Sarco DN25 FT43-4.5 ball float steam trap, with horizontal connections.



Recommended tightening torques

Item	Size	or		N m
				
2	DN25	17 A/F	M10 x 30	29 - 33
	DN40	19 A/F	M12 x 60	60 - 66
	DN50	24 A/F	M16 x 70	80 - 88
5	DN25			50 - 50
	DN25		M5 x 20	2.5 - 2.8
7	DN40	10 A/F	M6 x 20	10 - 12
	DN50	13 A/F	M8 x 20	20 - 24
17		17 A/F		50 - 55
19		22 A/F		50 - 55